

Direct Mount,
Two Piece Flanged Ball Valve

CLASS 150 & 300 1/2" -4"

2500
Series



OVERVIEW

STANDARDS

Design	ASME B16.34
Flange Design	ASME B16.5
Face-to-Face	ASME B16.10
Testing	API 598
Inspection	MSS SP-55
Marking	MSS SP-25
Mounting	ISO 5211
Quality Assurance	ISO 9001:2015

APPROVALS & CERTIFICATIONS

Canadian Registration Number	CRN Registered
Gas/Flammable Liquid Shutoff	UL Certified
Fire Safe	API 607-7th Edition
Sulfide Stress Cracking	NACE MR0175
Reliability	SIL Rated IEC 61508:2010
Fugitive Emissions	TA LUFT
Hazardous Areas	ATEX 2014/34/EU
Design/Manufacture	CE/PED 2014/68/EU

FEATURES & BENEFITS

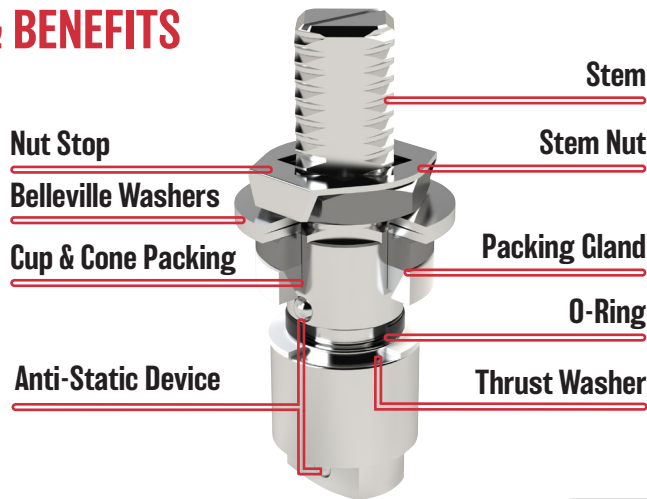

4 Stem Packing

The stem packing is live loaded with Belleville washers and incorporates a cup and cone packing design along with antistatic devices. The packing ensures consistent sealing, minimizes maintenance, and enhances safety by preventing static discharge.

5 Direct Mounting

The integrally cast, ISO 5211 compliant mount on both class 150 and 300 valves provides a safe, secure mounting surface for actuators. This design promotes ease and versatility in installation.

3 Seat

Utilizing precision manufacturing techniques and advanced materials such as TFM1600 and PTFE, the seat provides a bubble tight sealing surface between the ball and body, while keeping operating torques low.

6 Handle

The handle includes a locking device for secure lockout/tagout procedures and features a rubber coating for enhanced comfort during operation.

2 Body/Endcap

The body and endcap are designed to ASME B16.34 standards, which house all internal components and are investment cast and inspected to MSS SP-55. JFlow's 2500 series features integrated class 150 flanges, ensuring standard face-to-face dimensions in compliance with ASME B16.10.

1 Ball

Balls are crafted from high-quality metal that is forged, precision machined, heat treated, lapped and polished using advanced manufacturing techniques. This process guarantees a bubble tight shutoff and low operating torque.

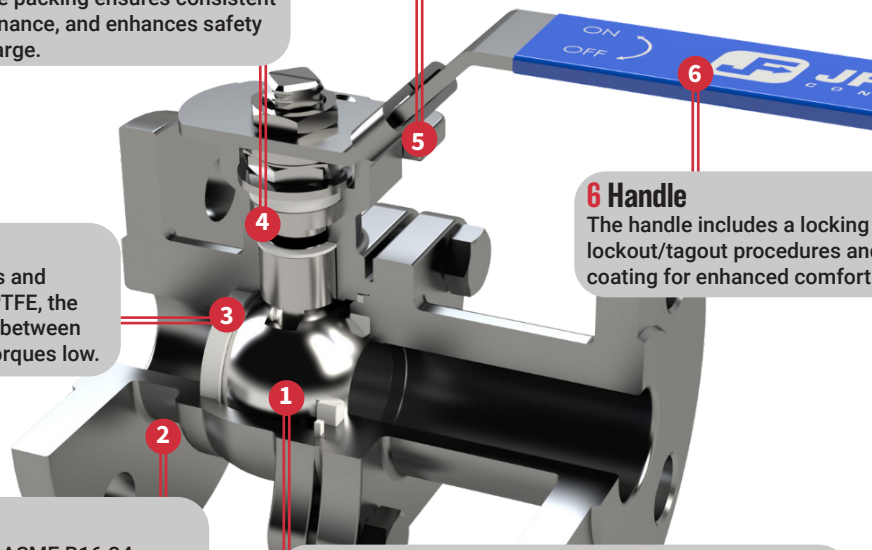

DIMENSIONS

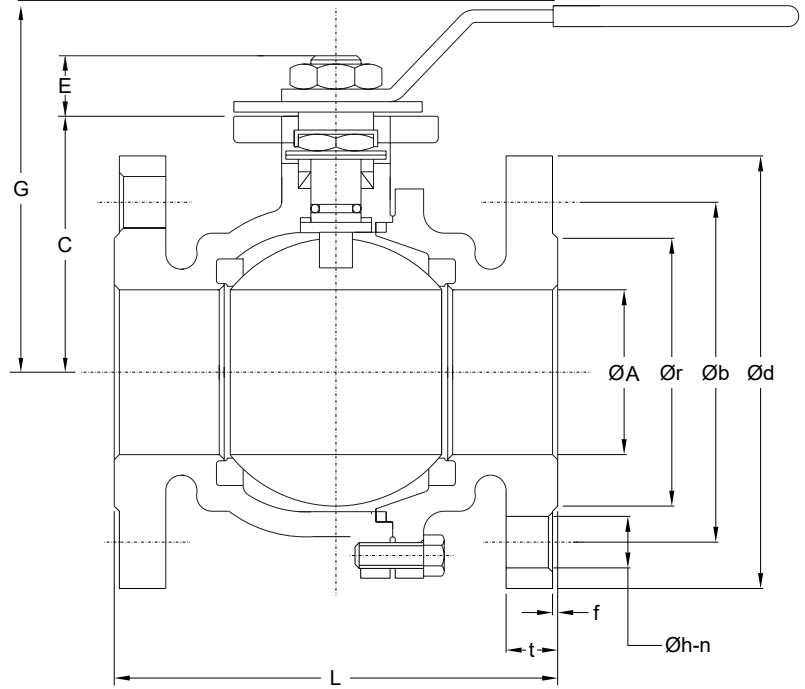
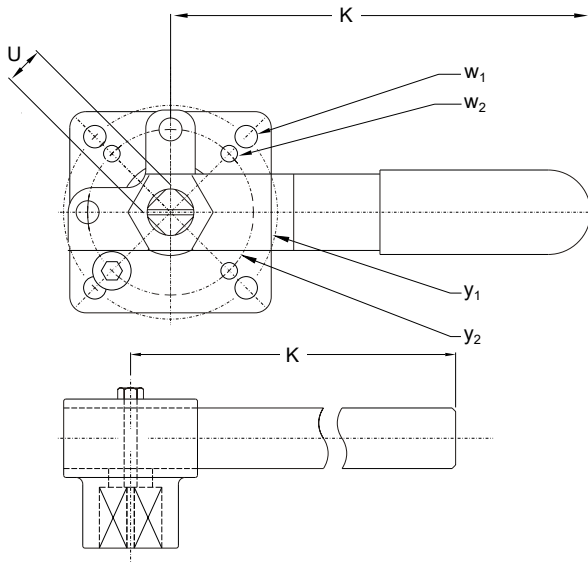

CLASS 150 & CLASS 300 MOUNTING

NPS	U	w1	w2	y1	y2	ISO
1/2	0.354 (9MM)	0.236	0.236	1.65	1.42	F03/F04
3/4	0.354 (9MM)	0.236	0.236	1.65	1.42	F03/F04
1	0.433 (11MM)	0.276	0.236	1.97	1.65	F04/F05
1-1/4	0.433 (11MM)	0.276	0.236	1.97	1.65	F04/F05
1-1/2	0.551 (14MM)	0.362	0.276	2.76	1.97	F05/F07
2	0.551 (14MM)	0.362	0.276	2.76	1.97	F05/F07
2-1/2	0.669 (17MM)	0.449	0.362	4.02	2.76	F07/F10
3	0.669 (17MM)	0.449	0.362	4.02	2.76	F07/F10
4	0.866 (22MM)	0.531	0.449	4.92	4.02	F10/F12

CLASS 150 GENERAL

FLANGE

NPS	ØA	C	E	G	L	K	Ør	Øb	Ød	t	f	Øh-n	Weight(lbs)	Cv*
1/2	0.59	1.89	0.43	3.15	4.25	5.12	1.38	2.38	3.50	0.45	0.063	0.63-4	3.8	21
3/4	0.79	2.09	0.43	3.15	4.61	5.12	1.69	2.76	3.86	0.45	0.063	0.63-4	4.7	50
1	0.98	2.32	0.55	3.54	5.00	6.50	2.01	3.13	4.25	0.45	0.063	0.63-4	6.4	90
1-1/4	1.26	2.80	0.55	4.02	5.51	6.50	2.52	3.50	4.61	0.50	0.063	0.63-4	8.9	110
1-1/2	1.50	2.99	0.71	4.33	6.50	8.07	2.87	3.88	5.00	0.56	0.063	0.63-4	13.0	240
2	1.97	3.35	0.71	4.72	7.01	8.07	3.62	4.74	5.98	0.63	0.063	0.75-4	19.2	400
2-1/2	2.56	3.68	0.91	5.51	7.48	11.81	4.13	5.49	7.01	0.70	0.063	0.75-4	29.4	700
3	3.15	4.06	0.91	5.91	7.99	13.39	5.00	6.00	7.48	0.75	0.063	0.75-4	37.6	980
4	3.94	5.20	0.98	7.09	9.02	16.54	6.18	7.50	9.02	0.94	0.063	0.75-4	63.9	1700

CLASS 300 GENERAL

FLANGE

NPS	ØA	C	E	G	L	K	Ør	Øb	Ød	t	f	Øh-n	Weight(lbs)	Cv*
1/2	0.59	2.01	0.47	3.19	5.51	5.12	1.38	2.62	3.74	0.57	0.063	0.63-4	4.7	21
3/4	0.79	2.40	0.45	3.58	5.98	5.12	1.69	3.25	4.61	0.63	0.063	0.75-4	7.1	50
1	0.98	2.56	0.55	3.74	6.50	6.50	2.01	3.50	4.88	0.69	0.063	0.75-4	9.6	90
1-1/4	1.26	2.80	0.51	3.98	7.01	6.50	2.52	3.88	5.28	0.77	0.063	0.75-4	14.5	110
1-1/2	1.50	3.13	0.63	4.72	7.48	8.07	2.87	4.51	6.14	0.83	0.063	0.87-4	19.4	240
2	1.97	3.35	0.63	4.92	8.50	8.07	3.62	5.00	6.50	0.89	0.063	0.79-8	25.2	400
2-1/2	2.56	3.82	0.71	5.98	9.49	12.20	4.13	5.87	7.48	1.00	0.063	0.87-8	37.7	700
3	3.15	4.31	0.71	6.50	11.14	12.20	5.00	6.61	8.27	1.14	0.063	0.87-8	51.2	980
4	3.94	5.31	0.98	7.80	12.01	12.20	6.18	7.87	10.00	1.26	0.063	0.87-8	72.8	1700

*Cv is defined as the number of US gallons of water at 60F that will flow through a valve, per minute, with a pressure drop of 1psi across the valve

STANDARD MATERIAL LIST - 2500 SERIES

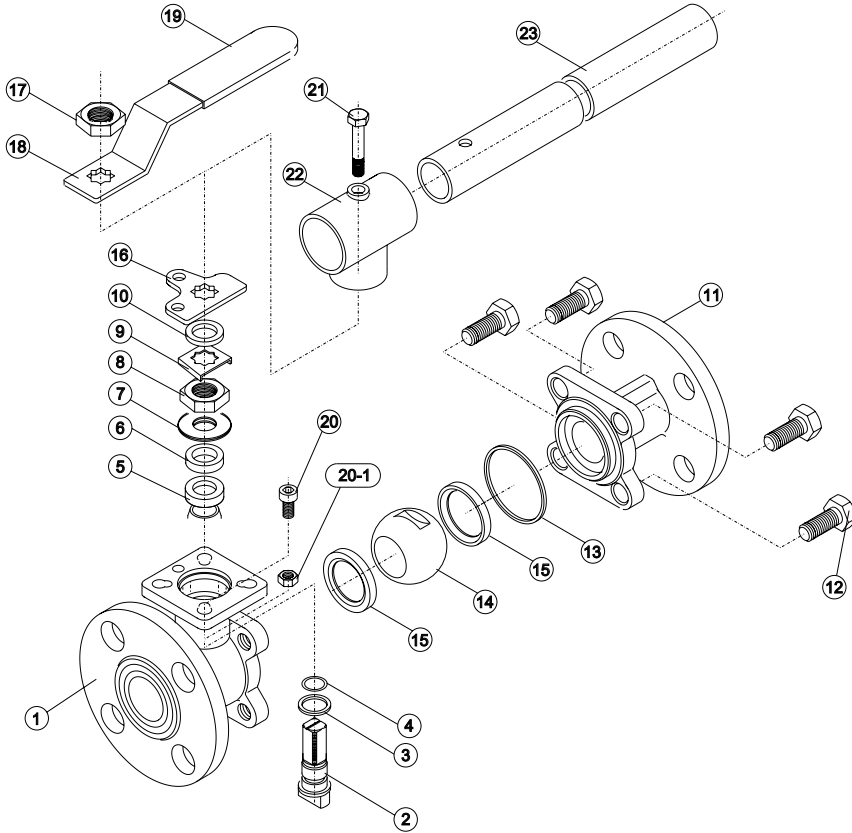

Part	Name	Stainless Steel	Carbon Steel
1	Body	ASTM A351 Gr CF8M	ASTM A216 Gr WCB
2	Stem	ASTM A479 Type 316	
3	Thrust Washer		RPTFE
4	O-ring		VITON
5	Stem Packing		PTFE
6	Gland		SS 304
7	Disk Washer		SS 301
8	Stem Nut		SS 304
9	Nut Stop		SS 304
10	Washer		SS 304
11	Flanged End	ASTM A351 Gr CF8M	ASTM A216 Gr WCB
12	Bolt		SS304
13	Gasket		PTFE
14	Ball	SS 316	SS 304
15	Seat	PTFE	RPTFE
16	Stop Plate		SS 304
17	Handle Nut		SS 304
18	Handle		SS 304
19	Sleeve		Vinyl
20	Stop Pin		SS304
21	Set Bolt		CF8
22	Lever Head	ASTM A351 Gr CF8	
23	Pipe Handle	Steel Pipe	

*JFlow Controls offers a standard repair kit that includes all recommended spare parts: seats, body seal, stem packing, and O-ring.

TORQUE (in-lb) - CLASS 150 & 300

NPS\PSI	0	100	200	300	400	500	600	700	800	900	1000
1/2	62	62	62	62	62	62	62	71	71	71	71
3/4	80	80	80	80	80	80	80	80	89	89	106
1	106	106	106	106	106	106	106	115	115	124	124
1-1/4	103	133	133	133	133	133	150	150	159	168	186
1-1/2	266	266	266	266	274	283	292	310	319	345	363
2	354	354	354	354	363	363	363	407	460	513	566
2-1/2	664	770	770	867	929	1027	1133	1230	1337	-	-
3	867	867	929	929	974	1230	1381	1434	1540	-	-
4	974	1027	1221	1540	2151	2611	2912	3036	3169	-	-

*20% safety factor included

PRESSURE/TEMPERATURE

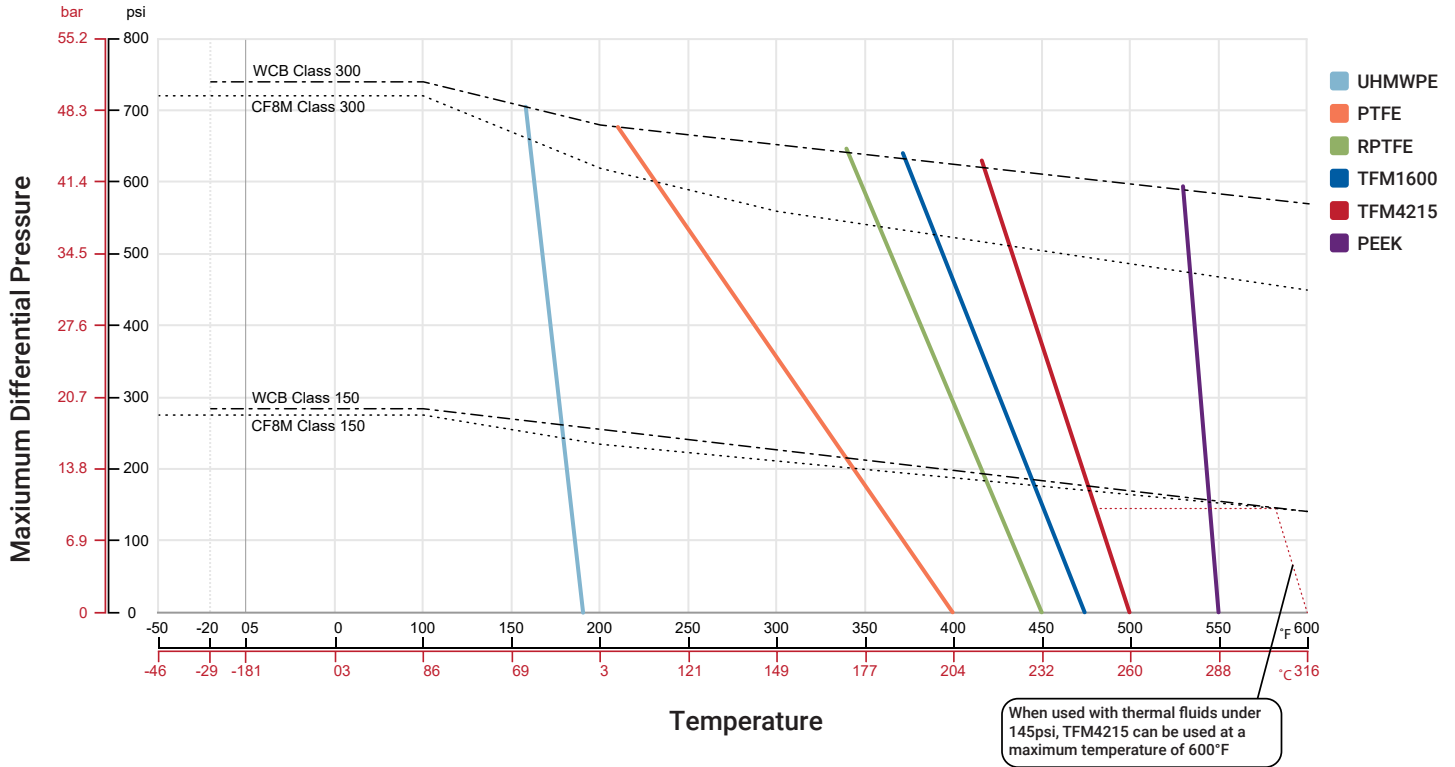

BODY & END CAP ASME B16.34 RATINGS

Temperature (°F)	Class 150 (psi)		Class 300 (psi)	
	CF8M	WCB	CF8M	WCB
-20 to 100	275	285	720	740
200	235	260	620	680
300	215	230	560	655
400	195	200	515	635
500	170	170	480	605
600	140	140	450	570

SOFT GOODS TEMPERATURE RATINGS

Component	Material	Temperature (°F)
Stem Packing	TFM-1600	-75 to 475
Body Seal	TFM-1600	-75 to 475
O-Ring	FKM (Standard)	-15 to 400
	Kalrez	-2 to 600
	BUNA-N	-31 to 248
	Silicone	-60 to 450
	EPDM	-60 to 300

JFlow Controls 2500 Series 2 piece flanged ball valve is offered in several different body and trim materials in order to accommodate a variety of different industrial applications.

* CF8M can reach temperatures as low as -50°F

V-Ball Options

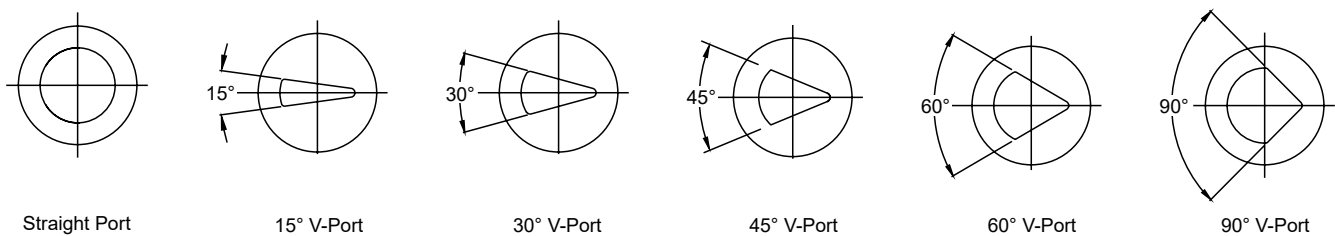

*Contact JFlow Controls for specific Cv values on V-Port balls

HOW TO ORDER - 2500



Size	Series	Body Ball Stem	Port	Packing	Seat	Body Seal	End Connection	Operator/ Bracket
3 - 1/2"								
4 - 3/4"								
5 - 1"								
0 - 1-1/4"								
6 - 1-1/2"								
7 - 2"								
8 - 2-1/2"								
9 - 3"								
A - 4"								
F - API 607 FIRESAFE CERTIFIED								
25 - 2500 2PC FLANGED (DIRECT MOUNT)								
	BODY	BALL	STEM					
23 -	WCB	316S	316S					
33 -	CF8M	316S	316S					
*								
F -	FULL PORT		6 -	60 DEGREE V-BALL				
R -	REDUCED PORT		9 -	90 DEGREE V-BALL				
1 -	15 DEGREE V-BALL		S -	1/16" SLOT				
3 -	30 DEGREE V-BALL		8 -	1/8" SLOT				
4 -	45 DEGREE V-BALL							
T -	TFM1600		G -	GRAPHITE				
C -	TFM4215		U -	UHMWPE				
T -	TFM1600		P -	PEEK				
C -	TFM4215		U -	UHMWPE				
T -	TFM1600		G -	GRAPHITE				
C -	TFM4215		U -	UHMWPE				
F1 -	ANSI CLASS 150 RF FLANGE							
F3 -	ANSI CLASS 300 RF FLANGE							
LD -	LOCKING LEVER HANDLE		SE -	STEM EXTENSION (CONTACT JFLOW SALES FOR DIFFERENT HEIGHTS)				
OH -	OVAL HANDLE		LB -	LOCKOUT BRACKET				
SH -	SPRING RETURN HANDLE		BS -	BARE STEM				
GO -	MANUAL GEAR OPERATOR		*					

*Contact JFlow Controls for additional material options and automation capabilities



The Right Valve - The Right Application - Right Now!

4665 Interstate Drive, Cincinnati, OH 45246 USA
P- 513-731-2900 F- 513-731-6939
sales@jflowcontrols.com JFLOWCONTROLS.COM



While the information and specifications contained in this literature are believed to be accurate, they are supplied for informative purposes only and should not be considered certified or a guarantee of satisfactory results. Nothing contained herein is to be construed as a warranty or guarantee, express or implied, regarding any matter with respect to this product. JFlow Controls® is continually improving and upgrading its product design, therefore the specifications, dimensions and information contained herein are subject to change without notice.