



STANDARDS

- ASME / ANSI B16.10
- Wall thickness complies to B16.34
- Designed to ASME / ANSI B16.5, B16.10, B16.34, B31.1, B31.4 and B41.8 standards
- NACE MR 0175 compliance

J Flow Controls 9800 Series Metal to Metal Trunnion Ball Valves

FEATURES & BENEFITS

- A single seat ball valve has a flat spring set acting through a hard face bearing against the bottom ball shaft which provides sufficient initial ball-seat load for valve tightness, even at low psi
- Design provides freedom for thermal expansion of the ball without jamming even at high temperatures
- Tightness rate allowable leakage rate at full psi, ASME / FC1702 Class V with special lapping, tighter shutoff available upon request
- All metal seated trunnion valves come standard with grease fittings
- Double block and bleed

APPLICATIONS & INDUSTRIES

- Petro-chemical
- Oil refining
- Iron ore processing
- Filter skids
- Sulfur removal
- Power
- Metallurgy
- Light industries
- High temperature
- Solid articles
- Ash dregs

DESCRIPTION

The seat material of general purpose ball valves employ generally non-metal material, such as PTFE. Limited by the seat material, the general purpose ball valve cannot be used in case of high temperature applications and applications with solid articles and ash dregs. So the application scope of general purpose ball valves is restricted partially. Taking this into consideration, we offer a full range of metal to metal seated ball valves, including floating ball valves and trunnion ball valves, which are found in extensive applications such as petroleum, chemistry, power, metallurgy and light industries.

DESIGN FEATURES OF TRUNNION BALL VALVE

Metal to metal sealed design has been employed perfectly for the ball and seat, which has also adopted the advanced hardening technologies, such as ultrasonic spray coating, nickel base spray welding, surface specially hardening, satellite spray welding, ceramic material with high strength, and hardness, etc. Surface hardness of the ball and seat may generally reach more than HRC60, maximum up to HRC74, and application temperature of the material may be up to 1004°F, maximum up to 1976°. Combining strength of the material gets to more than 1000 psi. Besides, the surface material possesses very good resistance properties of friction and impact. Metal to metal sealed ball valves are suitable for use in most critical working conditions.



ultra-sonic spray coating for ball and seat

HIGH TEMPERATURE WORKING CONDITIONS

In the case of high temperature working conditions, the valve seat and ball would easily get stuck due to heat expansion, and the valve could not be opened. Metal to metal sealed ball valves employ the patented design of bellville spring loading, which would absorb the heat expansion of parts caused by the bellville spring. So, it is ensured that the valve would not get stuck and could open and close easily in the case of high temperature conditions.

FEATURES & BENEFITS



- ASME / ANSI B16.10
- NACE MR 0175 compliance
- Wall thickness complies with B16.34
- J-Flow's single seat ball valve has a flat spring set acting through a hard face bearing against the bottom ball shaft which provides sufficient initial ball-seat load for valve
- J-Flow's design provides freedom for thermal expansion of the ball without jamming even at high temperatures
- Tightness rate allowable leakage rate at full psi, ASME / FC170-2 Class V with special lapping, tighter shutoff available upon request
- Typical applications can be found in the petro-chemical, oil refining, iron ore processing, filter skids, and sulfur removal
- Designed to ASME / ANSI B16.5, B16.10, B16.34, B31.1, B31.4 and B31.8 standards
- All metal seated trunnion valves come standard with grease fittings

SEAT DESIGN

Valve is designed for abrasive service or for operation in temperature that prohibit the use of soft seat material. Seating faces are hard surface.

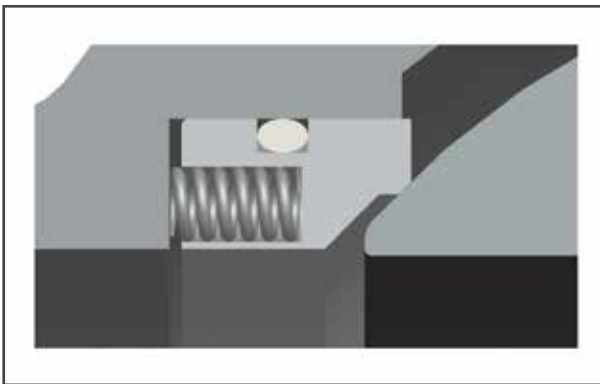

- Upstream seat 1/2" - 6", downstream seat 8" and above
- Bi-directional sealing with a preferred direction (optional direction available ←)
- Internal stem bushing absorbs stem loading
- Secondary seal (seal gasket)
- External thrust bearing slightly reduces valve torque
- Unique ball and seat spring loading technology
- Plasma spray custom trim coating technology with hardness in excess of 70 RC
- Superior ball and seat finish to 2-4 RMS
- Seat shroud eliminates particle migration into seat recess

PARTS IDENTIFICATION

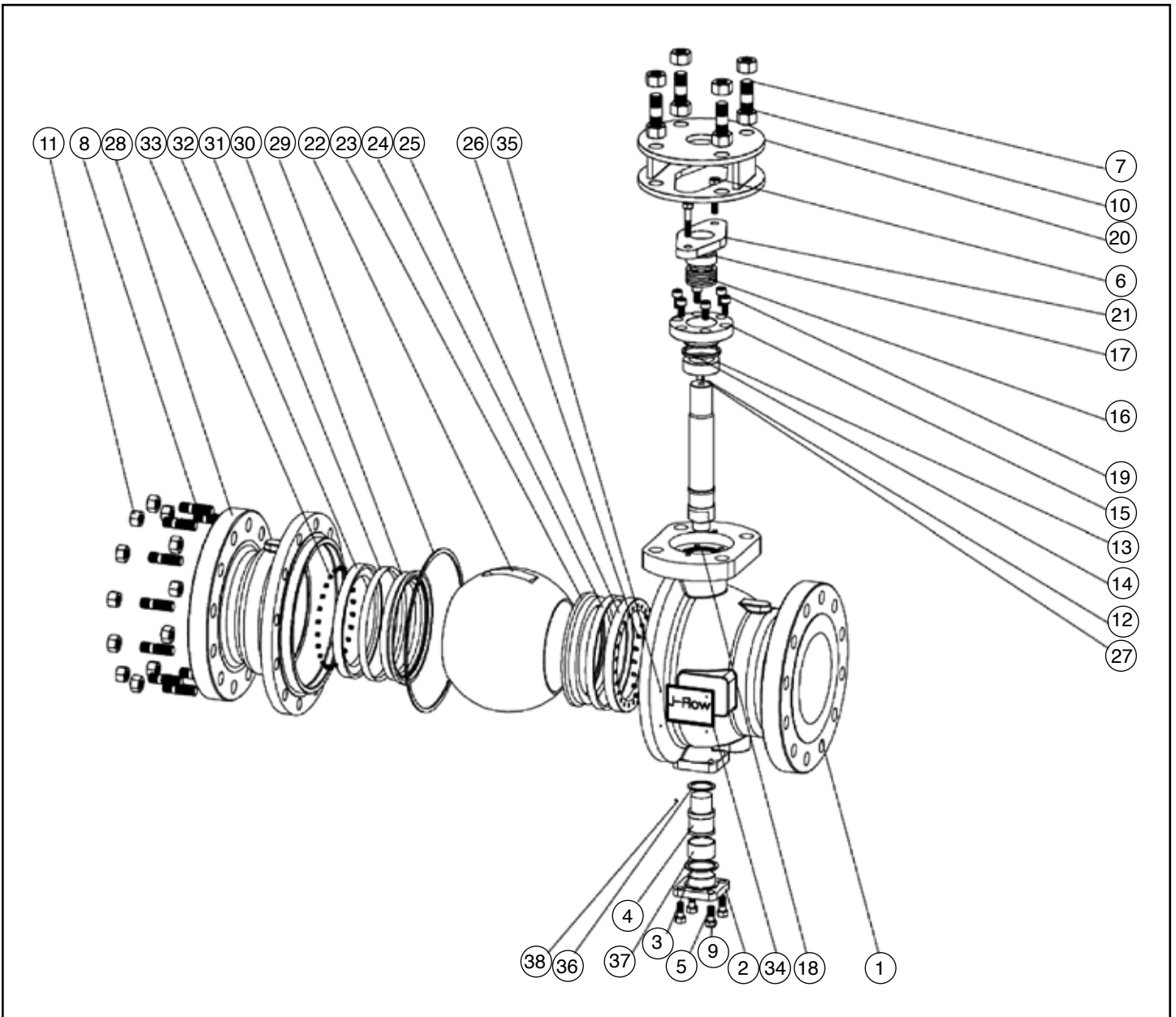

9800 Series Metal to Metal Trunnion Ball Valves

PARTS IDENTIFICATION

Part No.	Description	Qty	A105	WCB/13Cr	WCB/304	WCB/316	CF8	CF8M
1	Body	1	A105	ASTMA216WCB	ASTMA216WCB	ASTMA216WCB	ASTMA351CF8	ASTMA351CF8M
2	Body Cover	1	A105	ASTMA216WCB	ASTMA216WCB	ASTMA216WCB	ASTMA351CF8	ASTMA351CF8M
3	Gasket	1	Metal Graphite					
4	Trunnion	1	316, 410, Chrome Alloy					
5	Bolt	4	B8M, B7M, 304					
6	Bolt	2						
7	Bolt	4						
8	Bolt	12						
9	Nut	6						
10	Nut	8						
11	Nut	12	Chrome w/Electroless Nickel, 316/SS410 w/Tungsten Carbide Coating or Hard Chrome Coating on Ball, Alloy 20, Monel, Hastelloy, Chrome Alloy, AISI 410, A105 w/Electroless Nickel, 310 w/Electroless Nickel					
12	Stem	1						
13	Stem Housing	1						
14	Anti-blowout Ring	4	304 or 316					
15	Gland	1	Graphite or PTFE					
16	Packing	5						
17	Packing Press Ring	1	316					
18	Gasket	1	Spiral Wound Grafoil					
19	Stud	6	B8M, B7M, 304					
20	Bracket	1	A105	ASTMA216WCB	ASTMA216WCB	ASTMA216WCB	ASTMA351CF8	ASTMA351CF8M
21	Packing Gland	1	304 or 316					
22	Ball	1	Chrome w/Electroless Nickel, 316/SS410 w/Tungsten Carbide Coating or Hard Chrome Coating on Ball, Alloy 20, Monel, Hastelloy, Chrome Alloy, AISI 410, A105 w/Electroless Nickel, 310 w/Electroless Nickel					
23	Seat	1	AISI 410 + Tungsten Carbide (TCC), Metal 316 Stellite Overlay, Inconel Metal Seat, Metal Tungsten Carbide, Reinforced, TC Carbon TFM (Double Seated First Metal, Second Soft)					
24	Sealing Ring	1	316					
25	Seal Press Ring	1						
26	Spring	24	A105, 316, 316L, Inconel 750, Alloys, A105 with Electroless Nickel					
27	Key	1	Chrome w/Electroless Nickel, 316/SS410 w/Tungsten Carbide Coating or Hard Chrome Coating on Ball, Alloy 20, Monel, Hastelloy, Chrome Alloy, AISI 410, A105 w/Electroless Nickel, 310 w/Electroless Nickel					
28	Cap	1	A105	ASTMA216WCB	ASTMA216WCB	ASTMA216WCB	ASTMA351CF8	ASTMA351CF8M
29	Seat Gasket	1	Spiral Wound Graphite					
30	Seat	1	AISI 410 + Tungsten Carbide (TCC), Metal 316 Stellite Overlay, Inconel Metal Seat, Metal Tungsten Carbide, Reinforced, TC Carbon TFM (Double Seated First Metal, Second Soft)					
31	Sealing Ring	1	316					
32	Sealing Press Ring	1						
33	Spring	24	A105, 316, 316L, Inconel 750, Alloys, A105 with Electroless Nickel					
34	Name Plate	1	304					
35	Rivet	4						
36	Thrust Bearing	1	Grafoil					
37	Slide Bearing	1						
38	Anti-static Spring	2	304 or 316					

9800 Series Metal to Metal Trunnion Ball Valves

DIMENSIONS - ASME CLASS 150 FULL BORE (IN)

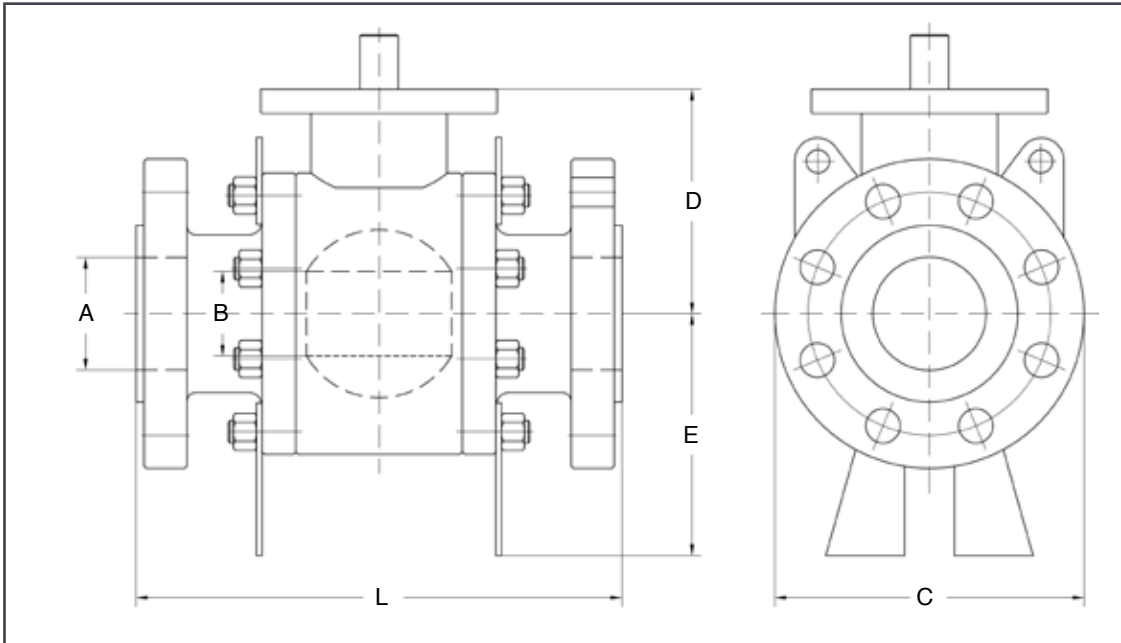

Size (in)	A	B	L-RF	L-WE	C	D	E	Weight
2	1.93	1.93	7	8.50	6.02	4.17	4.02	59
3	2.91	2.91	8	11.13	7.52	6.18	4.96	119
4	3.94	3.94	9	12	9.13	7.80	6.42	196
6	5.91	5.91	15.5	18	12.1	9.72	7.36	352
8	7.91	7.91	18	20.5	15.4	11.0	8.82	557
10	9.92	9.92	21	22	18.3	12.6	10.9	857
12	11.9	11.9	24	25	21.4	13.3	12.1	1230
14	13.2	13.2	27	30	23.9	14.7	13.2	1672
16	15.2	15.2	30	33	26.6	16.1	14.1	2244
18	17.2	17.2	34	36	25.0	17.3	15.4	2673
20	19.2	19.2	36	39	33.4	19.4	17.1	3945
22	21.2	21.2	40	43	36.8	20.8	18.8	5190
24	23.2	23.2	42	45	39.6	23.2	20.6	6818
26	24.9	24.9	45	49	42.0	24.7	22.2	8107
28	26.9	26.9	49	53	44.7	25.4	25.9	9878
30	28.9	28.9	51	55	38.8	27.2	27.7	11473
32	30.7	30.7	54	60	51.2	29.4	29.4	14960
34	32.7	32.7	58	64	53.9	30.4	30.4	17160
36	34.4	34.4	60	68	56.3	31.8	31.8	19360
40	38.4	38.4	69	77	62.8	35.4	35.4	27632
42	40.2	40.2	70	82	65.0	36.9	36.9	31416
48	45.9	45.9	78	94	75.6	42.0	42.0	48180
56	53.5	53.5	98	98	90.9	49.3	49.3	70520

9800 Series Metal to Metal Trunnion Ball Valves

DIMENSIONS - ASME CLASS 150 REDUCED BORE (IN)

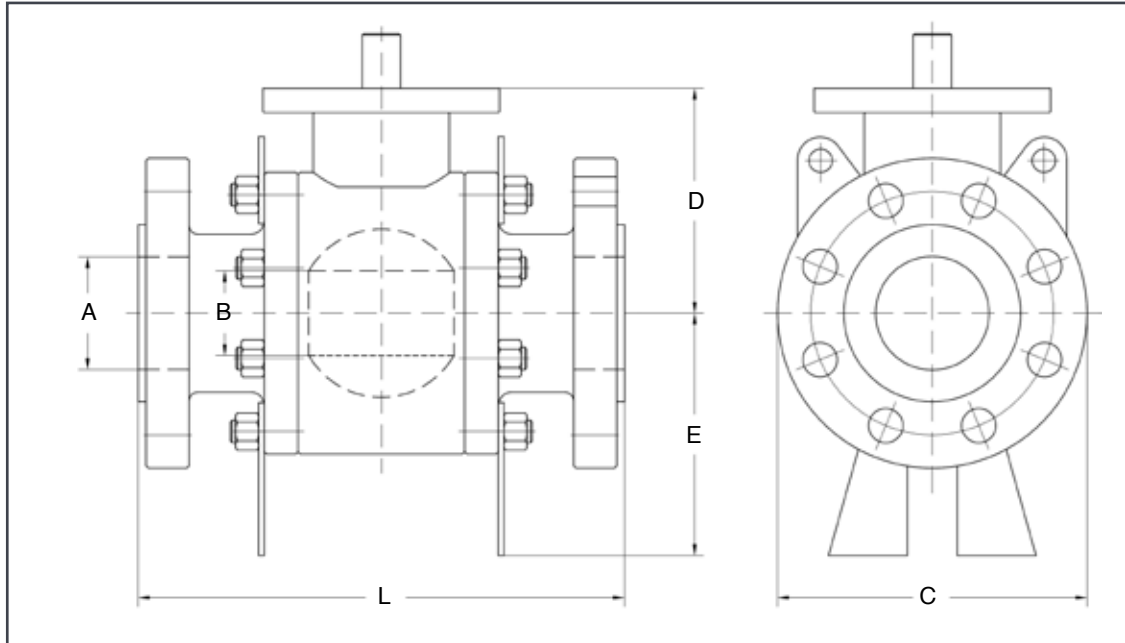

Size (in)	A	B	L-RF	L-WE	C	D	E	Weight
2x1-1/2	1.93	1.50	7	8.5	5.98	3.70	3.86	55
3 x 2	2.91	1.93	11.13	11.1	7.52	4.17	3.94	66
4 x 3	3.94	2.91	12	12	9.02	6.06	5.00	132
6 x 4	5.91	3.94	15.5	18	10.98	7.80	6.42	220
8 x 6	7.91	5.91	18	20.5	13.50	9.92	7.36	407
10 x 8	9.92	7.91	21	22	15.98	11.02	8.74	640
12 x 10	11.93	9.92	24	25	19.02	12.72	11.02	1016
14 x 10	13.15	9.92	27	30	21.06	12.76	10.83	1140
14 x 12	13.15	11.93	27	30	21.06	13.46	11.81	1342
16 x 12	15.16	11.93	30	33	23.43	13.62	11.93	1536
16 x 14	15.16	13.15	30	33	23.43	14.57	13.19	1804
18 x 16	17.17	15.16	34	36	25.00	16.34	13.70	2332
20 x 16	19.17	15.16	36	39	27.56	16.34	13.78	2420
20 x 18	19.17	17.17	36	39	27.56	17.28	15.35	2618
24 x 20	23.19	19.17	42	45	32.09	19.29	17.13	4334
30 x 24	28.94	23.19	51	55	38.78	23.15	20.28	7150
36 x 30	34.41	28.94	60	68	46.06	27.17	27.56	13891

9800 Series Metal to Metal Trunnion Ball Valves

DIMENSIONS - ASME CLASS 300 FULL BORE (IN)

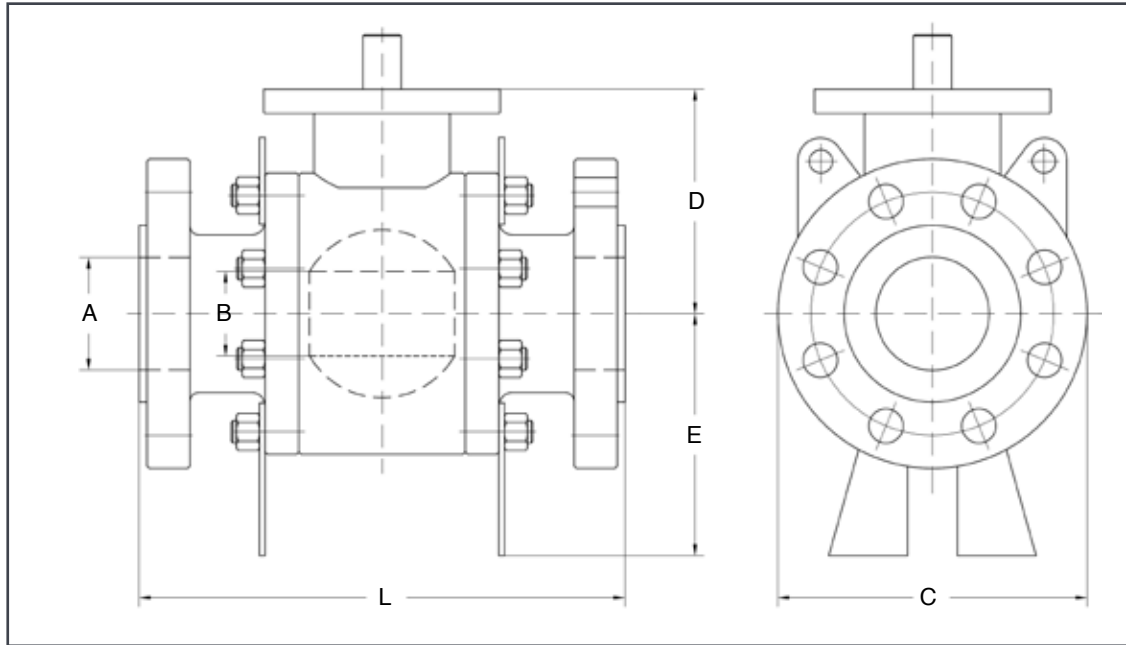

Size (in)	A	B	L-RF	L-WE	C	D	E	Weight
2	1.93	1.93	8.5	8.5	6.5	3.9	3.7	59
3	2.91	2.91	11.1	11.1	8.3	5.9	4.7	121
4	3.94	3.94	12.0	12.0	10	7.9	6.3	202
6	5.91	5.91	15.19	15.19	12.5	9.6	7.9	400
8	7.91	7.91	19.8	19.8	15.2	10.8	9.1	612
10	9.92	9.92	22.4	22.4	18.5	13.0	11.6	1100
12	11.9	11.9	25.5	25.5	21.3	14.0	13.0	1613
14	13.2	13.2	30	30	24.8	15.4	13.6	2264
16	15.2	15.2	33	33	27.3	16.9	15.4	3120
18	17.2	17.2	36	36	30.3	17.9	16.1	3502
20	19.2	19.2	39	39	33.5	19.7	18.3	4829
22	21.2	21.2	43	43	37	20.7	18.9	6134
24	23.2	23.2	45	45	40.2	23.2	21.5	7612
26	24.9	24.9	49	49	42.5	24.8	22.8	10252
28	26.9	26.9	53	53	45.3	25.2	26.2	12694
30	28.9	28.9	55	55	48.6	27.6	28.7	14498
32	30.7	30.7	60	60	52	29.3	30.1	17450
34	32.7	32.7	64	64	54.7	29.9	31.5	19888
36	34.4	34.4	68	68	56.9	31.7	32.5	22205
40	38.4	38.4	77	77	63.8	35.4	36.2	30305
42	40.2	40.2	82	82	66.3	38.1	37.4	35431
48	45.9	45.9	85	85	57.5	43.3	43.3	52932
56	53.5	53.5	108	108	89.6	50.6	50.0	83941

9800 Series Metal to Metal Trunnion Ball Valves

DIMENSIONS - ASME CLASS 300 REDUCED BORE (IN)

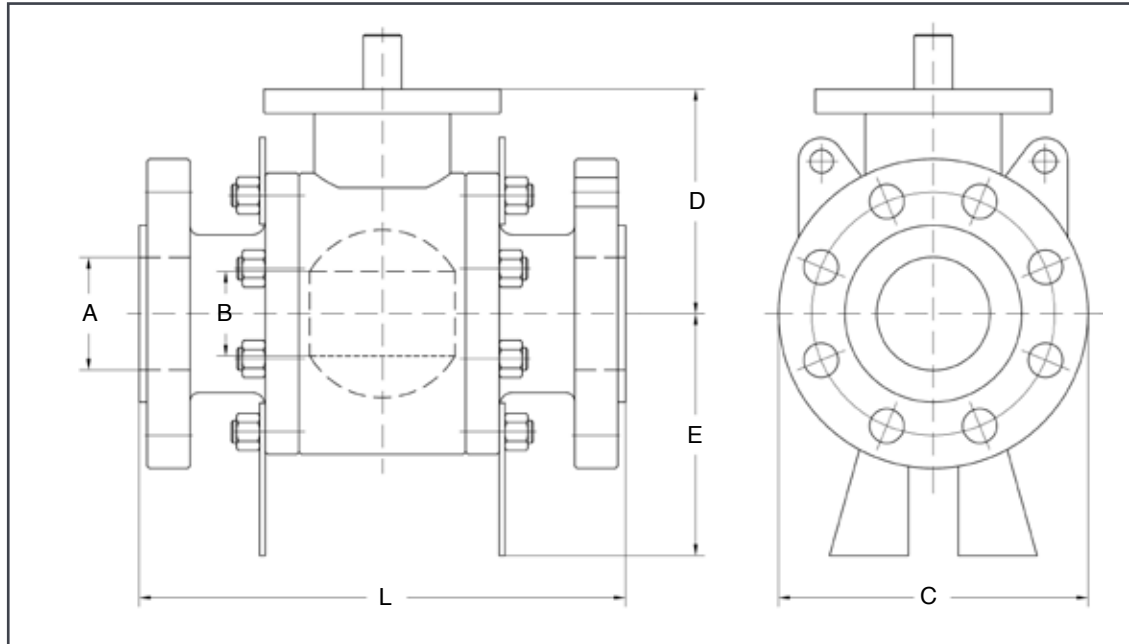

Size (in)	A	B	L-RF	L-WE	C	D	E	Weight
2x1-1/2	1.93	1.50	8.5	8.5	6.5	3.7	3.9	55
3 x 2	2.91	1.93	11.1	11.1	8.3	3.9	3.7	70
4 x 3	3.94	2.91	12.0	12.0	10.0	5.9	4.7	136
6 x 4	5.91	3.94	15.9	15.9	12.5	7.9	6.3	253
8 x 6	7.91	5.91	19.8	19.8	15.0	9.6	7.9	482
10 x 8	9.92	7.91	22.4	22.4	17.5	10.8	9.1	642
12 x 10	11.93	9.92	25.5	25.5	20.5	13	11.6	1307
14 x 10	13.15	9.92	30	30	23	13	11.6	1415
14 x 12	13.15	11.93	30	30	23	14	13	1795
16 x 12	15.16	11.93	33	33	25.6	14	13	2123
16 x 14	15.16	13.15	33	33	25.6	15.4	13.6	2475
18 x 16	17.17	15.16	36	36	28	16.9	15.4	3505
20 x 16	19.17	15.16	39	39	30.5	16.9	15.4	3659
20 x 18	19.17	17.17	39	39	30.5	17.9	16.1	3942
24 x 20	23.19	19.17	45	45	36	19.7	18.3	5854
30 x 24	28.94	23.19	55	55	42.9	23.2	21.5	9565
36 x 30	34.41	28.94	68	68	50	27.6	28.7	18003

9800 Series Metal to Metal Trunnion Ball Valves

DIMENSIONS - ASME CLASS 600 FULL BORE (IN)

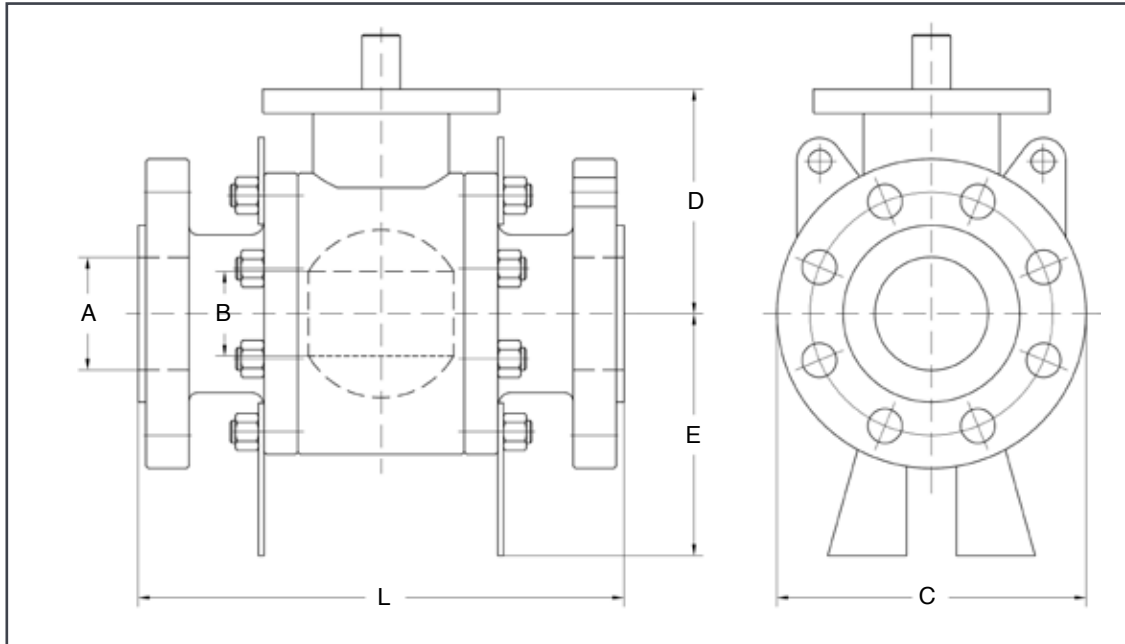

Size (in)	A	B	L-RF	L-RTJ	L-WE	C	D	E	Weight
2	1.93	11.5	11.5	11.63	11.5	6.5	4.0	3.9	68
3	2.91	14	14	14.13	14	8.3	6.5	5.0	136
4	3.94	17	17	17.13	17	10	8.3	6.3	249
6	5.91	22	22	22.13	22	14	9.8	7.9	557
8	7.91	26	26	26.13	26	16.5	11.3	10.0	1037
10	9.92	31	31	31.13	31	20.1	13.0	12.1	1668
12	11.93	33	33	33.13	33	22.6	14.9	13.7	2347
14	13.15	35	35	35.13	35	24.7	15.5	14.2	2383
16	15.16	39	39	39.13	39	27.6	16.9	16.1	3355
18	17.17	43	43	43.13	43	30.5	18.4	16.9	4609
20	19.17	47	47	47.3	47	34.1	19.7	19.4	5804
22	21.18	51	51	51.4	51	37.4	37.4	19.9	8331
24	23.19	55	55	55.4	55	40.5	23.4	22.4	10419
26	24.92	57	57	57.5	57	40.0	24.8	24.3	12423
28	26.93	61	61	61.5	61	46.1	26.2	27.2	14868
30	28.94	66	66	65.5	66	50.8	29.2	31.5	18429
32	30.67	70	70	70.7	70	52.4	29.8	31.7	21424
34	32.68	76	76	76.5	76	55.1	30.8	32.2	24939
36	34.41	82	82	80.6	82	60.9	34.2	37.2	29256
40	38.43	82	82	85.6	85	64.8	36.1	38.6	40337
42	40.16	86	86	85.6	86	70.7	39.2	43.7	46983
48	45.91	96	96	98.6	96	81.5	44.6	49.8	68629
56	53.54	107	107	107	107	94.1	50.8	57.1	104463

9800 Series Metal to Metal Trunnion Ball Valves

DIMENSIONS - ASME CLASS 600 REDUCED BORE (IN)

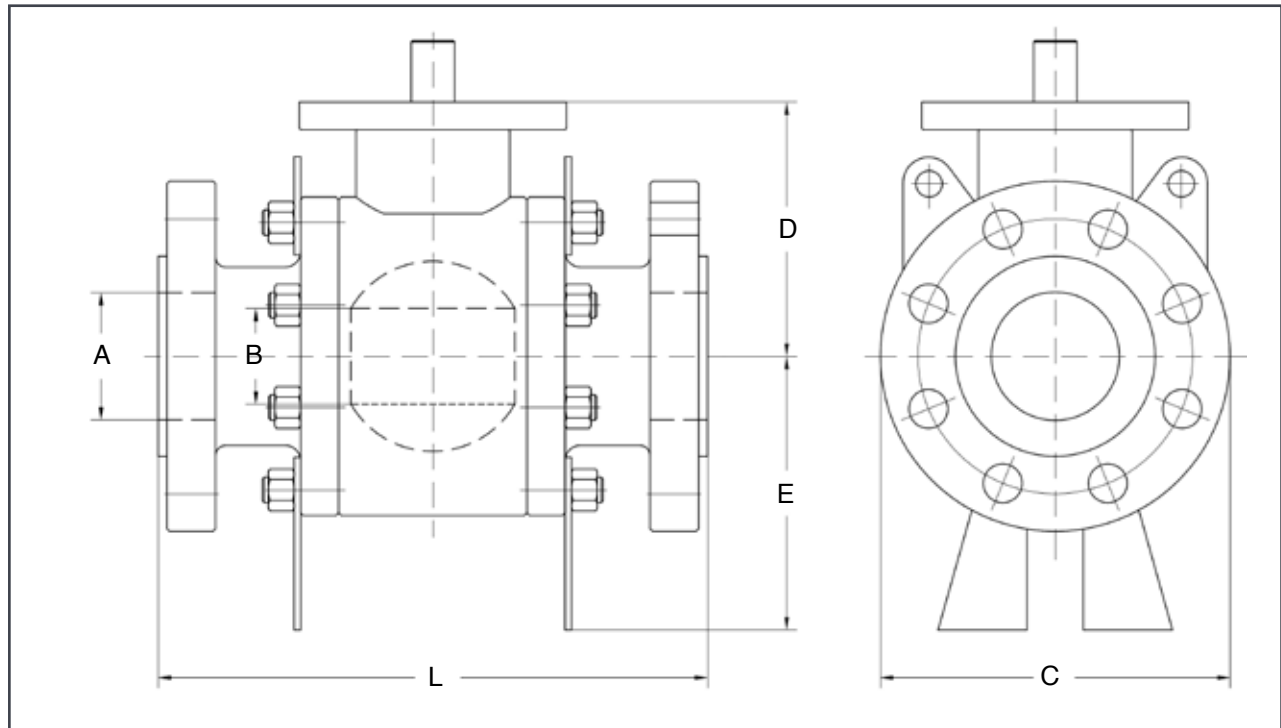

Size (in)	A	B	L-RF	L-RTJ	L-WE	C	D	E	Weight
2x1-1/2	1.93	1.50	11.5	11.63	11.5	3.7	3.7	4.0	68
3 x 2	2.91	1.93	14	14.13	14	3.9	4.0	3.9	86
4 x 3	3.94	2.91	17	17.13	17	5.9	6.5	5.0	172
6 x 4	5.91	3.94	22	22.13	14	7.9	8.3	6.3	330
8 x 6	7.91	5.91	26	26.13	16.5	9.6	9.8	7.9	642
10 x 8	9.92	7.91	31	31.13	20.1	10.8	11.3	10.0	1210
12 x 10	11.93	9.92	33	33.13	22	13	13	12.1	1784
14 x 10	13.15	9.92	35	35.13	23.8	13	13	12.1	2006
14 x 12	13.15	11.93	35	35.13	23.8	14	14.9	13.7	2519
16 x 12	15.16	11.93	39	39.13	27	14	14.9	13.7	2966
16 x 14	15.16	13.15	40	39.13	24.7	15.4	15.5	14.2	2383
18 x 16	17.17	15.16	43	43.13	29.3	16.9	16.9	16.1	3696
20 x 16	19.17	15.16	47	47.25	32.1	16.9	16.9	16.1	4587
20 x 18	19.17	17.17	47	47.25	32.1	17.9	18.4	16.9	5225
24 x 20	23.19	19.17	55	55.38	37	19.7	19.7	19.4	7146
30 x 24	28.94	23.19	66	65.5	44.5	23.2	23.4	22.4	12690
36 x 30	34.41	28.94	82	82.63	51.8	27.6	27.9	29.6	22827

9800 Series Metal to Metal Trunnion Ball Valves

DIMENSIONS - ASME CLASS 900 FULL BORE (IN)

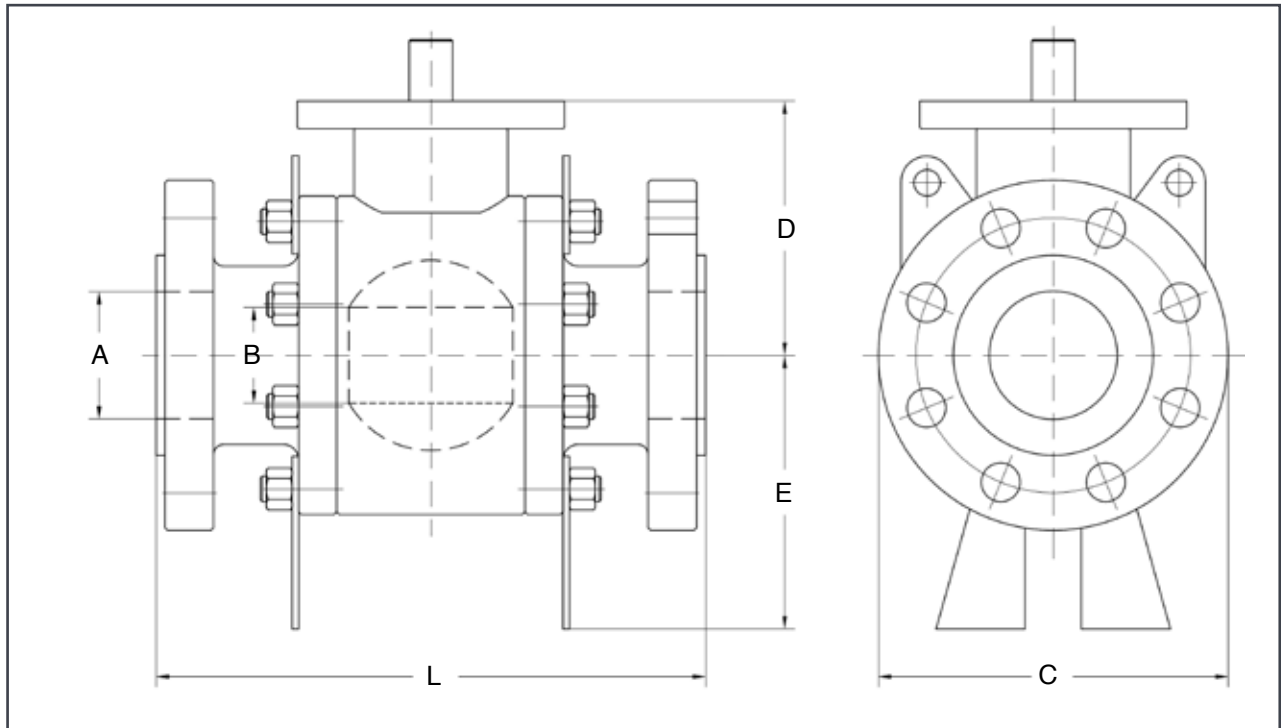

Size (in)	A	B	L-RF	L-RTJ	L-WE	C	D	E	Weight
2	1.93	1.93	14.5	14.61	14.5	8.50	4.09	4.06	106
3	2.91	2.91	15	15.12	15	9.49	6.42	5.20	121
4	3.94	3.94	18	18.11	18	11.5	8.31	6.65	319
6	5.91	5.91	24	24.13	24	15	10.20	8.39	792
8	7.91	7.91	29	29.13	29	18.5	11.69	10.39	1276
10	9.92	9.92	33	33.11	33	21.5	13.46	13.11	2222
12	11.9	11.9	38	38.11	38	24	15.12	14.92	3322
14	12.7	12.7	40.5	40.87	40.5	25.2	15.67	14.49	3190
16	14.7	14.7	44.5	44.88	44.5	27.95	17.17	17.20	4730
18	16.7	16.7	48	48.50	48	31.5	19.06	19.47	6204
20	18.5	18.5	52	52.84	52	35.0	20.94	19.80	9240
24	22.4	22.4	61	61.73	61	41.7	24.29	24.92	14960
28	26.2	26.2	69	69.88	69	48.58	26.54	27.80	21780
30	28.0	28.0	74	74.88	74	51.18	28.46	30.59	26796
32	29.9	29.9	80	80.87	80	53.43	30.87	31.85	26004
34	31.8	31.8	85	86.14	85	57.8	31.77	33.54	37840
36	33.7	33.7	90	91.14	90	60.3	33.39	35.35	41580

9800 Series Metal to Metal Trunnion Ball Valves

DIMENSIONS - ASME CLASS 900 REDUCED BORE (IN)

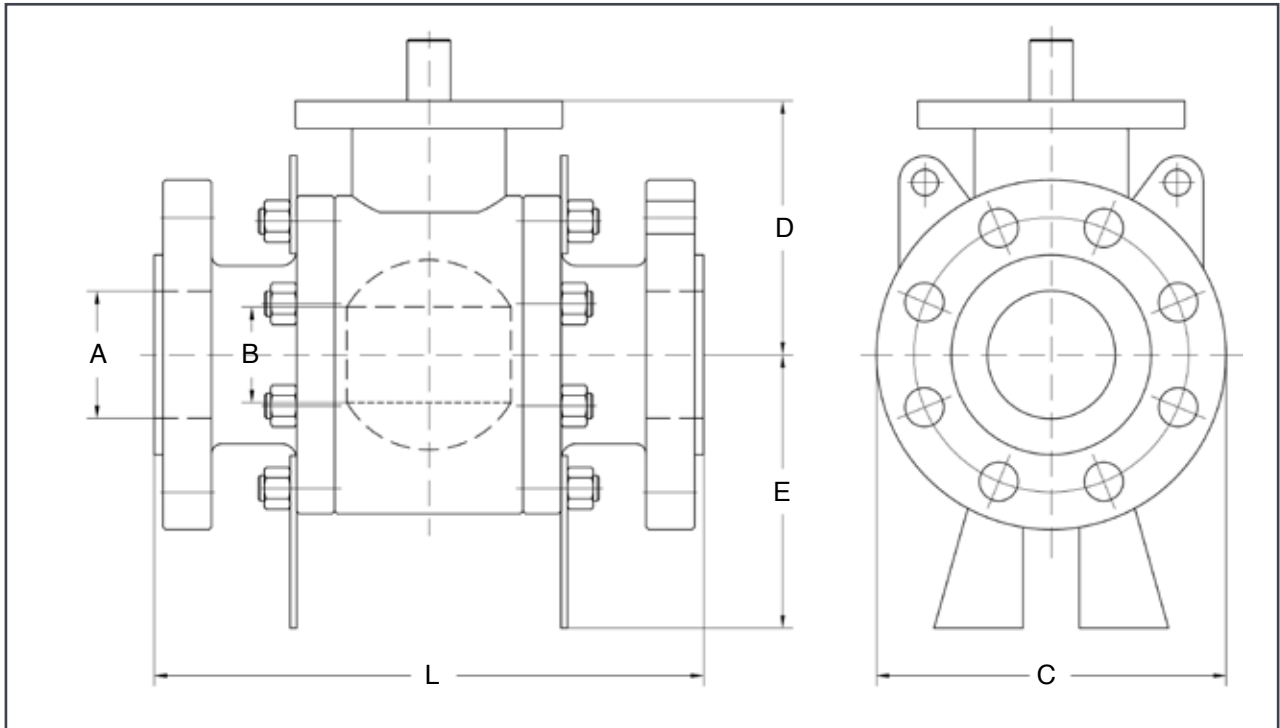

Size (in)	A	B	L-RF	L-RTJ	L-WE	C	D	E	Weight
2x1-1/2	1.93	1.50	14.5	14.6	14.5	8.50	4.06	4.02	90
3 x 2	2.91	1.93	15	15.1	15	9.49	4.06	4.02	114
4 x 3	3.94	2.91	18	18.1	18	11.5	6.54	5.00	209
6 x 4	5.91	3.94	24	24.1	24	15.0	8.19	6.42	451
8 x 6	7.91	5.91	29	29.1	29	18.5	10.4	8.39	968
10 x 8	9.92	7.91	33	33.1	33	21.5	11.8	10.6	1518
12 x 10	11.9	9.92	38	38.1	38	24.0	13.7	12.9	2541
14 x 10	12.7	9.92	40.5	40.9	40.5	25.2	13.7	12.9	2728
14 x 12	12.7	11.93	40.5	40.9	40.5	25.2	15.8	15.0	3597
16 x 12	14.7	11.93	44.5	44.9	44.5	27.8	15.8	15.0	3806
16 x 14	14.7	12.68	44.5	44.9	44.5	27.6	15.8	17.3	3740
18 x 16	16.7	14.69	48	48.5	48	31.1	17.3	17.4	5368
20 x 16	18.5	14.69	52	52.5	52	31.1	17.3	17.4	6325
20 x 18	18.5	16.65	52	52.5	52	33.7	18.9	19.1	7150
24 x 20	22.4	18.54	61	61.7	61	40.9	21.0	19.7	11880
30 x 24	28.0	22.44	74	74.9	74	48.4	23.9	24.9	19140
36 x 30	33.7	28.03	90	90.0	90	57.5	28.7	30.9	33770

9800 Series Metal to Metal Trunnion Ball Valves

DIMENSIONS - ASME CLASS 1500 FULL BORE (IN)

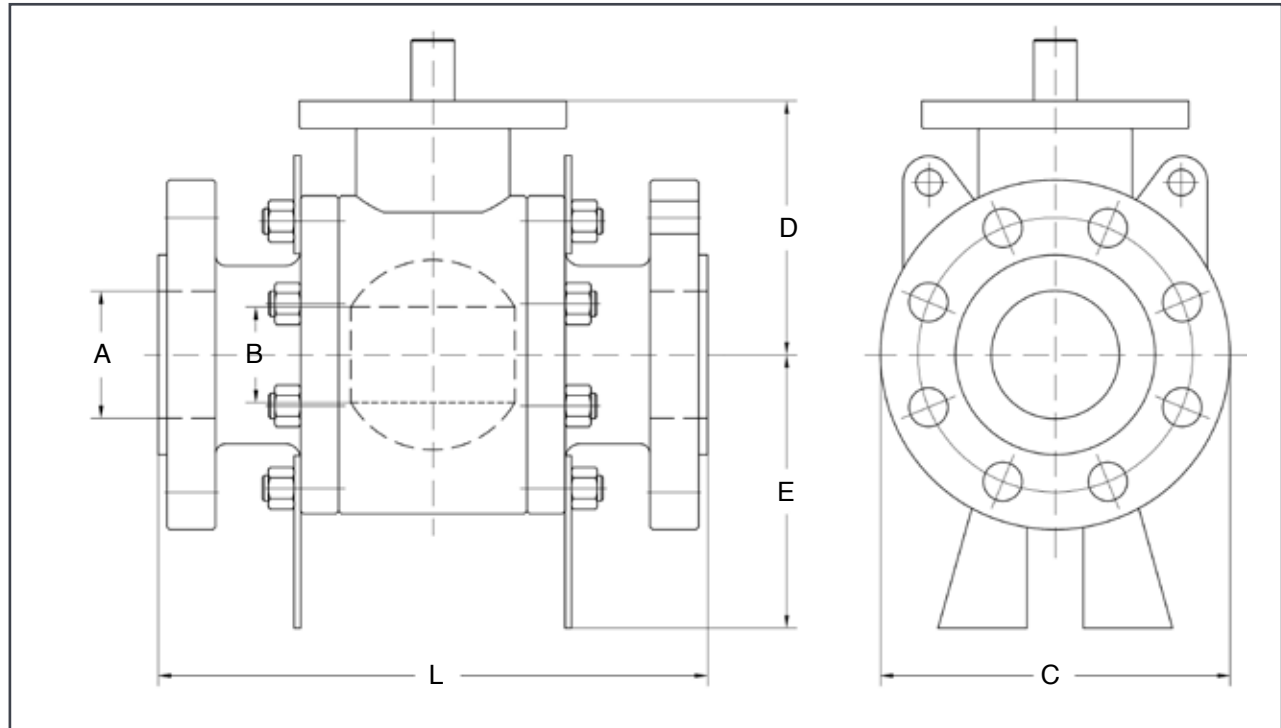

Size (in)	A	B	L-RF	L-RTJ	L-WE	C	D	E	Weight
2	1.93	1.93	14.5	14.6	14.5	8.50	4.17	4.02	110
3	2.91	2.91	18.5	18.6	18.5	10.5	6.57	5.04	213
4	3.94	3.94	21.5	21.6	21.5	12.2	7.05	6.69	436
6	5.67	5.67	27.8	278.0	27.8	15.5	10.2	9.17	1056
8	7.56	7.56	32.8	33.1	32.8	19.0	12.0	11.4	1804
10	9.41	9.41	39.0	39.4	39.0	23.0	14.3	13.9	3300
12	11.3	11.3	44.5	45.1	44.5	27.9	16.4	16.7	4950
14	12.4	12.4	49.5	50.2	49.5	30.1	17.2	16.8	6270
16	14.2	14.2	54.5	55.4	54.5	33.4	18.7	19.4	8954
18	15.9	15.9	58.2	59.0	60.5	38.6	22.1	23.9	13629
20	17.9	17.9	65.5	66.4	65.5	40.0	24.3	25.4	19965
24	20.9	20.9	70.2	71.3	80.4	50.9	27.5	28.5	31416

9800 Series Metal to Metal Trunnion Ball Valves

DIMENSIONS - ASME CLASS 2500 FULL BORE (IN)

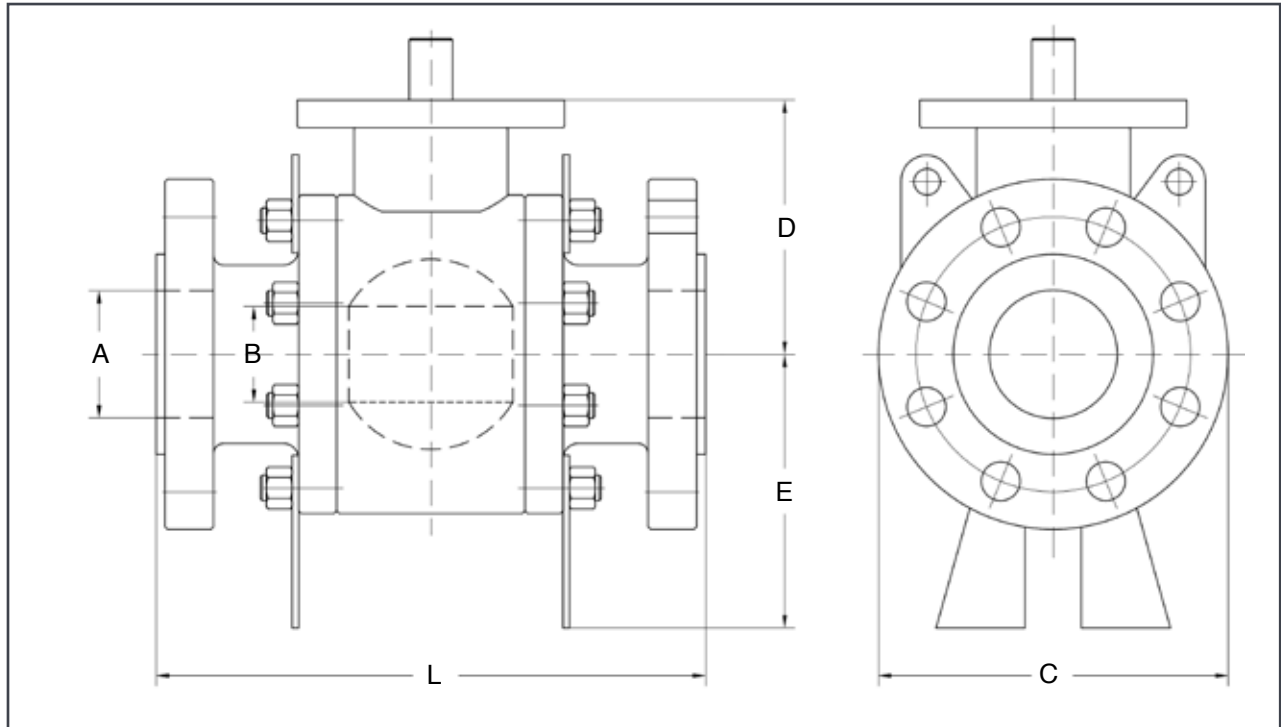

Size (in)	A	B	L-RF	L-RTJ	L-WE	C	D	E	Weight
2	1.65	1.65	17.76	17.9	17.8	9.25	472	5.00	194
3	2.44	2.44	22.76	23.0	22.8	12.0	6.97	7.80	411
4	3.43	3.43	26.50	26.9	26.5	14.0	8.94	9.17	836
6	5.16	5.16	35.98	36.5	36.0	19.0	10.4	9.92	1694
8	7.05	7.05	40.24	40.9	40.2	24.4	15.1	13.4	2985
10	8.78	8.78	50.0	50.9	50.0	29.3	17.8	16.6	4620
12	10.43	10.43	56.0	56.9	56.0	34.3	20.5	19.0	7062

9800 Series Metal to Metal Trunnion Ball Valves

HOW TO ORDER

Series	Series	Body ¹ , Ball & Stem	Spring	Port
7	2"	00 CF8	2 A105	F Full
8	2-1/2"	0L CF3	3 316	R Reduced
9	3"	11 LF5	L 316L	
A	4"	23 WCB, CF8M Ball & Stem	X Inconel 750	
C	6"	33 CF8M	Y Alloys	
E	8"	44 Alloy 20	Z A105 w/electroless nickel	
F	10"	55 Monel		
G	12"	6L CF3M		
H	14"	77 Hastelloy C		
K	16"	88 LF2/LCB 17-4 Stem		
L	18"	83 LCB, CF8M Ball & Stem		
M	20"	99 Duplex		
N	22"	AA A105 with Chrome		
O	24"	AB A105, AISI 410 trim		
P	36"	EE A105 with Electroless Nickel Ball & Stem		
S	40"			
T	60"			

Chevron Packing	Seat	End Connection	Options
G Graphoil	B AISI 410 + Tungsten Carbide (TCC)	B Butt Weld	GO Gear Operator
	M Metal 316 Stellite Overlay	S Socket Weld	FS Fire Safe
	I Inconel Metal Seat	F Flanged	SE Stem Extension
	MT Metal Tonsten Carbide	FF Flat Face	VB Vented Ball
	R Reinforced	F1 ANSI 150	
	TC* Carbon TFM	F3 ANSI 300	
		F6 ANSI 600	
		F9 ANSI 900	
		F15 ANSI 1500	
		F25 ANSI 2500	
	RTJ Ring Type Joint		

* Double Seated, First Metal, Second Soft

¹ Please see the J Flow Controls Configurator for a full list of body materials

J Flow Controls®
4665 Interstate Drive
Cincinnati, OH 45246
513-731-2900
jflowcontrols.com

While the information and specifications contained in this literature are believed to be accurate, they are supplied for informative purposes only and should not be considered certified or a guarantee of satisfactory results. Nothing contained herein is to be construed as a warranty or guarantee, express or implied, regarding any matter with respect to this product. Because J Flow Controls® is continually improving and upgrading its product design, the specifications, dimensions and information contained herein are subject to change without notice.