



STANDARDS

- Meets ASME B16.5, B16.10, and B16.34, Rev. 5/ISO 10497
- ASME Section 8 cover/body flange connection and bolting
- Wall thickness complies with ASME B16.34
- AGA and CGA approved, regular port, threaded ends (optional) 1/2" - 12"
- Fire safe design

J Flow Controls 9400 Series Top Entry Valves

FEATURES & BENEFITS

- Full port 1/2" - 10"; Regular port 1/2" - 12" threaded, socket weld, butt weld, and flanged ANSI 150 - 2500
- Seats compensate for wear and fluctuations of pressure and temperature
- Multiple solid cup and cone type PTFE stem seal or graphite packing
- Two-piece self-aligning packing flange and gland
- Stem guides in cover and gland bushing eliminate side thrust
- Longer cycle life
- Lower, uniform torque
- Live-loaded thrust washer prevents galling and provides a secondary stem seal
- Fully-enclosed spiral wound graphite filled stainless steel body gasket
- Permits in-line access for seat replacement
- Body-cover joint not affected by pipe stresses
- Can be welded into line without disassembly
- MTS reports available

APPLICATIONS & INDUSTRIES

- All fluids
- Slurries
- Semi-solids
- Corrosive services
- Industrial
- Chemical
- Original equipment

FEATURES

Top Entry

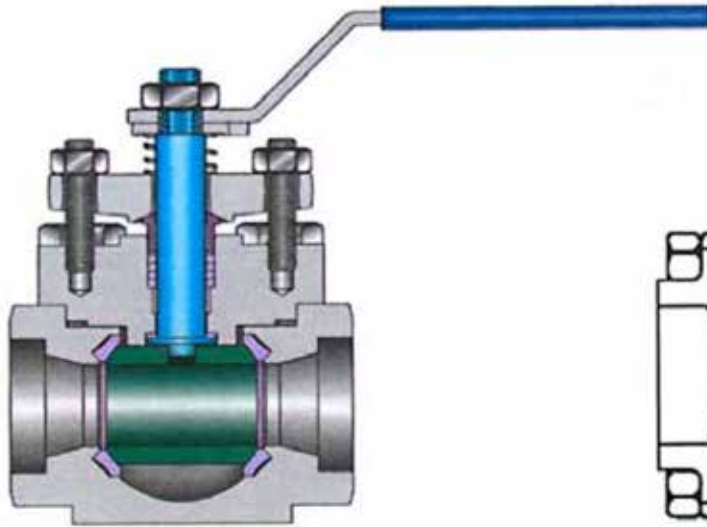

1. Two leakage paths (gasket and packing)
2. Fully guided stem
3. In lab test 0 ppm emissions to 100,000 cycles, 500,000 with live-loading
4. Easy to weld the one-piece body into the line without disassembly. The integrity of the valve is not affected
5. All parts can be easily serviced or replaced in-line

Three-Piece Valves

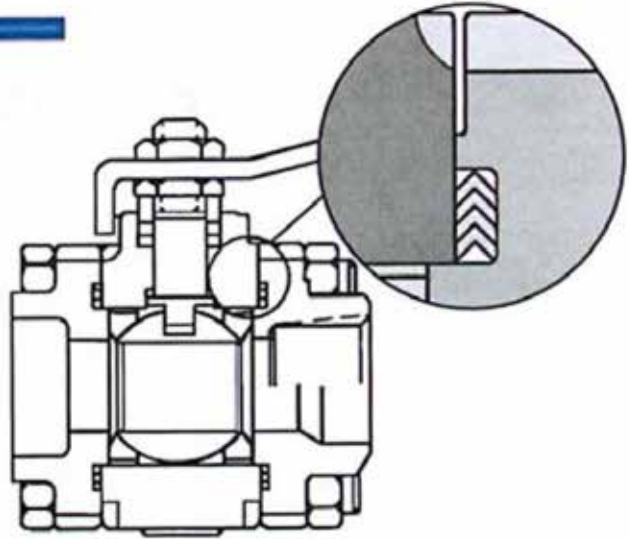

1. Three leakage paths (2 gasket and packing)
2. Fully guided stem
3. Stem can wobble, cause leakage
4. Greater emissions, lower cycle life
5. Welding can affect the integrity of the valve due to tendency to separate the three-bolted body parts during the welding
6. Valve can not be serviced in-line, because the fire safe design with spiral-wound gaskets requires internal guiding of the two end pieces. The guiding prevents the centerpiece from swinging out.

9400 Series Top Entry Valve

DIMENSIONS - ANSI CLASS 150, 300 (INCHES)

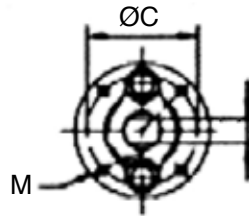
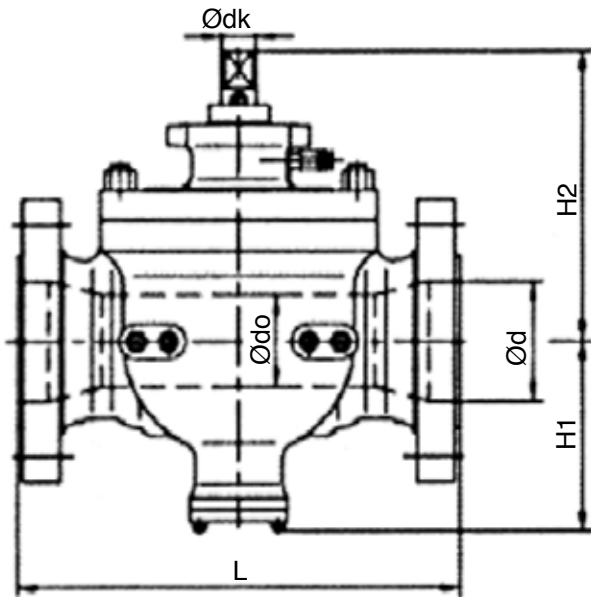

Size 2" ~ 4"

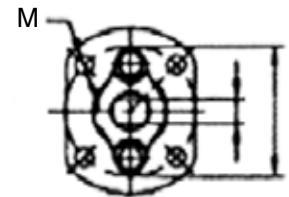

Size 6" ~ 10"

Valve Size	Ødo	Ød	L (RF)		H1	H2	Ødk	ØC	K	M
			150 Lb	300 Lb						
2"	1.93	--	* 11.50		4.13	5.59	0.79	2.76	0.47	4-M8
3" x 2"	1.93	2.91	△ 11.14		4.13	5.59	0.79	2.76	0.47	4-M8
3"	2.91	--	* 14.02		4.92	7.68	1.06	2.76	0.67	4-M8
4" x 3"	2.91	3.94	△ 12.01		4.92	7.68	1.06	2.76	0.67	4-M8
4"	3.94	--	* 17.01		5.94	8.62	1.34	4.02	0.87	4-M10
6" x 4"	3.94	5.91	15.51	15.87	5.94	8.62	1.34	4.02	0.87	4-M10
6"	5.91	--	* 22.01		7.24	7.95	1.73	5.51	1.06	4-M16
8" x 6"	5.91	7.91	17.99	19.76	7.24	7.95	1.73	5.51	1.06	4-M16
8"	7.91	--	* 25.98		10.79	11.61	2.01	6.50	1.26	4-M20
8" x 10"	7.91	9.92	20.98	22.36	10.79	11.61	2.01	6.50	1.26	4-M20
10"	9.92	--	* 30.98		12.52	13.31	2.01	6.50	1.26	4-M20
12" x 10"	9.92	11.93	24.02	25.51	12.52	13.31	2.01	6.50	1.26	4-M20

Note:

* Designed as per 600 lb length

△ Designed as per 300 lb length

9400 Series Top Entry Valve

DIMENSIONS - ANSI CLASS 600 (INCHES)

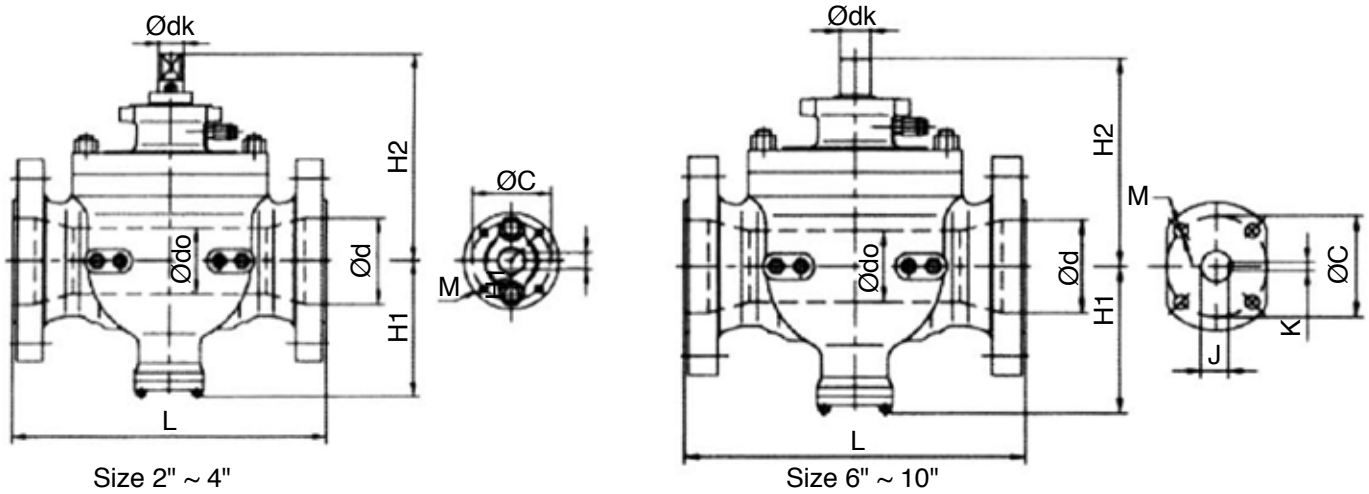

Valve Size	Ødo	Ød	L (RF)		H1	H2	Ødk	ØC	J	K	M
			400 Lb	600 Lb							
2"	1.93	--	11.50		4.84	6.85	1.06	2.76	--	0.67	4-M8
3" x 2"	1.93	2.91	14.02		4.84	6.85	1.06	2.76	--	0.67	4-M8
3"	2.91	--	14.02		5.83	8.07	1.34	4.02	--	0.87	4-M10
4" x 3"	2.91	3.94	15.98	17.01	5.83	8.07	1.34	4.02	--	0.87	4-M10
4"	3.94	--	15.98	17.01	7.01	10.87	1.73	5.51	--	1.06	4-M16
6" x 4"	3.94	5.91	19.49	22.01	7.01	10.87	1.73	5.51	--	1.06	4-M16
6"	5.91	--	19.49	22.01	9.53	13.31	1.97	6.50	1.75	0.55	4-Ø23
8" x 6"	5.91	7.91	23.50	25.98	9.53	13.31	1.97	6.50	1.75	0.55	4-Ø23
8"	7.91	--	23.50	25.98	12.20	16.10	2.52	10.00	2.28	0.71	8-Ø19
8" x 10"	7.91	9.92	26.50	30.98	12.20	16.10	2.52	10.00	2.28	0.71	8-Ø19
10"	9.92	--	26.50	30.98	14.29	18.46	2.52	10.00	2.28	0.71	8-Ø19
12" x 10"	9.92	11.93	30.00	32.99	14.29	18.46	2.52	10.00	2.28	0.71	8-Ø19

DIMENSIONS ANSI CLASS 900 (INCHES)

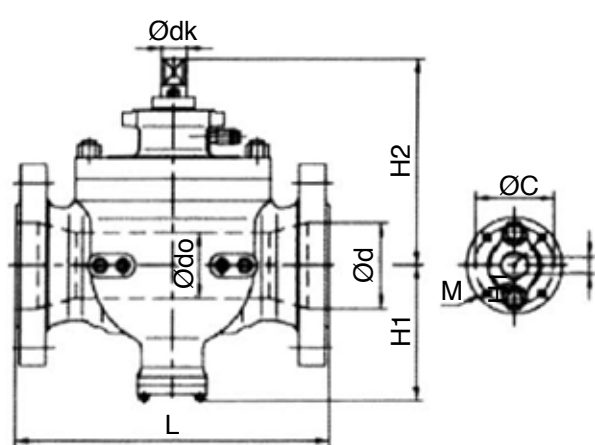

Size 2" ~ 3"

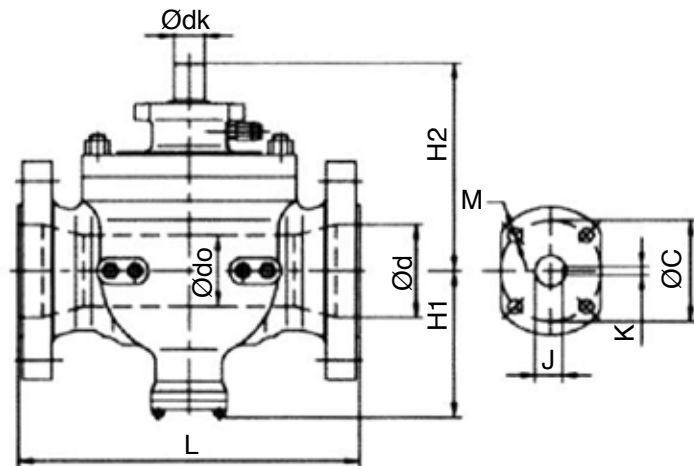

Size 4" ~ 6"

Valve Size	Ødo	Ød	L (RTJ)	H1	H2	Ødk	ØC	J	K	M
2"	1.93	--	14.61	6.42	8.70	1.34	4.02	--	0.87	4-M10
3" x 2"	1.93	2.91	15.12	6.42	8.70	1.34	4.02	--	0.87	4-M10
3"	2.91	--	15.12	6.69	9.45	1.73	5.51	--	1.06	4-M16
4" x 3"	2.91	3.94	18.11	6.69	9.45	1.73	5.51	--	1.06	4-M16
4"	3.94	--	18.11	7.91	11.57	1.97	5.51	1.75	0.55	4-Ø23
6" x 4"	3.94	5.91	24.13	7.91	11.57	1.97	6.50	1.75	0.55	4-Ø23
6"	5.91	--	24.13	11.81	14.41	1.97	6.50	1.75	0.55	4-Ø23
8" x 6"	5.91	7.91	29.13	11.81	14.41	1.97	6.50	1.75	0.55	4-Ø23
8"	7.91	--	29.13	12.20	16.42	2.52	10.00	2.28	0.71	8-Ø19
8" x 10"	7.91	9.92	33.11	12.20	16.42	2.52	10.00	2.28	0.71	8-Ø19

9400 Series Top Entry Valve

DIMENSIONS - ANSI CLASS 1500 (INCHES)

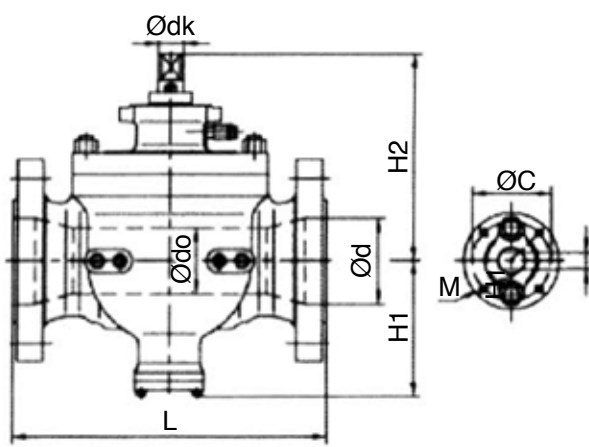

Size 2" ~ 3" (1500)

Size 2" (2500)

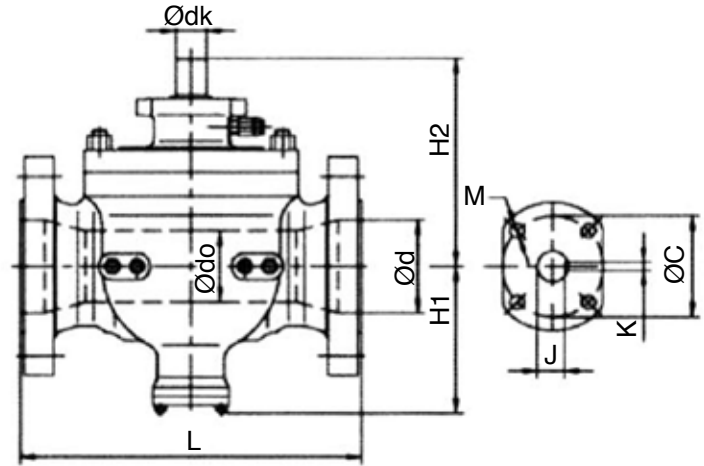

Size 4" ~ 6" (1500)

Size 3" ~ 6" (2500)

Valve Size	Ødo	Ød	L (RTJ)	H1	H2	Ødk	ØC	J	K	M
2"	1.93	--	14.61	6.42	8.70	1.34	4.02	--	0.87	4-M10
3" x 2"	1.93	2.91	18.62	6.42	8.70	1.34	4.02	--	0.87	4-M10
3"	2.91	--	18.62	7.87	11.69	1.97	6.50	1.75	0.55	4-Ø23
4" x 3"	2.91	3.94	21.61	7.87	11.69	1.97	6.50	1.75	0.55	4-Ø23
4"	3.94	--	21.61	9.72	12.99	1.97	6.50	1.75	0.55	4-Ø23
6" x 4"	3.94	5.67	27.99	9.72	12.99	1.97	6.50	1.75	0.55	4-Ø23
6"	5.67	--	27.99	12.95	16.30	2.52	10.00	2.28	0.71	8-Ø19
8" x 6"	5.67	7.56	33.11	12.95	16.30	2.52	10.00	2.28	0.71	8-Ø19

DIMENSIONS - ANSI CLASS 2500 (INCHES)

Valve Size	Ødo	Ød	L (RTJ)	H1	H2	Ødk	ØC	J	K	M
2"	1.93	--	14.61	6.42	8.70	1.34	4.02	--	0.87	4-M10
3" x 2"	1.93	2.91	15.12	6.42	8.70	1.34	4.02	--	0.87	4-M10
3"	2.91	--	15.12	6.69	9.45	1.73	5.51	--	1.06	4-Ø23
4" x 3"	2.91	3.94	18.11	6.69	9.45	1.73	5.51	--	1.06	4-Ø23
4"	3.94	--	18.11	7.91	11.57	1.97	5.51	1.75	0.55	4-Ø23
6" x 4"	3.94	5.91	24.13	7.91	11.57	1.97	6.50	1.75	0.55	4-Ø23
6"	5.91	--	24.13	11.81	14.41	1.97	6.50	1.75	0.55	4-Ø23
8" x 6"	5.91	7.91	29.13	11.81	14.41	1.97	6.50	1.75	0.55	4-Ø23

9400 Series Top Entry Valve

DIMENSIONS - ANSI 150 FULL PORT (INCHES)

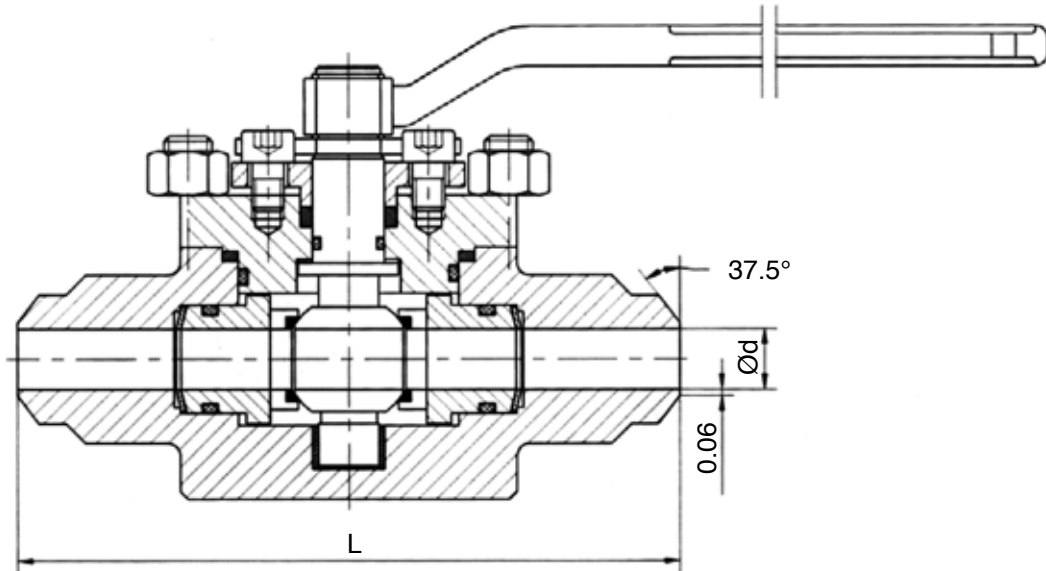

Valve Size	Ød	L
1/2"	0.59	6.50
3/4"	0.79	7.48
1"	0.98	8.50
2"	1.93	11.50

Parts	Materials
Body	ASME A182 F316L
Cap	ASME A182 F316L
Ball	ASME A182 F316
Seat	UHMWPE
Stem	ASME A182 F316
Springs	17-4PH
Packing	UHMWPE
Gaskets	SS304 + Graphite spiral wound gaskets
O-Ring	UHMWPE
Bolts/Nuts	B8M/8M

SPECIFICATIONS

- Designed to ASME B16.34
- BW end to ASME B16.25
- Face to face dimension to factory standard
- Blow-out proof stem

9400 Series Top Entry Valve

DIMENSIONS - 2" ANSI 1500 REDUCED PORT (INCHES)

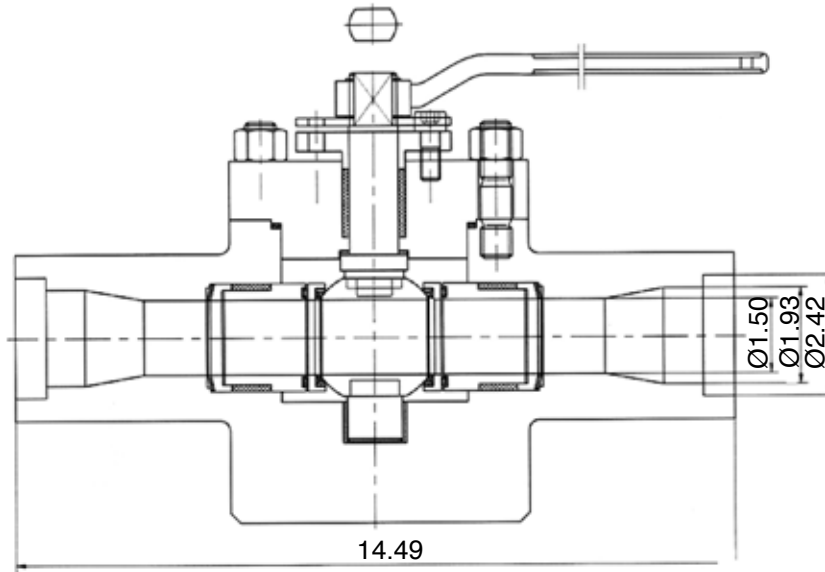

Parts	Materials
Body	LF2
Cap	LF2
Ball	F316 Nitride hardening
Seat	F316 + Stellite
Stem	F316
Springs	17-4PH
Packing	Graphite
Gaskets	SS304 + Graphite
Bolts/Nuts	L77M

SPECIFICATIONS

- Test and inspection to FCI 70-2
- Face to face dimension to factory standard
-

9400 Series Top Entry Valve

DIMENSIONS - 1" ANSI 1500 REDUCED PORT (INCHES)

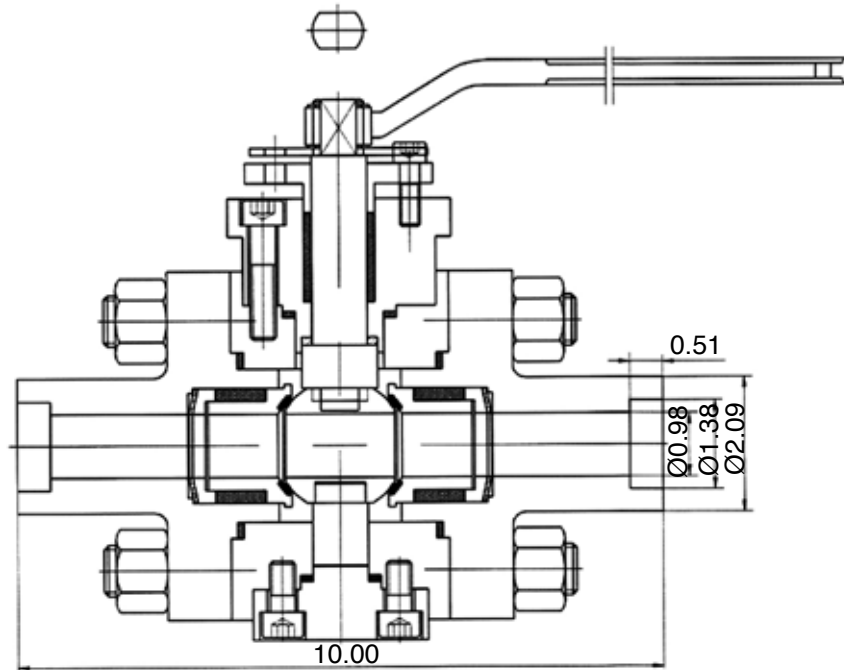

Parts	Materials
Body	LF2
Cap	LF2
Ball	F316 Nitride hardening
Seat	F316 + Stellite
Stem	F316
Springs	17-4PH
Packing	Graphite
Gaskets	SS304 + Graphite
Bolts/Nuts	L77M

SPECIFICATIONS

- Test and inspection to FCI 70-2
- Face to face dimension to factory standard
-

9400 Series Top Entry Valve

DIMENSIONS - 1-1/2" ANSI 600 FULL PORT (INCHES)

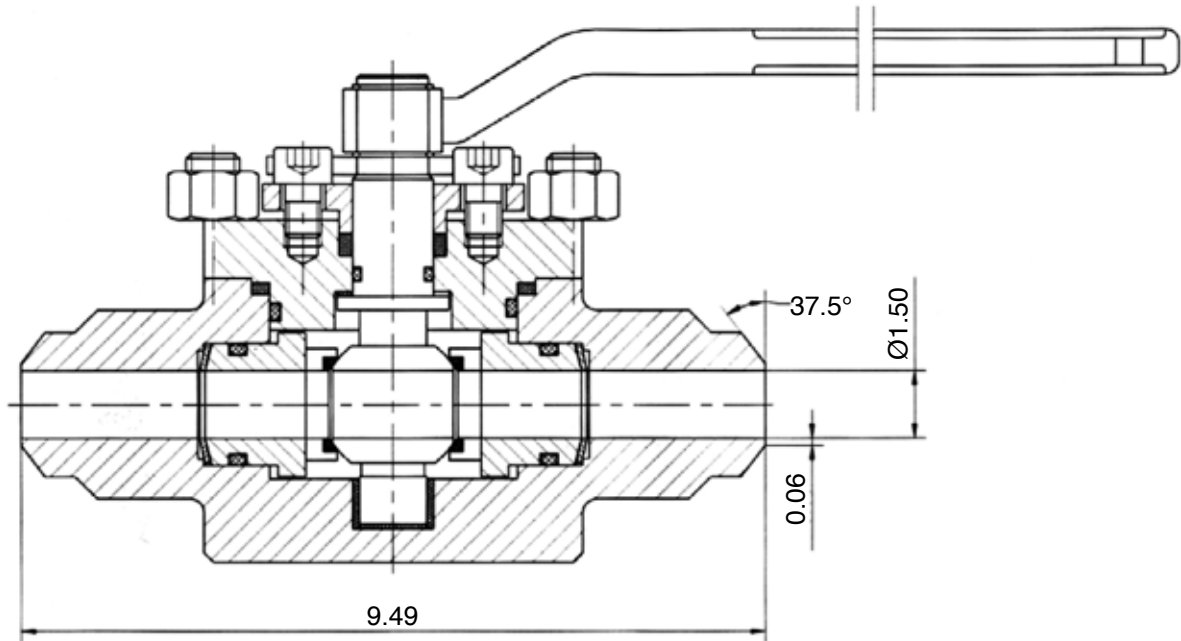

Parts	Materials
Body	ASME A182 F316L
Cap	ASME A182 F316L
Ball	ASME A182 F316
Seat	RPTFE
Stem	ASME A182 F316
Springs	17-4PH
Packing	Graphoil
Gaskets	SS304 + Graphite spiral wound gaskets
O-Ring	Viton
Bolts/Nuts	B8M/8M

SPECIFICATIONS

- Designed to ASME B16.34
- Test and inspection to ASME B16.25
- Face to face dimension to factory standard
- Blow-out proof stem

9400 Series Top Entry Valve

DIMENSIONS - 3/4" ANSI 1500 REDUCED PORT (INCHES)

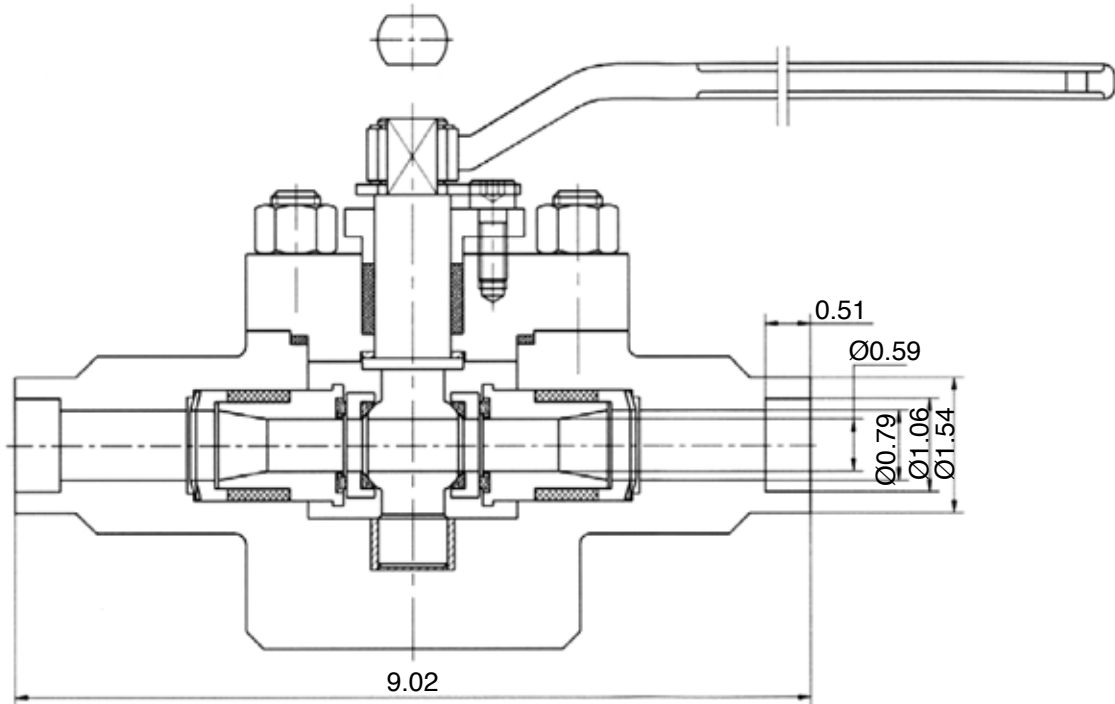

Parts	Materials
Body	LF2
Cap	LF2
Ball/Stem	F316 Nitride hardening
Seat	F316 + Stellite
Springs	17-4PH
Packing	Graphite
Gaskets	SS304 + Graphite
Bolts/Nuts	L77M

SPECIFICATIONS

- Test and inspection to FCI 70-2
- Face to face dimension to factory standard
-

9400 Series Top Entry Valves

TORQUE CHART (CLEAN SERVICE) TE-600 1/2" - 6"

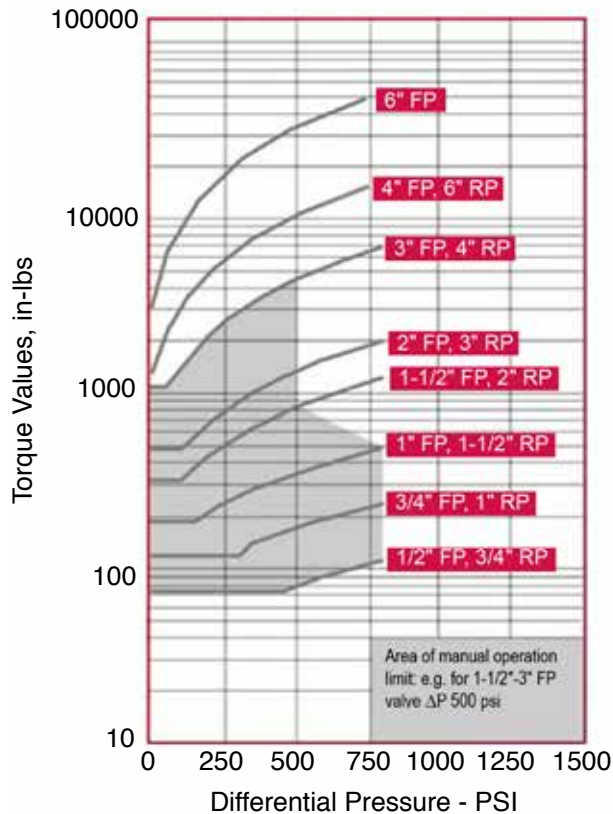

MAXIMUM DIFFERENTIAL PRESSURE TEMPERATURE RATINGS

- Stainless Steel (CF8M)

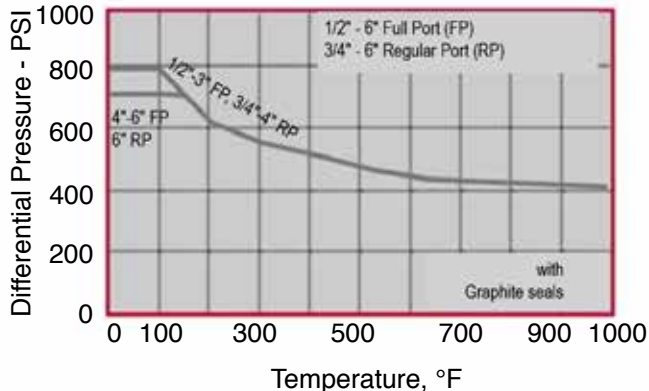

- Carbon Steel (WCB)

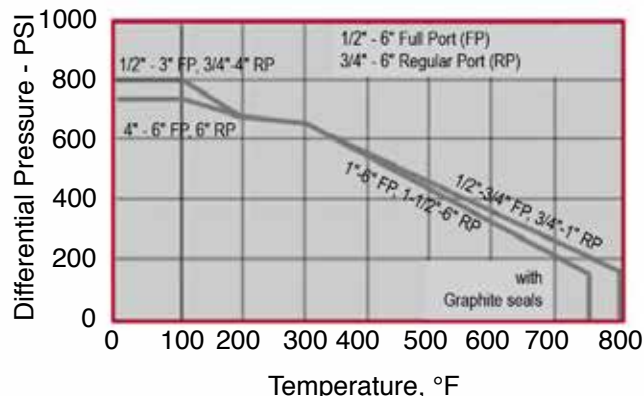

(1) Body rating is per B16.34 pressure/temperature ratings, except for 2" full port and 2" regular port, which are limited to 1200 psi at 100°F, 3" and larger full port and 4" and larger regular port are rated Class 300 only. Shutoff pressure for valves is limited to the differential pressure as shown on the graphs.
 (2) For full B16.34 ratings and/or shutoff against full B16.34 differential pressures consult factory.

HOW TO ORDER

Sizes	Series	Body ¹ , Ball & Stem	Port	Packing	Seat	End Connection	Options
3 1/2"	94	00 CF8	F Full	T TFM1600	6 Carbon PEEK	B1 BW10	BS Bare Stem
4 3/4"		0L CF3	R Red.	G Graphite	K Kel-F	B4 BW40	GO Gear Operator
5 1"		11 LF5			M Metal Stellite+316	B8 BS80	FS Fire Safe
0 1-1/4"		23 WCB, CF8M Ball & Stem			N Nylon	S Socket Weld	SE Stem Extension
6 1-1/2"		33 CF8M			P PEEK	FF Flat Face	
7 2"		44 Alloy 20			R Reinforced	F1 ANSI 150	
8 3"		55 Monel			T TFM1600	FF Flat Face	
9 4"		6L CF3M				F1 ANSI 150	
A 6"		77 Hastelloy C				F3 ANSI 300	
B 8"		88 LF2/LCB 17-4 Stem				F6 ANSI 600	
C 10"		83 LCB, CF8M Ball & Stem				F9 ANSI 900	
D 12"		99 Duplex				F5 ANSI 1500	
E 14"		AA A105 with Chrome					
F 16"		AB A105, AISI 410 trim					
G 18"		EE A105 with Electroless Nickel Ball & Stem					
H 20"							

¹ Please see the J Flow Controls Configurator for a full list of body materials