



# SERIES 4000

## BALANCE TYPE GLOBE CONTROL VALVE

COMPREHENSIVE RANGE  
OF VALVES FOR THE  
ENERGY & PROCESS  
INDUSTRIES

4665 Interstate Drive Cincinnati, OH

45246 513-731-2900

[jflowcontrols.com](http://jflowcontrols.com)

**CONTENTS**

---

FEATURES	03
BODY STYLE	04
BONNET STYLE	04
TRIM DESIGNS	05
RATED C <sub>v</sub> VALUE AND STROKE	06
FLOW CHARACTERISTICS	07
SPECIFICATION	10
SELECTION GUIDELINE	12
MATERIALS OF CONSTRUCTION	14
DIMENSIONS	19
NUMBERING SYSTEM	22

## MAIN PRODUCT FEATURE

- The large stroke and complete guiding enhances the stability of plug under large pressure, reduces side load and plug vibration, and prolongs the service life of valve.
- The standardized and modularized design makes the performance more reliable.
- The piston ring and high performance seal ring are used for sealing so as to enhance the leakage level.
- The packing box adopts maintenance-free self-tightening sealing design, which is more safe and more reliable.
- The packing box system is additionally provided with dust cover to effectively prevent dust and particles from entering into the packing box.
- The body is completely interchangeable with that of single seat valve, and the online replacement of valve trims can be realized.
- The pressure containing parts are designed in accordance with ASME nuclear power level standard, with more safe use and being more applicable to severe working conditions.

## 4000 SERIES CAGE GUIDED CONTROL VALVE

- 4000 Series cage control valve is a high performance pressure balancing control valve produced by our company through advanced technology. In this series valve, the structure of body is compact, the plug guiding system through cage with anti-vibration performance, and the high performance seal ring are adopted for sealing so as to enhance the leakage level. It has such features as small volume, light weight, low pressure drop loss, large flow, wide rangeability, high precision flow characteristic curve, good dynamic stability, low noise, low cavitation corrosion and small leakage. This series of products can be widely used in the applications where the allowable pressure drops is relatively higher.
- The control valve is coupled with our new generation high performance actuator as a standard. With compact structure and large output force, it is suitable for controlling various media of different pressures and temperatures.



## BODY STYLES



### Globe Valve

Globe style bodies feature smooth, streamlined, constant -area internal passages with no pockets, permitting high capacity with minimum turbulence. They are designed with very constant wall thickness, providing lower weight and cost when manufactured in expensive stainless or alloy steels.

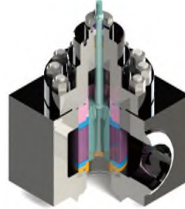

### Angle Valve

Except for the body, the angle-style valve is completely interchangeable with the globe style-all other valve parts remain the same. For additional body protection, extensions to the outlet flange, is available.



### Jacket Valve

The jacket valve uses a standard globe body with oversized, blind flanges for a full jacket of standard flanges for a partial jacket. The jacket is equipped with drain connection.

## BONNET STYLES

Standard bonnet - enables the forming of a deep packing box, together with a longer guide. Providing a robust and vibration resistant assembly. TFM1600 rings are used in the standard packing up to 480F (250C).

Extended bonnet - protects the packing from excessive temperature variables, both hot and cold, which may adversely affect valve and packing performance. Application temperature range depends upon valve and bonnet construction materials.



STANDARD BONNET

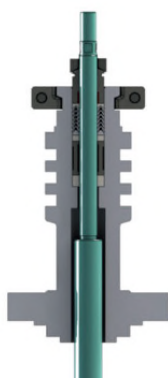

EXTENSION BONNET



BELLOWS BONNET



CRYOGENIC BONNET

**Bellows Bonnet**- provides for a positive metallic gland seal within the rated pressure and temperature of the bellows material selected. This bonnet is used for hazardous, lethal service with auxiliary packing box in the upper bonnet to serve as a back up seal.

**Extension Bonnet**- protects the packing from the extremes of temperature changes produced by the line process media. Normal constructed in Stainless Steel to operate in cold applications to -320F (-196C). Higher Temperatures in varying materials to 1562F (850C)

## TRIM DESIGNS

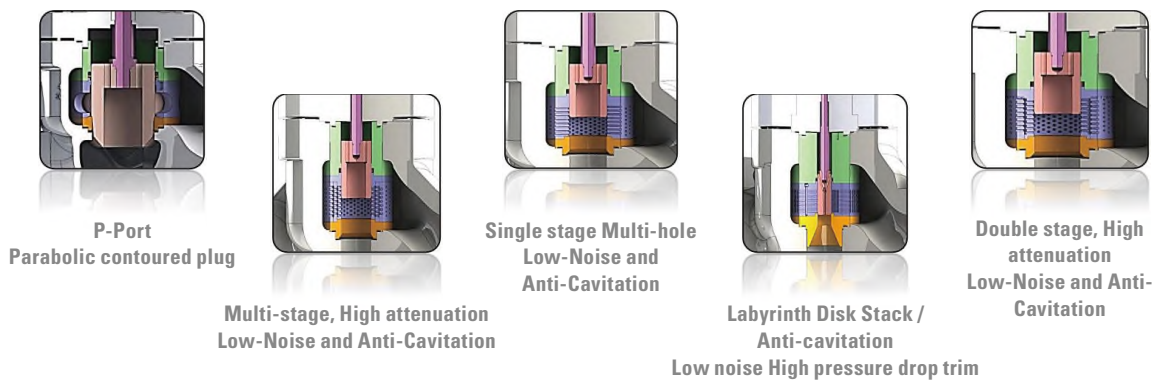

### Performance

- High Flow Capacity
- Tight Shutoff
- Stable Operation
- Excellent Flow Control Rangeability

### Design Flexibility

- Inherently characterized trim offered in equal %, linear and quick opening.
- Multi trim size available.
- Full rationalized and interchangeable features.

### Design Integrity

- Quick changed trim for easy maintenance.
- Large diameter stems for stable operation.
- Heavy duty top guiding with no bottom guide to obstruct seat bore and potentially trap debris.

### Various Trim Options

- Designed to handle high pressure drops in severe service applications for incompressible fluids. Complete cavitation protection is available for pressure drops up to 3000 psi.
- Tighter shutoff capability at high operating temperatures is achievable using a spring-loaded internal auxiliary plug construction. An optional downstream diffuser is also available for additional noise reduction.
- Designed for noise control on gas or steam at high pressure drop ratios. Also available for anti-cavitation on high pressure liquid applications.

**RATED CV VALUE AND STROKE**

Trim Size (Inches)	Stroke (mm)	Cage (Window)			1-Stage Drilled Hole		2-Stage Drilled Hole		3-Stage Drilled Hole	
		Quick Opening	Linear	EQ-%	Linear	EQ-%	Linear	EQ-%	Linear	EQ-%
5/32"	10	0.4	0.3							
1/4"	20	1	0.8							
3/8"	20	2.3	1.8							
1/2"	20	4	3.2							
5/8"	20	6	5.2		5.2	5.2	5.2	5.2	5.2	5.2
3/4"	20	9	7		7	7	7	7	7	6
1"	20	16	12		12	12	10	9	9	8
1-1/4"	20	25	20		20	17				
	30						20	17	18	16
1-1/2"	20	33	28		26	22				
	30						25	21	22	20
2"	30	60	50		48	42				
	40						44	38	40	35
2-1/2"	30	80	70		66	58				
	40						75	60	70	55
3"	40	132	110		100	90	90	70	75	60
4"	40	210	180	160	150	130	120	94	110	90
5"	60	320	300	280	270	230	230	180	210	160
6"	60	430	400	360	340	290	280	210	250	190
7"	80	660	580	520	500	430	430	330	400	300
8"	80	860	720	640	600	520				
	90						540	420	500	380
9"	90	1000	900	800	780	600				
	100						690	540	640	490
10"	100	1400	1200	1100	940	800	780	600	720	540
12"	120	1900	1600	1400	1400	1200	1100	850	1000	760
14"	150	2760	2300	2000	1900	1700	1600	1300	1400	1100
16"	150	3300	2800	2400	2300	2000	1900	1500	1700	1300
18"	200	4560	3800	3400	3300	2800	2700	2200	2500	2000

**Note!**  
Trim size is variable per class rating.

# FLOW CHARACTERISTICS

The flow characteristic describes the relationship between the flow coefficient and the valve stroke. It is inherent to the design of the selected valve. For example, as the valve is opened, the flow characteristic allows a certain amount of flow through the valve at a particular percentage of the stroke. This is especially important for throttle control because it controls the flow in a predictable manner. The flow rate is affected by the flow characteristic as well as the pressure drop. Inherent flow characteristic is when the valve is operating with a constant pressure drop without taking into account the effects of piping. Installed flow characteristics consider both the valve and piping effects. This is also considered an ideal curve and takes the entire system into account.

## Equal Percentage

Equal percentage is the characteristic most commonly used in process control. The change in flow per unit of valve stroke is directly proportional to the flow occurring just before the change is made. While the flow characteristic of the valve itself may be equal percentage, most control loops will produce an installed characteristic approaching linear when the overall system pressure drop is large relative to that across the valve.

## Linear

An inherently linear characteristic produces equal changes in flow per unit of valve stroke regardless of plug position. Linear plugs are used on those systems where the valve pressure drop is a major portion of the total system pressure drop.

## Quick-opening

Quick opening flow is characterized by the maximum flow produced immediately as the valve begins to open. It is only used for on-off applications and due to the extreme nature of the flow, the inherent and installed characteristics are similar.

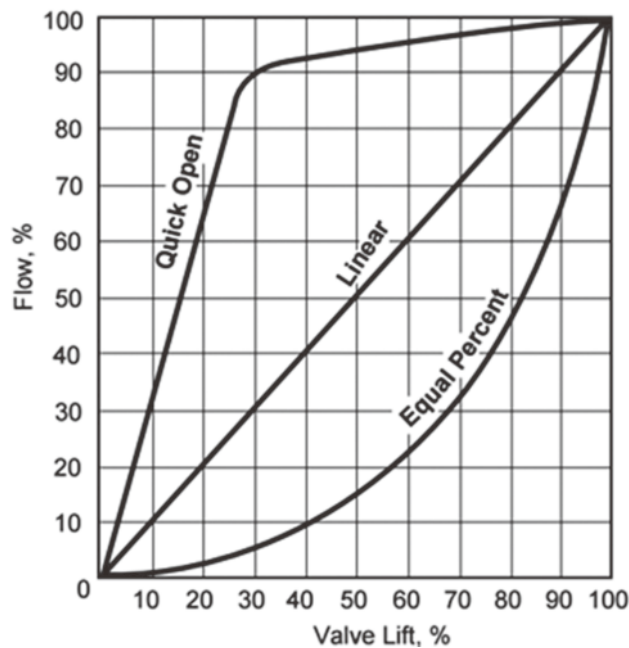

Inherent Flow Curves for Various Valve Plugs

# DISK STACK TRIM APPLICATIONS

## Severe Service Power Plant

- Main & Start-up feed pump recirculation
- Main & Booster feed water recirculation
- Condensate booster pump recirculation
- Deaerator level control
- Turbine by-pass steam generator blow down
- Auxiliary steam shoot blower control
- Boiler start-up main steam spray
- Pressurizer PORV/CVCS letdown
- HP coolant injection
- Atmospheric steam dump
- Atmospheric venting silencer

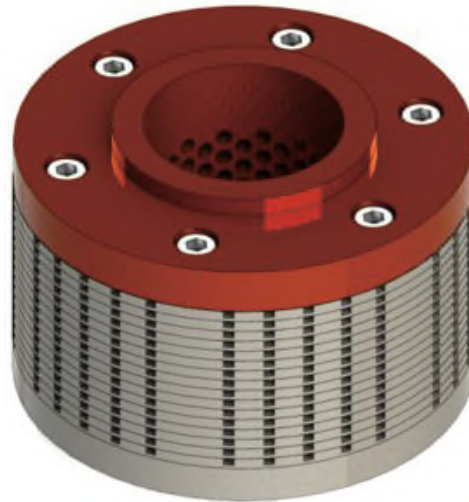

## Severe Service Power Plant

- Compressor recycle & Anti-surge / kick back
- Pump minimum flow & Recirculation
- Blow down discharge to vent flare
- Reactor depressurization
- Turbo expander by-pass
- Gas injection lift control
- Gas storage pressure letdown
- Gas flow regulation
- Pipeline anti-surge
- Heavy oil letdown
- Ethylene letdown
- Steam vent to atmosphere
- Gas choke valves

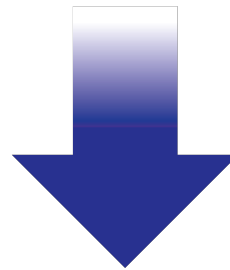

## Severe Service Power Plant

- Prolonged trim life
- Eliminates downtime
- Effective noise control
- Reduction of pipe fatigue
- Flexible characterization
- Control valve vibration
- Reduced maintenance cost.
- Faster start-up

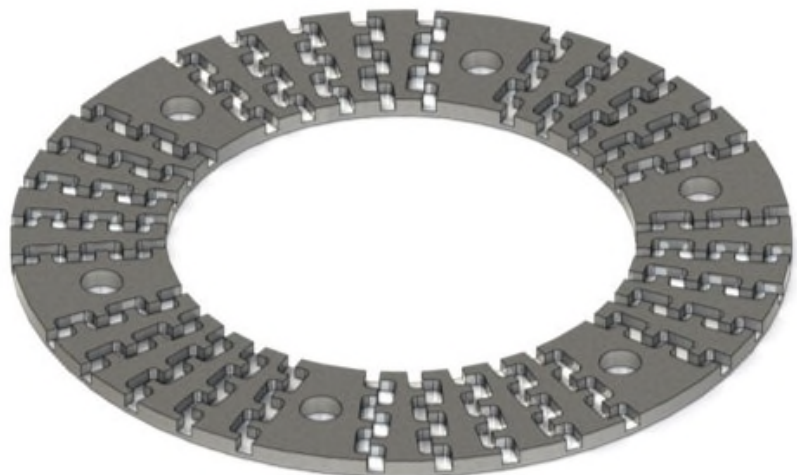



# DISK STACK TRIM

## Disk Stack

The disk stack incorporates a unique advanced design that is super at limiting flowing velocities to low levels resulting in valves providing service that is quiet, non cavitations and non erosive.

Disk stack low velocity is achieved through the use of a trim cage made by bonding together a series of individual disks. Each disk has a pattern of carefully controlled orifices and channels with a multitude of sharp turns etched into its surface. As the trim plug travels within the cage the fluid is throttled and forced to travel an extremely tortuous path with each turn effecting a stage of pressure drop.

The combined effect of numerous narrow flow channels, each with many sharp turns and a continually expanding flow path, removes kinetic energy from the fluid while gradually lowering its pressure. In doing so, abrupt velocity increases that are the source of noise are avoided. The additional benefit for liquid flow is the elimination of cavitations and the damage it can do a valve, its trim and the down stream piping.

By its very design, Disk stack allows for many more stages of drop than conventional tortuous path times. Resolves existing problems for both compressible and incompressible fluid flow applications.

### Technology benefits

- Increased plant production
- Reduced maintenance costs
- Elimination of damage from cavitation, noise and pipe vibration
- Prolonged trim life
- Custom engineered valve designs to fit your piping construction.
- Simpler trim maintenance ; it's the trim structure of stack type and can be disassembled completely.

Therefore it can be replaced easily when a partial is damaged on the stack occurs.

Disk Stack Trim technology is recognized as the optimum severe service solution available today, and is custom engineered to solve severe service problems.

Pressure Drop & Velocity Change Profile Through The Valve

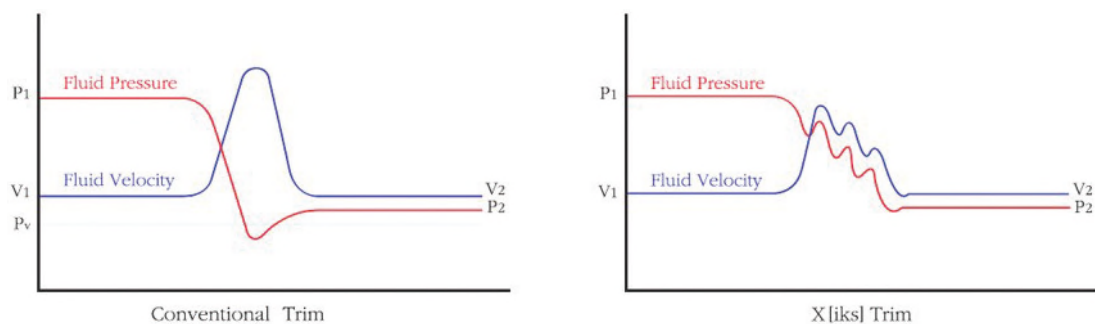

# GENERAL BODY SPECIFICATION

<b>BODY TYPE</b>	Through Way (2 Way Globe)
<b>BONNET</b>	Plain (Standard), Fin & Extension, Bellows Seal Long Extension (Cryogenic Service)
<b>SIZE RANGE</b>	1 1/2" to 32"(DN40...DN800) Option : Larger than 32 inches
<b>PRESSURE RATING</b>	ANSI 150LBS to 2500LBS (Option : 4500LBS) JIS 10K to 180K PN20 to PN420
<b>OPERATING PRESSURE RANGE</b>	Up to 6,171psi (g) Up to 434 Kg/cm <sup>2</sup> (g)
<b>OPERATING TEMPERATURE RANGE</b>	-58°F to +1,050°F -50°C to +565°C Option : -320°F to +1,562°F, -192°C to +850°C
<b>END CONNECTION</b>	Socket Weld – ANSI B16.11 Butt Weld – ANSI B 16.25 FF/RF/RTJ Flange – ANSI B 16.5 Option : JIS Flange, DIN Flange, NPT/PT Screw
<b>MATERIAL</b>	Carbon Steel (WCB, WCC, A105) Chrome-moly Steel(WC6, WC9, C12A, F11, F22, F91) Stainless Steel (CF8, CF8M, CF3, CF3M, F304, F304L, F310, F316L) Duplex Stainless Steel, Monel, AL Bronze, Inconel 625 Hastelloy B/C, Other Alloy
<b>ACTUATOR</b>	Pneumatic Diaphragm Pneumatic Cylinder Electric Motorized Electric Hydraulic

# STANDARD TRIM SPECIFICATION

## Balanced Plug Type Quick Change Trim

<b>SIZE RANGE</b>	1-1/2" to 32"
<b>TRIM TYPE</b>	P-Port (Parabolic Contoured Plug) Cage Window Low-Noise Drilled Hole Cage (1/2/3-Stage) Anti-Cavitation Channel Cage (1/2/3-Stage) Labyrinth Disk Stack Hybrid Trim (Disk Stack + Drill Hole Cage)
<b>PLUG GUIDE METHOD</b>	Cage Guide
<b>FLOW DIRECTION</b>	Gas, Steam : Flow to Open Liquid : Flow to Close (* Note)
<b>Cv RANGE</b>	12 to 6800
<b>FLOW CHARACTERISTIC</b>	Linear, Equal %, Modified Equal %, Quick Open
<b>SEAT LEAKAGE</b>	FCI-70.2 Standard : ANSI Class IV Option : ANSI Class V ANSI Class VI (Soft Seat) MSS-SP61 (On-Off)
<b>MATERIAL</b>	316 SS, 316 SS + Stellite #6 Hardness 410 SS/ 400C SS 17-4PH, F22 (Nitride treatment), F51 Inconel 718, XM19 Solid Tungsten Carbide Etc.

**Note!**

Flow Direction can be changed according to your specifications.

# SPECIAL SPECIFICATION

<b>SPECIAL SPECIFICATIONS</b>	Material Certificate, Characteristics Testing, Radiation Testing(RT) Liquid Penetration Testing (PT), Low Temperature Testing
<b>SPECIAL REQUIREMENTS</b>	Oxygen Clean, Copper-Free Alloy. Water-Free Special Piping and Fitting, Salty Environment Proof Cold Area Proof, Tropical Area Proof, Non-standard Painting.

# SELECTION GUIDELINE

## VELOCITY LIMITATIONS

In selecting a valve for either a liquid or gas/vapor application one of the major considerations is the effect of fluid velocity. High velocity could lead to operational problems including erosion, excessive vibration and instability. The following tables indicate the maximum recommended velocity values for liquid and gas/vapour services.

### Recommended Maximum Velocities for Liquid Flow

Trim Design	Valve Size		Carbon Steel		Alloy Steel		Bronze	
	Size	in	mm	ft / sec	m / sec	ft / sec	m / sec	ft / sec
Microflow	0.5 to 1	15 to 25	43	13.1	52	15.8	26	7.6
Contoured	0.5 to 2	12 to 50	41	12.5	46	14	25	7.6
	2.5 to 6	65 to 150	34	10.4	34	10.4	20	6.2
	8 to 14	200 to 350	29	8.9	29	8.9	17	5.2
	16 to 18	400 to 450	22	6.7	22	6.7	13	4
	20	500	18	5.5	18	5.5	11	3.4
	24	600	12	3.7	12	3.7	7	2.1
Hard Facing	0.5 to 12	15 to 300	43	13.1	52	15.8	26	7.6
	14 to 500	350 to 500	35	10.7	43	13.1	21	6.4
	24	600	25	7.6	35	10.7	15	4.6

### Recommended Maximum Velocities for Gas / Vapor Flow

Trim Design	Valve Size		Maximum Inlet		Maximum Outlet		Maximum Out Mach. No. for Required Noise Level		
	Size	in	mm	ft / sec	m / sec	ft / sec	m / sec	>95dBA	<95dBA
Microflow	0.5 to 1	15 to 25	475	144	830	253	0.65	0.5	0.3
Contoured	0.5 to 2	12 to 50	340	104	830	253	0.65	0.5	0.3
	2.5 to 6	65 to 150	295	90	830	253	0.65	0.5	0.3
	8 to 14	200 to 350	265	81	830	253	0.65	0.5	0.3
	16 to 18	400 to 450	190	58	830	253	0.65	0.5	0.3
	20	500	150	46	830	253	0.65	0.5	0.3
	24	600	115	35	830	253	0.65	0.5	0.3
Hard Facing	0.5 to 24	15 to 600	475	144	830	253	0.65	0.5	0.3

## Contoured Trim

Valve Size		Body Rating	Seat Type	Packing Material	Temperature Range				Seat Leakage IEC 60534-4 and FCI 70-2 Class		
					Standard Bonnet		Extension Bonnet		Cryogenic Bonnet		Standard
in	mm				min.	max.	min.	max.	min.	max.	
0.5 to 8	15 to 200	ANSI 150 to 600 LBs and Equivalent JIS, PN	Metal	PTFE Aramid	-20°F (-29°C)	+450°F (+232°C)	-100°F (-73°C)	+800°F (+427°C)			
				Graphite	-20°F (-29°C)	+800°F (+427°C)	-100°F (-73°C)	+800°F (+427°C)	IV	V	
				V-PTFE					-320°F (-196°C)	+450°F (+232°C)	
			Soft	PTFE Aramid	-20°F (-29°C)	+450°F (+232°C)	-100°F (-73°C)	+450°F (+232°C)			VI

## Low- Noise / Anti-Cavitation Trim

Valve Size		Body Rating	Seat Type	Packing Material	Temperature Range				Seat Leakage IEC 60534-4 and FCI 70-2 Class	
					Standard Bonnet		Extension Bonnet		Cryogenic Bonnet	
in	mm				min.	max.	min.	max.	min.	max.
0.5 to 8	15 to 200	ANSI 150 to 600 LBs and Equivalent JIS, PN	Metal	PTFE Aramid	-20°F (-29°C)	+450°F (+232°C)	-100°F (-73°C)	+800°F (+427°C)		
				Graphite	-20°F (-29°C)	+800°F (+427°C)	-100°F (-73°C)	+800°F (+427°C)	IV	V
				V-PTFE					-320°F (-196°C)	+450°F (+232°C)

- ANSI 900-1500LBs available only in 0.5 to 4 inch (15 to 100 mm) sizes.  
ANSI 2500LBs available only in 0.5 to 2 inch (15 to 50 mm) sizes.
- See Materials of Construction Tables for other temperature limitations.
- 2-Stage design only available with Quick Change seat rings.
- 2-Stage Anti-Cavitation Trim not available in 6 inch (150 mm) and 8 inch (200 mm) size.
- PTFE Aramid Inorganic Coil Packing for low emissions applications is limited to maximum pressure and temperature as shown in the chart below.
- Soft seat is limited to a maximum of 1000 psi (70 bar) pressure drop and a maximum of 450°F (232°C).

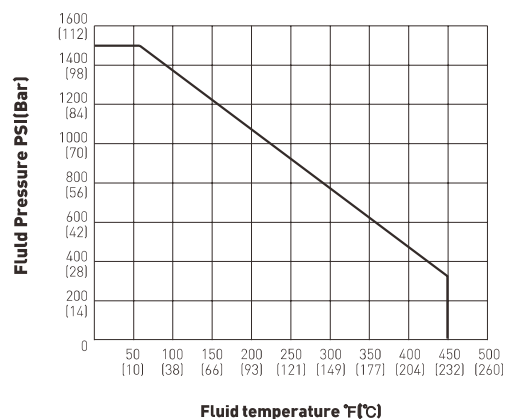

Pressure and Temperature Rating of LE Packing

# MATERIALS OF CONSTRUCTION

## STANDARD CARBON STEEL VERSION

Part No.	Temperature Range	-20°F (-29°C)	450°F (232°C)	650°F (343°C)	800°F (427°C)
		▼	▼	▼	▼
Description		Standard Materials			
1	Body	A216 Gr. WCB			
2	Bonnet	A216 Gr. WCB			
3	Seat Ring	304 Stainless Steel			
		410 Stainless Steel + Heat Treatment			
		304 Stainless Steel + Stellite #6 Hard Facing			
4	Plug/Disc	304 Stainless Steel			
		410 Stainless Steel + Heat Treatment			
		304 Stainless Steel + Stellite #6 Hard Facing			
5	Valve Stem	304 Stainless Steel			
		410 Stainless Steel + Heat Treatment			
		17-4PH (630) Stainless Steel			
6	Cage	304 Stainless Steel			
		410 Stainless Steel + Heat Treatment			
7	Guide Bushing	410 Stainless Steel + Heat Treatment			
		304 Stainless Steel + Stellite #6 Hard Facing			
8	Body Gasket	316 Stainless Steel+Graphite -Spiral Wound			
		316 S.S. +Teflon -Spiral Wound			
9	Seat Gasket	316 Stainless Steel+Graphite -Spiral Wound			
		316 S.S. +Teflon -Spiral Wound			
10	Paug Pin	316 Stainless Steel			
11	Packing	V-PTFE		Graphite	
		PTFE Aramid Inorganic Coil			
12	Lantern Ring	304 Stainless Steel			
13	Packing Gland	304 Stainless Steel			
14	Packing Flange	304 Stainless Steel			
15	Body Stud Bolt	A193 Grade B7			
16	Body Stud Nut	A194 Grade 2H			
17	Packing Stud Bolt	A193 Grade B8			
18	Packing Stud Nut	A194 Grade 8			
19	Yoke Half Clamp	304 Stainless Steel			
20	Clamp Hex. Bolt	A193 Grade B8			
21	Clamp Hex. Nut	A194 Grade 8			

1. 17-4 PH ST.ST will be substituted when required due to the differential pressure.
2. 410 SS bushing not used in combination with 316 SS trim.
3. Standard material for two stage lo-db (drilled hole) cages.
4. Required for Quick Change trim only.
5. Use Solid Stellite plug for Cv smaller than 1.7.
6. Guide bushings not used with close clearance trim.
7. Solid Stellite is not available for Low-Noise/Anti-Cavitation plugs.

## STANDARD STAINLESS STEEL VERSION

Part No.	Temperature Range	-20°F (-29°C)	450°F (232°C)	650°F (343°C)	800°F (427°C)
		▼	▼	▼	▼
Description		Standard Materials			
1	Body	A351 Gr. CF8M			
2	Bonnet	A351 Gr. CF8M			
3	Seat Ring	316 Stainless Steel			
		316 Stainless Steel + Stellite #6 Hard Facing			
4	Plug/Disc	316 Stainless Steel			
		316 Stainless Steel + Stellite #6 Hard Facing			
5	Valve Stem	316 Stainless Steel			
		17-4PH(630) Stainless Steel			
6	Cage	316 Stainless Steel			
7	Guide Bushing	316 Stainless Steel + Stellite #6 Hard Facing			
8	Body Gasket	316 Stainless Steel+Graphite -Sprial Wound			
		316 S.S. + Teflon -Sprial Wound			
9	Seat Gasket	316 Stainless Steel+Graphite -Sprial Wound			
		316 S.S. +Teflon -Sprial Wound			
10	Paug Pin	316 Stainless Steel			
11	Packing	V-PTFE		Graphite	
		PTFE Aramid Inorganic Coil			
12	Lantern Ring	316 Stainless Steel			
13	Packing Gland	316 Stainless Steel			
14	Packing Flange	316 Stainless Steel			
15	Body Stud Bolt	A193 Grade B8			
16	Body Stud Nut	A194 Grade 8			
17	Packing Stud Bolt	A193 Grade B8			
18	Packing Stud Nut	A194 Grade 8			
19	Yoke Half Clamp	304 Stainless Steel			
20	Clamp Hex. Bolt	A193 Grade B8			
21	Clamp Hex. Nut	A194 Grade 8			

1. Required for Quick Change trim only.
2. Standard material for two stage lo-db (drilled hole) cages.
3. Use Solid Stellite plug for Cv smaller than 1.7.
4. Guide bushings not used with close clearance trim.
5. Solid Stellite is not available for Low-Noise/Anti-Cavitation plugs.

**STANDARD CHROME MOLY VERSION**

Part No.	Temperature Range	-20°F (-29°C)	450°F (232°C)	650°F (343°C)	800°F (427°C)
		▼	▼	▼	▼
Description		Standard Materials			
1	Body	A217 Gr. WC9			
2	Bonnet	A217 Gr. WC9			
3	Seat Ring	304 Stainless Steel			
		410 Stainless Steel + Heat Treatment			
		304 Stainless Steel + Stellite #6 Hard Facing			
4	Plug/Disc	304 Stainless Steel			
		410 Stainless Steel + Heat Treatment			
		304 Stainless Steel + Stellite #6 Hard Facing			
5	Valve Stem	304 Stainless Steel			
		410 Stainless Steel + Heat Treatment			
		17-4PH (630) Stainless Steel			
6	Cage	304 Stainless Steel			
		410 Stainless Steel + Heat Treatment			
7	Guide Bushing	410 Stainless Steel + Heat Treatment			
		304 Stainless Steel + Stellite #6 Hard Facing			
8	Body Gasket	316 Stainless Steel+Graphite -Spiral Wound			
		316 S.S. +Teflon -Spiral Wound			
9	Seat Gasket	316 Stainless Steel+Graphite -Spiral Wound			
		316 S.S. +Teflon -Spiral Wound			
10	Paug Pin	316 Stainless Steel			
11	Packing	V-PTFE		Graphite	
		PTFE Aramid Inorganic Coil			
12	Lantern Ring	304 Stainless Steel			
13	Packing Gland	304 Stainless Steel			
14	Packing Flange	304 Stainless Steel			
15	Body Stud Bolt	A193 Grade B7			
16	Body Stud Nut	A194 Grade 2H			
17	Packing Stud Bolt	A193 Grade B8			
18	Packing Stud Nut	A194 Grade 8			
19	Yoke Half Clamp	304 Stainless Steel			
20	Clamp Hex. Bolt	A193 Grade B8			
21	Clamp Hex. Nut	A194 Grade 8			

1. 17-4 PH ST.ST will be substituted when required due to the differential pressure.
2. Required for Quick Change trim only.
3. Standard material for two stage lo-db (drilled hole) cages.
4. Use Solid Stellite plug for Cv smaller than 1.7.
5. Guide bushings not used with close clearance trim.
6. Solid Stellite is not available for Low-Noise/Anti-Cavitation plugs.



## NACE MATERIALS CONSTRUCTION

Part No.	Temperature Range	-20°F (-29°C)	450°F (232°C)	650°F (343°C)	800°F (427°C)
		▼	▼	▼	▼
Description		Standard Materials			
1	Body	A351 Gr. CF8M			
2	Bonnet	A351 Gr. CF8M			
3	Seat Ring	316 Stainless Steel			
		316 Stainless Steel + Stellite #6 Hard Facing			
4	Plug/Disc	316 Stainless Steel			
		316 Stainless Steel + Stellite #6 Hard Facing			
5	Valve Stem	316 Stainless Steel			
6	Cage	316 Stainless Steel			
7	Guide Bushing	316 Stainless Steel + Stellite #6 Hard Facing			
8	Body Gasket	316 Stainless Steel+Graphite -Sprial Wound			
		316 S.S. + Teflon -Sprial Wound			
9	Seat Gasket	316 Stainless Steel+Graphite -Sprial Wound			
		316 S.S. +Teflon -Sprial Wound			
10	Paug Pin	316 Stainless Steel			
11	Packing	V-PTFE		Graphite	
		PTFE Aramid Inorganic Coil			
12	Lantern Ring	316 Stainless Steel			
13	Packing Gland	316 Stainless Steel			
14	Packing Flange	316 Stainless Steel			
15	Body Stud Bolt	A193 Grade B8			
16	Body Stud Nut	A194 Grade 8			
17	Packing Stud Bolt	A193 Grade B8			
18	Packing Stud Nut	A194 Grade 8			
19	Yoke Half Clamp	304 Stainless Steel			
20	Clamp Hex. Bolt	A193 Grade B8			
21	Clamp Hex. Nut	A194 Grade 8			

1. Materials and processes in accordance with the requirements of NACE specification MR 0103 Applications requiring compliance to MR 0175, 2003 Rev. or ISO 15156 would require engineering review.
2. Inconel 718 will be substituted in applications when required due to the differential pressure.
3. Materials designated for these parts conform to NACE Class III (unexposed) bolting requirements.
4. Materials designated for these parts conform to NACE Class I or Class II (exposed) bolting requirements.
5. Consult JFLOW for NACE Applications above ANSI Class 600 (PN 100) rating or above 450°F (232°C).
6. Optional component and materials for Close Clearance low flow trim option.
7. To be used with stainless steel body and bonnet.
8. Guide bushing not used with close clearance trim.
9. Solid Stellite is not available for Low-Noise/Anti-Cavitation plugs.

**The structure of the single seat control valve**

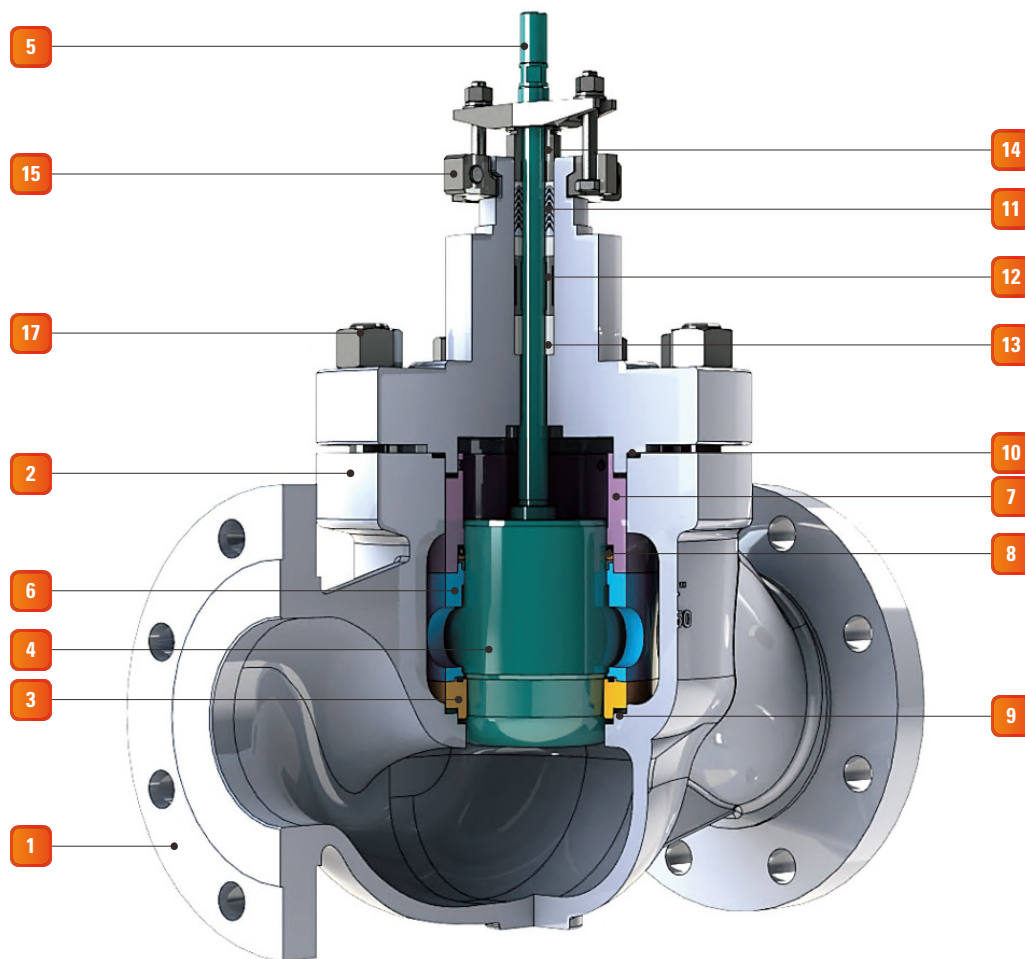

4000 Series Assembly Drawing

1	Valve Body	10	Body Gasket
2	Valve Bonnet	11	Packing
3	Seat Ring	12	Packing Spacer
4	Plug	13	Stem Guide
5	Stem	14	Packing Follower
6	Cage	15	Packing Flange
7	Balance Cylinder	16	Yoke Clamp
8	Balance Seal	17	Body Stud Bolt & Nut
9	Seat Ring Gasket		

# BODY DIMENSIONS (mm)

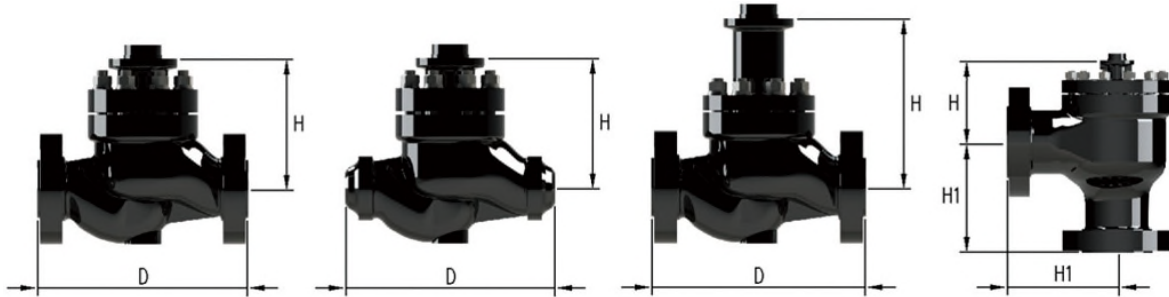

## ANSI Class 150 through 2500 and equivalent PN

Valve Size (inches)	" D "																			
	ANSI Class 150-300		ANSI Class 600		ANSI Class 900-1500		ANSI Class 2500		ANSI Class 150		ANSI Class 300		ANSI Class 600		ANSI Class 900		ANSI Class 1500		ANSI Class 2500	
	PN 20-50		PN 100		PN 150-250		PN 420		PN 20		PN 50		PN 100		PN 150		PN 250		PN 420	
	SW	BW	SW	BW	SW	BW	SW	BW	RF	RTJ	RF	RTJ	RF	RTJ	RF	RTJ	RF	RTJ	RF	RTJ
1/2	-	-	-	210	-	-	-	-	184	184	190	190	203	203	292	292	292	292	318	318
3/4	-	-	-	210	-	-	-	-	184	184	194	194	206	206	292	292	292	292	318	318
1	210	210	210	210	210	-	210	-	184	184	197	197	210	210	292	292	292	292	318	318
1-1/2	251	251	251	251	235	-	-	-	222	222	235	235	251	251	333	333	333	333	381	381
2	286	286	286	286	292	-	-	-	254	254	267	267	286	286	375	375	375	375	400	400
2-1/2	292	292	311	311	-	410	-	-	276	276	292	292	311	311	410	410	410	410	441	441
3	318	318	337	337	-	460	-	498	298	298	318	318	337	337	441	441	460	460	498	498
4	368	368	394	394	-	530	-	575	352	352	368	368	394	394	511	511	530	530	575	575
5	-	425	-	425	-	-	-	-	403	403	425	425	457	457	-	-	-	-	-	-
6	-	451	-	508	-	768	-	819	451	451	473	473	508	508	714	714	768	768	819	819
8	-	568	-	610	-	832	-	1022	543	543	568	568	610	610	781	781	838	838	1022	1022
10	-	708	-	752	-	1067	-	-	673	673	708	708	752	752	991	991	1067	1067	1372	1372
12	-	737	-	819	-	-	-	1422	737	737	775	775	819	819	1130	1130	1219	1219	1575	1575
14	-	927	-	972	-	1257	-	-	889	889	927	927	972	972	1257	1257	1257	1257	-	-
16	-	1016	-	1108	-	1422	-	-	1016	1016	1057	1057	1108	1108	1422	1422	1530	1530	-	-
18	-	1143	-	-	-	1727	-	-	1143	1143	1184	1184	-	-	1727	1727	1727	1727	-	-
20	-	1500	-	-	-	-	-	-	1460	1460	1500	1500	1660	1660	1930	1930	-	-	-	-
24	-	1800	-	-	-	-	-	-	1760	1760	1800	1800	-	-	-	-	-	-	-	-

**ANSI Class 150 through 2500 and equivalent PN**

Valve Size (inches)	"H" About Globe Valve								
	Standard Bonnet				Extension Bonnet				Bellows Bonnet
	ANSI Class 150-300	ANSI Class 600	ANSI Class 900-1500	ANSI Class 2500	ANSI Class 150-300	ANSI Class 600	ANSI Class 900-1500	ANSI Class 2500	ANSI Class 150-300
	PN 20-50	PN 100	PN 150-250	PN 420	PN 20-50	PN 100	PN 150-250	PN 420	PN 20-50
1/2	86	86	-	185	-	-	-	-	225
3/4	124	124	-	185	-	-	-	-	235
1	124	124	185	-	224	227	-	-	235
1-1/2	145	145	187	-	255	255	-	-	252
2	156	156	230	-	256	256	-	-	263
2-1/2	190	190	-	-	295	295	-	-	315
3	210	210	274	-	320	320	384	450	335
4	260	265	334	-	350	355	-	-	337
5	316	316	-	-	423	423	-	-	533
6	322	325	455	480	448	451	555	643	555
8	380	380	471	-	520	520	551	657	624
10	390	415	-	-	560	585	643	-	616
12	443	458	-	-	543	558	-	-	771
14	496	525	-	-	596	625	720	-	-
16	529	565	-	-	669	780	-	-	-
18	663	-	747	-	-	-	-	-	-
20	-	-	-	-	-	-	-	-	-
24	835	-	-	-	-	-	-	-	-

Valve Size (inches)	"H1"																			
	ANSI Class 150-300		ANSI Class 600		ANSI Class 900-1500		ANSI Class 2500		ANSI Class 150	ANSI Class 300	ANSI Class 600	ANSI Class 900	ANSI Class 1500	ANSI Class 2500						
	PN 20-50		PN 100		PN 150-250		PN 420		PN 20	PN 50	PN 100	PN 150	PN 250	PN 420						
	SW	BW	SW	BW	SW	BW	SW	BW	RF	RTJ	RF	RTJ	RF	RTJ	RF	RTJ	RF	RTJ		
1/2	117	-	125	-	-	-	-	-	111	-	117	-	125	-	-	-	-	-	-	
2	133	-	143	-	-	187.5	-	-	127	-	133	-	143	-	187.5	187.5	187.5	187.5	-	-
3	-	159	-	168	-	230	-	330	149	-	159	-	168	-	230	230	230	230	330	330
4	-	184	-	197	-	265	-	368.5	176	-	184	-	197	-	265	265	265	265	368.5	368.5
6	-	284	-	305	-	-	-	-	272	-	284	-	305	-	-	-	-	-	-	-

Valve Size (inches)	"H" About Angle Valve								
	Standard Bonnet				Extension Bonnet				Bellows Bonnet
	ANSI Class 150-300	ANSI Class 600	ANSI Class 900-1500	ANSI Class 2500	ANSI Class 150-300	ANSI Class 600	ANSI Class 900-1500	ANSI Class 2500	ANSI Class 150-300
	PN 20-50	PN 100	PN 150-250	PN 420	PN 20-50	PN 100	PN 150-250	PN 420	PN 20-50
1-1/2	145	145	187	-	255	255	-	-	252
2	156	156	230	-	256	256	-	-	263
3	210	210	274	-	320	320	384	450	335
4	260	265	334	-	350	355	-	-	337
6	322	325	455	480	448	451	555	643	555
3	210	210	274	-	320	320	384	450	335
4	260	265	334	-	350	355	-	-	337
6	323	327	455	-	392	396	555	555	555

## ACTUATOR DIMENSIONS (MM)

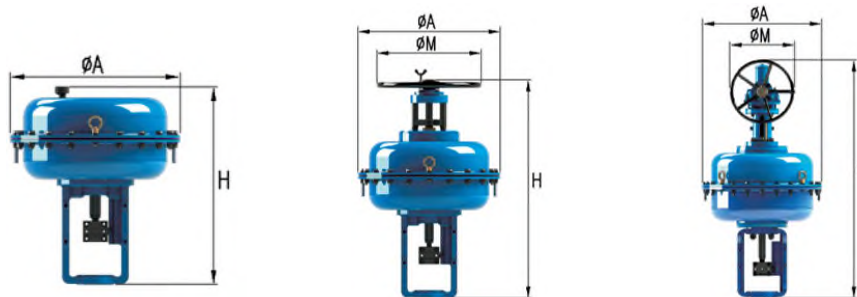

### Diaphragm Actuator Dimensions

Actuator Size	A	Without Handwheel		Top Handwheel		Side Handwheel				
		H		H		M		H		M
		DA	RA	DA	RA	DA, RA	DA	RA	DA, RA	
250	252	332	352	474	474	250	-	-	-	
290	294	369	389	540	540		-	-	-	
370	374	410	430	580	580		-	-	-	
370L	374	-	480	-	655	-	-	-	-	
480	482	629	649	-	-	-	1162	1162	-	
480H	482	-	649	-	-	-	-	1162	500	
550	560	678	698	-	-	-	1210	1210	-	
550L	560	-	756	-	-	-	-	1287	-	

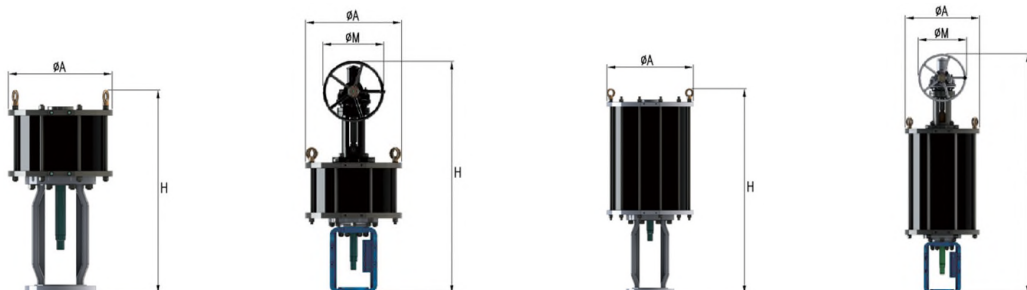

### Cylinder Actuator Dimensions

Actuator Size	A	Stroke	Double Type		Spring Return Type				M
			Without Handwheel	Side Handwheel	Without Handwheel		Side Handwheel		
			H	H	H		H		
			DA	RA	DA	RA			
12	370	100	711	1127	1055	1025	1471	1441	400
		120	731	1147	1055	1025	1471	1441	
		150	821	1272	-	-	-	-	
16	472	100	697	1137	1132	1102	1614	1584	
		120	717 / 877	1157 / 1317	1132	1102	1614	1584	
		150	809 / 907	1282 / 1382	1210	1192	1683	1665	
		200	957	1482	-	-	-	-	
20	578	150	916	1389 / 1540	1322	1322	1795	1795	
		200	966	1489 / 1640	1364	1364	1837	1837	
		300	1133	1873	-	-	-	-	500

## 4000 Series Cage Guided Globe Control Valve

### HOW TO ORDER

Actuator	Series	Trim Type	Trim Style	Plug Type	Body Material <sup>1</sup>
<b>Spring Diaphragm</b>	4000	1 Standard Cage	1 Linear	1 PTFE Seal	2 WCB/A105
870 Air-to-close	4	2 Anti-Cav 1 Stage	2 Equal Percent	2 Graphite Seal	3 316
880 Air-to-open		3 Anti-Cav 2 Stage	3 Mod. Percent	3 Pilot Plug Seal	A 304
<b>Spring Cylinder</b>		4 Anti-Cav 3 Stage		4 Metal Seal	AL 304L
670 Air-to-close		5 Anti-Cav 4 Stage		5 Other	3L 316L
680 Air-to-open		6 Labyrinth			4 Alloy 20
660 Double Acting		7 Notch			7 Hastelloy C
					8 A350 LF2

Packing	Body Gasket	End Connection	Options <sup>2</sup>	Size
T Teflon	S Standard 400°F	S NPT	EB - Ext. Bonnet	1-1/2" - 24"
G Graphite	H High Temp 750°F	SW Socket Weld	BS - Bellows Seal	
LE Low Emission	ST Super Temp 1049°F	BW Butt Weld		
		F1 150		
		F3 300		
		F6 600		
		F9 900		
		F15 1500		
		F25 2500		

<sup>1</sup> Please see the J Flow Controls Configurator for a full list of body materials.

<sup>2</sup> Bellows Seal - Add BL (Example 880-BL41242STF3-200)

Extended Bonnet - Add EB (Example 880-EB41242STF3-200)

PARTS AND SERVICE CONTACT J FLOW CONTROLS.  
I-O MANUALS ARE AVAILABLE ONLINE.



4665 Interstate Drive  
Cincinnati, OH 45246  
513-731-2900  
[jflowcontrols.com](http://jflowcontrols.com)

