

## JTMZ Series Multi-Turn Electric Actuator



High performance and high reliability  
Fully compliant with the latest international standards and regulations  
More applicable to a wide range of specifications and higher cost performance  
Compact design is better suited for a variety of industrial applications





**JTMZ Series Multi-Turn Electric Actuator Product Structure**

JTMZ series electric actuator is developed independently as new generation, integrating up-to-date various automatic control technology including field bus technology, absolute coding technology, remote control technology and magnetic switch control based on existing mature technology adopting advanced actuator design and fabrication from foreign countries.

- Categorization By Motion Mode of Driven Part: JTMZ Multi-Turn (Linear) / JTM Part-Turn (Rotary)
- Categorization By Actuator Working Condition: Outdoor Type/ Explosion-Proof Type
- Categorization By Actuator Control Performance: Basic Type(Mechanical Type)/ Mechatronic Type(Integral Model/Intelligent Model)
- Categorization By Actuator Control Mode: On-Off Model /Modulating Model





### Driving Motor

Motor has low inertia and large torque with initial peak torque reached in short time. Almost no overrun when the motor is not excited. Temperature sensor in high precision is installed Interior motor. Regulate over-temperature limit through control system to avoid motor damage caused by overheating.

### Anticorrosion Housing

Actuator outer surface adopts metallic paint dedicated to alloy aluminum with strong adhesion. It is uvioresistant, anticorrosive high-build, which comprehensively improves service life and self-cleaning of the coating, and adapts to various kinds of hostile manufacturing environment.



### Driving Gear

Actuator driving gear selects bronze-alloy worm gear and alloy-steel vortex rod to constitute speed reduction actuator in high precision. Worm gear and vortex are separately immersed in lubricating oil adapting to maximum surrounding temperature variation and optimize service life.

### Manual/Electric Operation

JTM quarter-turn actuator adopts automatic construction of completely separate design for manual driving gear and electric driving gear without switching operation.

JTMZ linear actuator adopts design prioritizing electric operation with mechanical locking function to avoid misoperation and ensure to cut off electric motor control circuit in manual operation state to ensure manual operation security.

### Terminal Unit

During eld wiring operation, the independent sealed terminal cavity guarantees sealing integrity interior electric actuator and meet explosion-proof requirement.

### Output Interface

Actuator ange meets standards ISO5210/5211(GB12222/GB 12223) and also provide ange interface meet standard JB2920 and customization as per special requirement is also available.

### Leakproof Structure

Actuator employs double sealing structure to ensure it is completely waterproof and dustproof, standard with protection class IP67 and up to IP68.





## Man-Machine Interface LCD Display

Apply LCD display graphic dot matrix with background illumination to display working states and alarms of torque, valve position and limit setting in Chinese, digits and graphics. It can be clearly observed and set even at night with two LED indicators in red and green which have strong penetrability even in harsh environment to let users be clear about the actuator working state at a glance.

### Various Control Mode

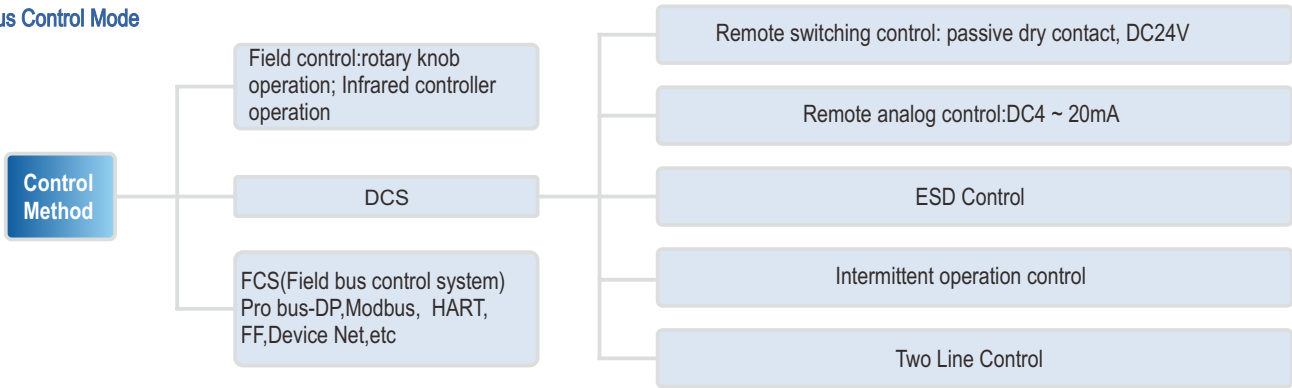

### Signal Output

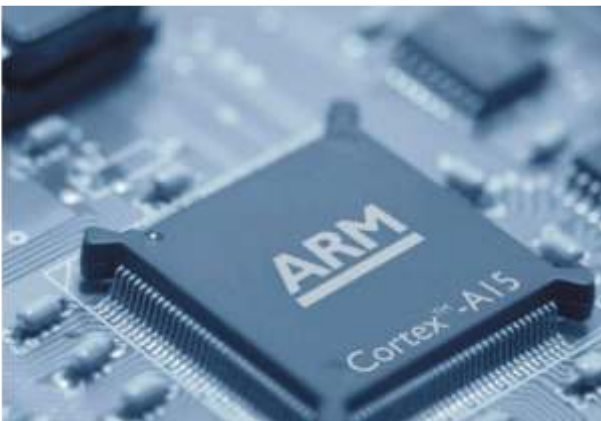
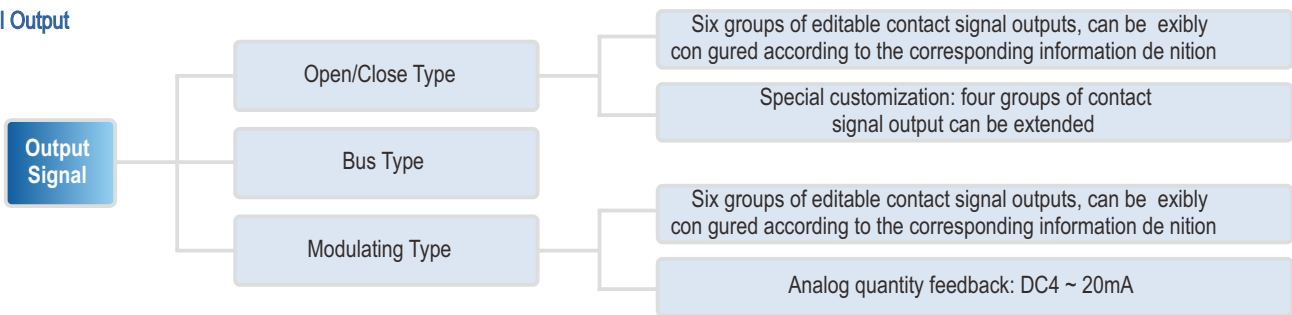

### Highly Integrated Control Circuit

Mature and reliable control circuit designing scheme employ core controller of 32-bit embedded large-capacity ARM chip by large-scale integrated circuit technology to reduce the quantity of discrete components and improve the overall reliability. Effectively solve motor inertia problem by Inertia adaptive stepping control strategy to achieve accurate positioning and to improve the control accuracy.



### Intelligent Backup Power System

In the cases of power failure or power loss, the backup power can be started only by touching the knob to power the key circuit and wake up the display to show the current valve state. (Optional)



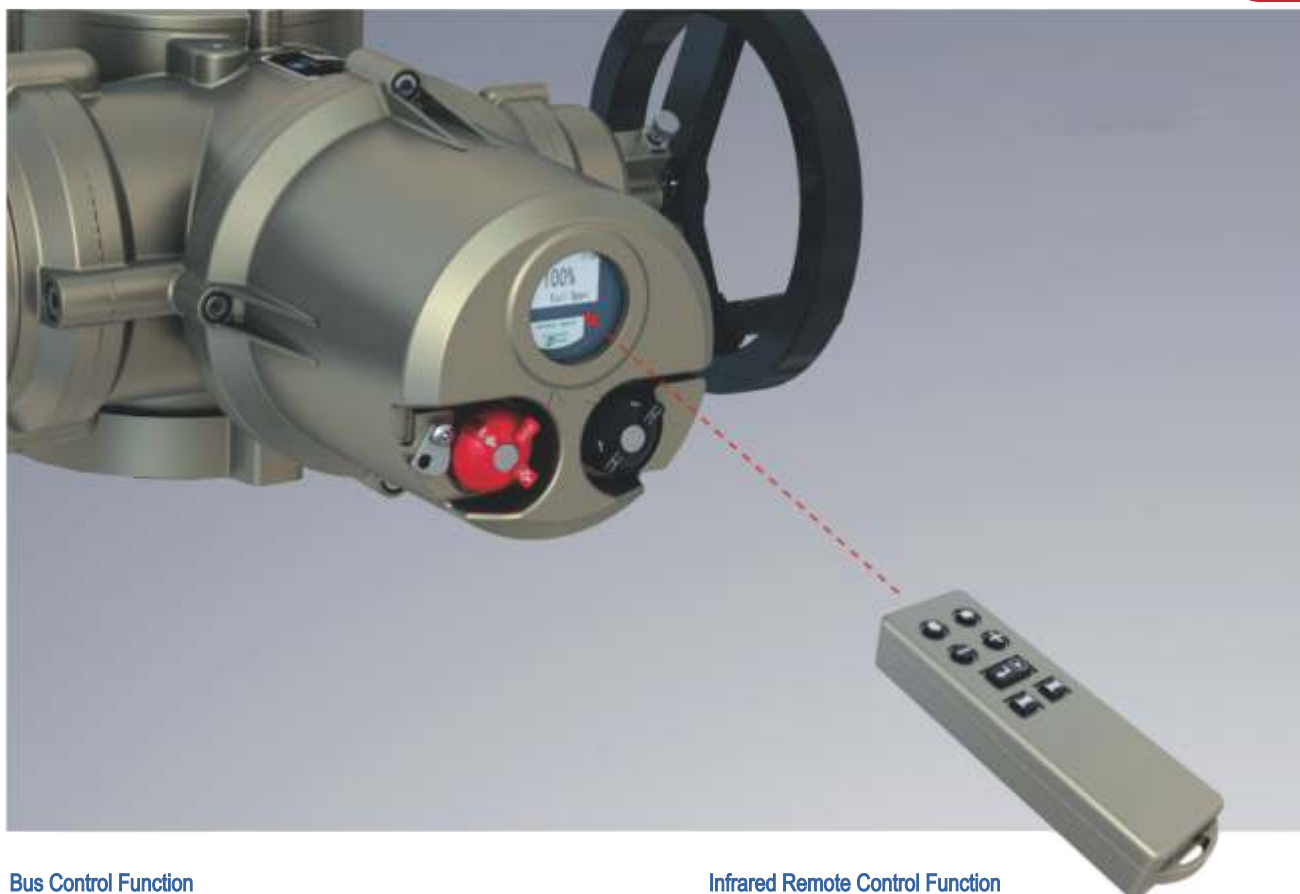

**Bus Control Function**

The communication module applies the independent construction superimposed on the motherboard to meet the requirements of different communication media and different communication protocol system. The current supportable communication protocols are Modbus RTU/PROFIBUS-DPV0/DPV1/HART/FF/DeviceNet. (Optional)

**Superior Anti-Interference Capability**

Apply cutting-edge anti-interference design of microelectronic circuit and all control signals are effectively photoelectric isolated, passing EMC electromagnetic compatibility test, which is applicable to all kinds of complex electromagnetic surroundings.

**Infrared Remote Control Function**

Actuator adopts advanced infrared remote control technology to realize man-machine dialogue through sealed dialogue window without opening actuator cover. Even under hazardous circumstance, the remote controller of intrinsic safety type can achieve parameter setting and remote control securely.

**System Software**

All softwares are applied with independent intellectual property rights making it easy to upgrade the system and multiple language options are available.

**Reliable And Comprehensive Data Recording**

Apply nonvolatile data memory to save all setting parameters, operation data, fault information and history record, and no need to worry about data loss in the case of power failure.





### Precise Torque Measurement And Protection

The professional designed torque measurement system to guarantee the actuator overload protected and monitor valve torque variance in real time.

**Standard with electronic torque measurement:** to realize continuous measurements by measuring real-time motor current, voltage and magnetic flux, calculate comprehensively combined with a single chip microcomputer to get accurate output torque. The system reliability is improved as no need to worry about mechanical wear.

**Optional with mechanical and electrical torque measurement:** the system adopts absolute coding with lever amplification of device to precisely transfer the digital data to the CPU for processing so to collect high-precision torque parameters and higher measurement accuracy and repetition accuracy with retaining the advantageous mechanical torque measurement in maturity, stability and reliability.

### Precise Valve Position Stroke Measurement And Protection

JTMZ actuator applies 24bit absolute encoder to measure the valve position stroke. The stroke reaches 4096 circles with single-cycle angular resolution  $0.088^\circ$ . The encoder integrates magnetism, electricity and machinery. In the case of power loss, it is unnecessary to worry about valve position loss by manual operation. Advanced boundary anti-vibration technology ensures high speed, stability and reliability of output data, thus effectively improving the stability and reliability of the system.

### Electric Motor Detection and Protection

**Overheat:** Electric motor operation is prohibited when electric motor temperature exceeds the set overheat protection value displaying electric motor overheat alarm information.

**Overload And Short Circuit:** Introduce the circuit of ADI precision voltage conversion chip to meet precision detection needs of extensive current variation and to meet related standards of overload time-delay resistance and short circuit protection.

**Instantaneous Inversion Protection:** Adopt instantaneous inversion time-delay control technology of control system halt prior to executing reverse action after certain delay in the case of actuator receiving reverse operation signal during operation to prevent damages to mechanical gearing parts.

**Electronic Brake:** Modulating type electric actuator ensures valve stops at the set valve position by setting dead band and electronic brake.

### Intelligent Control Security Protection

**ESD Protection:** provides flexible emergency protection function regulating emergency operation control mode through parameter setting. Separately set operation mode at emergency protection, such as full open, full close or position retaining.

**Control Mode Protection:** The operation state of remote, on site or stop can be locked through mechanical locker on the electrical box cover to avoid misoperation. Password is required to enter setup interface to change the parameter setting.

**Passive Monitoring Function:** Valve position information can be displayed accurately at power failure state, and can realize the function of searching the actuator running data without external power supply.

**Intelligent Network Security Protection(Optional):** Support dual redundant field bus communication. In the case of failure occurs at one channel, communication automatically switches to another channel to ensure the actuator communication and operation in dual redundant communication mode.



### Power Detection and Protection

**Phase Sequence Automatic Identification:** Introduce automatic identification circuit of photoelectric isolation phase sequence. Users can access to the power line according to any phase sequence and valve always operates in correct direction.

**Missing Phase Protection:** Electric motor is prohibited to operate in the case of any phase missing in three-phase power with alarm information of missing phase.

**Over Voltage And Under Voltage Protection:** Electric motor is prohibited to operate in the case of three-phase power supply voltage is higher than the set over voltage value, or lower than the set under voltage value with alarm information of over voltage or under voltage.

### Intelligent Self-Detection And Diagnosis

Actuator has self-detection alarm function to automatically check functional components at power-on state to guarantee fault-free operation. Implement real-time detection on functional components and immediately stop operation once failure detected. Meanwhile, actuator sends out on-site and remote alarm signals for user to find out the cause promptly, and restore the operation by timely troubleshooting.

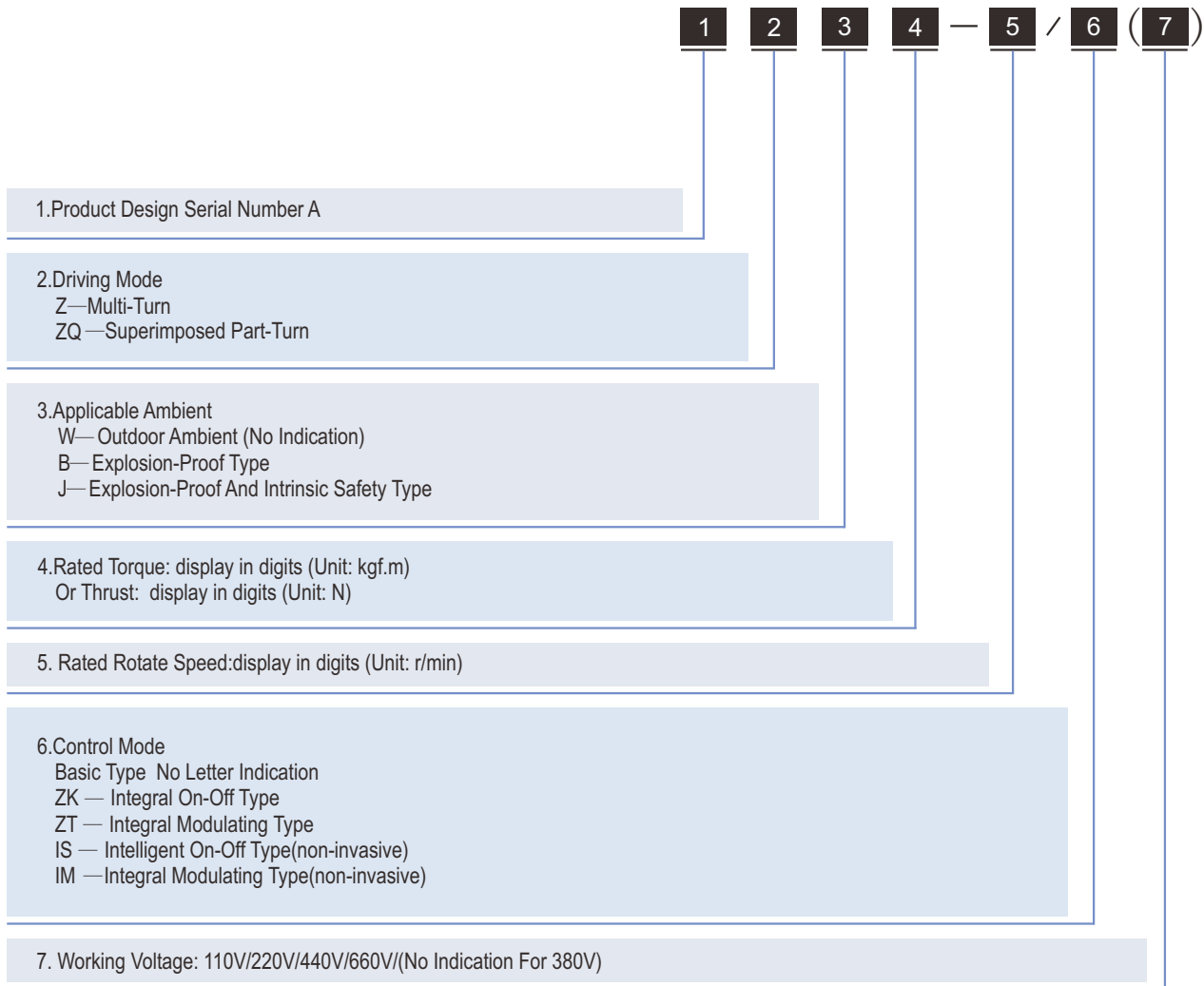

## Working Ambient And Performance Parameter

- Power Supply  
380V AC±10%/50Hz±5%,  
or customization is available  
220V AC±10%/50Hz±5%,  
or customization is available
- Input Signal  
A) Analog Quantity: 4mA~20mA DC,  
input impedance 250Ω  
B) On/Off volume active 24V DC  
C) Pro bus-DP Or MODBUS(Optional)
- Output Signal  
A) 4mA~20mA DC, load impedance≤750Ω  
B) Six groups of passive contacts  
C) PROFIBUS Or MODBUS(Optional)
- Intrinsic Error Limit: ≤ 1%
- Repeatability Error: ≤ ± 1%
- Dead Band Setting: 0.1%~9.9% Adjustable
- Protection Class: Standard with IP67  
(30mins for 1meter under water);  
optional with IP68  
(72hours for 6meters under water)
- Ambient Temperature: Normal with -20℃~+60℃  
Special with -40℃~+70℃
- Ambient Humidity: ≤ 95%(+25℃)
- Operation Mode: IS On-Off Type S2-15min short-time working mode  
IM Modulating S4-25% Intermittent working mode
- Explosion-proof Sign: Exdl, Exdib II BT4 and Exdib II CT4

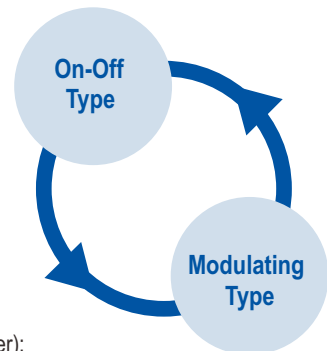



JTMZ Series On-Off Type Electric Actuator Technical Parameter

Model	Output Rotate Speed	Nominal Torque	Motor Pole No.	Motor Power	Rated Current	Manual Speed Ratio	Max. Valve Rod Diameter	Weight
	R/min	N.m		KW	A	I	Mm	Kg
JTMZ10/IS	18	100	4	0.25	1.03	1 : 80	28	30
	24		4	0.25	1.03	1 : 60		
	36		4	0.37	1.38	1 : 40		
	48		4			1 : 30		
JTMZ15/IS	18	150	4	0.37	1.38	1 : 80	28	30
	24		4	0.37	1.38	1 : 60		
	36		4	0.55	2.2	1 : 40		
	48		4			1 : 30		
JTMZ20/IS	18	200	4	0.55	2.2	1 : 80	40	36
	24		4	0.55	2.2	1 : 60		
	36		4	0.75	2.62	1 : 40		
	48		4	0.75	2.62	1 : 30		
JTMZ30/IS	18	300	4	0.55	2.2	1 : 80	40	36
	24		4	0.55	2.2	1 : 60		
	36		4	0.75	2.62	1 : 40		
	48		4	0.75	2.62	1 : 30		
JTMZ45/IS	20	450	4	1.1	4.0	1 : 72	48	43
	24		4	1.1	4.0	1 : 60		
	40		4	1.5	5	1 : 36		
	48		4	2.2	6.3	1 : 30		
JTMZ60/IS	20	600	4	1.1	4.0	1 : 72	48	47
	24		4	1.5	5	1 : 60		
	40		4	1.5	5	1 : 36		
	48		4	2.2	6.3	1 : 30		
JTMZ90/IS	20	900	4	2.2	6.3	1 : 72	60	54
	24		4	2.2	6.3	1 : 60		
	40		4	3	7.9	1 : 36		
	48		4	3	7.9	1 : 30		
JTMZ120/IS	20	1200	4	2.2	5.25	1 : 72	60	58
	24		4	3	9	1 : 60		
	40		4	4	11.9	1 : 36		
	48		4	4	11.9	1 : 30		
JTMZ180/IS	18	1800	4	4	11.9	1 : 80	70	150
JTMZ250/IS	18	2500	4	5.5	13.3	1 : 80	70	162
JTMZ350/IS	18	3500	4	7.5	17.1	1 : 80	80	171



JTMZQ Series (Superimposed) On-Off Type Electric Actuator Technical Parameter



Model	Nominal Torque	Output Rotate Speed	90° time	1st Actuator	Motor Power	Rated Current	Secondary Speed Ratio	Weight
	N.m	R/min	S		KW	A	I	Kg
JTMZQ200/IS	18	0.48	31	JTMZ10/24IS	0.25	1.03	50 : 1	55
JTMZQ300/IS	24	0.632	24	JTMZ20/24IS	0.55	2.2	38 : 1	73
JTMZQ400/IS	36	0.632	24	JTMZ30/24IS	0.55	2.2	38 : 1	73
JTMZQ700/IS	48	0.6	25	JTMZ45/24IS	1.1	4.0	40 : 1	101
JTMZQ1000/IS	18	0.545	28	JTMZ60/24IS	1.5	5	44 : 1	127
JTMZQ1600/IS	24	0.462	33	JTMZ90/24IS	2.2	6.3	52 : 1	134
JTMZQ2400/IS	36	0.462	33	JTMZ120/24IS	3	9	52 : 1	138
JTMZQ3200/IS	48	0.358	42	JTMZ120/24IS	3	9	67 : 1	188
JTMZQ4000/IS	18	0.273	55	JTMZ180/18IS	4	11.9	66 : 1	432
JTMZQ6300/IS	24	0.25	60	JTMZ250/18IS	5.5	13.3	72 : 1	690
JTMZQ8000/IS	36	0.225	67	JTMZ250/18IS	7.5	17.1	80 : 1	848



JTMZ Series Electric Actuator Outline Dimension

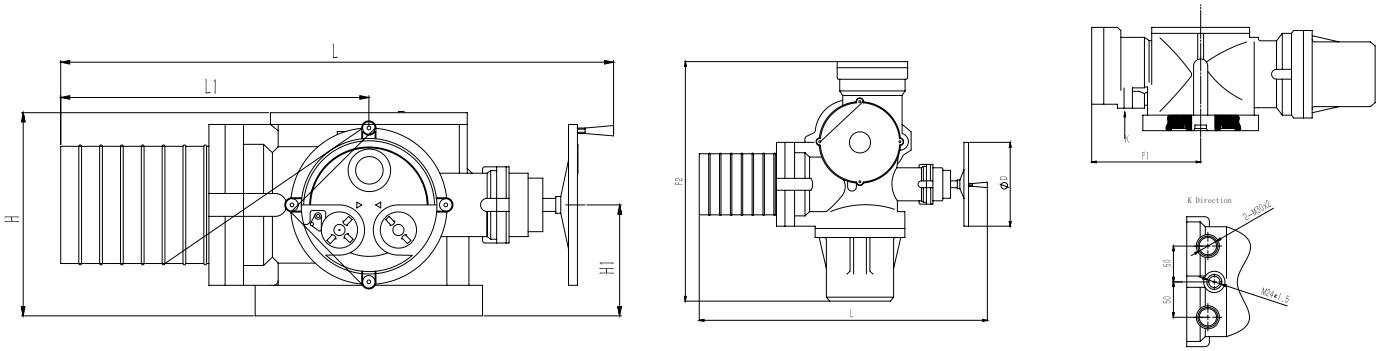

Actuator Parameter Actuator Model No.	H1	H	L1	L	F1	F2	ΦD
JTMZ10-15	119	247	300	638	184	522	200
JTMZ20-30	119	247	300	638	184	522	200
JTMZ45-60	124	248	335	676	198	567	250
JTMZ90-120	142	263	390	745	217	607	250
JTMZ180-250	205	337	475	819	285	651	350
JTMZ350	205	337	500	844	285	651	350

JTMZQ Series Electric Actuator With Base Outline And Connecting Dimension

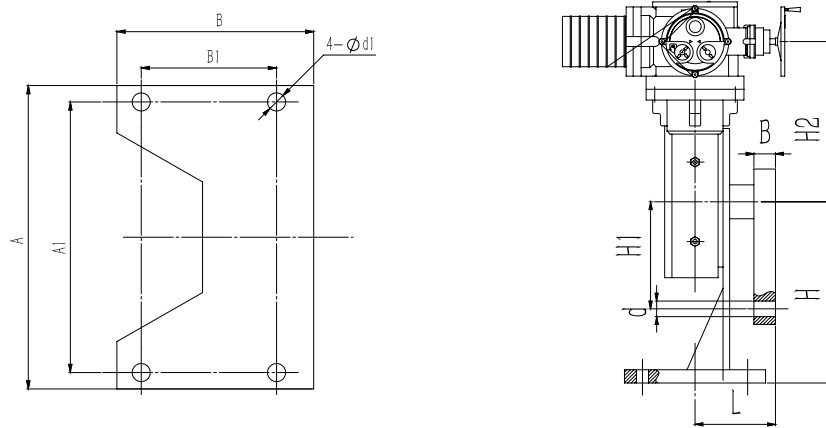

Actuator Parameter Actuator Model No.	A	A1	B	B1	d1	d	H	H1	H2	B	L
JTMZQ200	450	390	260	215	22	25	300	250	270	30	155
JTMZQ300	450	390	260	215	22	25	300	250	300	30	155
JTMZQ400	450	390	260	215	22	25	300	250	300	30	155
JTMZQ700	450	390	260	215	22	25	300	250	334	34	155
JTMZQ1000	500	440	260	215	22	30	300	300	354	34	165
JTMZQ1600	500	440	260	215	22	30	300	300	422	34	165
JTMZQ2400	500	440	260	215	22	34	300	300	422	34	165



JTMZ Series Electric Actuator Connecting Flange Dimension

1. Standard JB2920

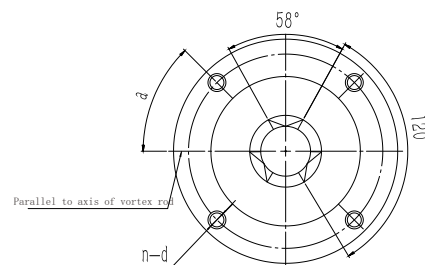
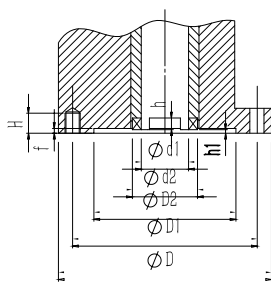

Model	JTMZ10/JTMZ15	JTMZ20/JTMZ30	JTMZ45/JTMZ60	JTMZ90/JTMZ120	JTMZ180/JTMZ250	JTMZ350			
<b>JB2920</b>									
Motor Frame No.	2	2I	3	3I	4	5	5I	7	8
D	145	115	185	145	225	275	230	330	380
D1	120	95	160	120	195	235	195	285	340
D2	90	75	125	90	150	180	150	220	280
d1	30	26	42	30	50	62	50	73	82
d2	45	39	58	45	72	82	72	98	118
f	5	5	5	5	5	5	5	6	6
h	8	6	10	8	12	14	12	16	20
h1	2	2	2	2	2	2	2	3	3
H	15	15	15	15	30	34	30	30	30
n-d	4-M10	4-M8	4-M12	4-M10	4-M16	4-M20	4-M16	4-Φ27	8-Φ22
a	45°	45°	45°	45°	45°	45°	45°	45°	22.5°

2. Standard GB/T 12222-2005(SO 5210 )

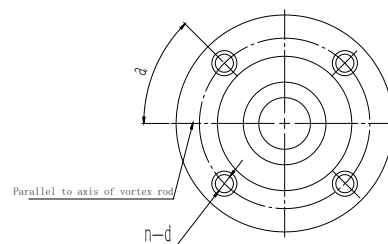
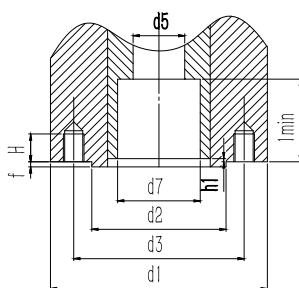

Model	JTMZ10/JTMZ15	JTMZ20/JTMZ30	JTMZ45/JTMZ60	JTMZ90/JTMZ120	JTMZ180/JTMZ250	JTMZ350
<b>GB/T 12222-2005(SO 5210)</b>						
Flange No.	F10	F14	F16	F20	F30	F35
d1	125	175	210	300	350	415
d2 (f8)	70	100	130	200	230	260
d3	102	140	165	254	298	356
d5	30	40	50	65	85	85
d7	42	60	80	100	120	120
f	3	4	5	5	5	5
H	15	24	30	24	30	30
h1max	3	4	5	5	5	5
lmin	45	65	80	110	130	130
n-d	4-M10	4-M16	4-M20	8-M16	8-M20	8-M30
a	45°	45°	45°	22.5°	22.5°	22.5°
h1	3	3	3	3	3	3



JTMZQ Series Electric Actuator Outline And Connecting Flange Dimension

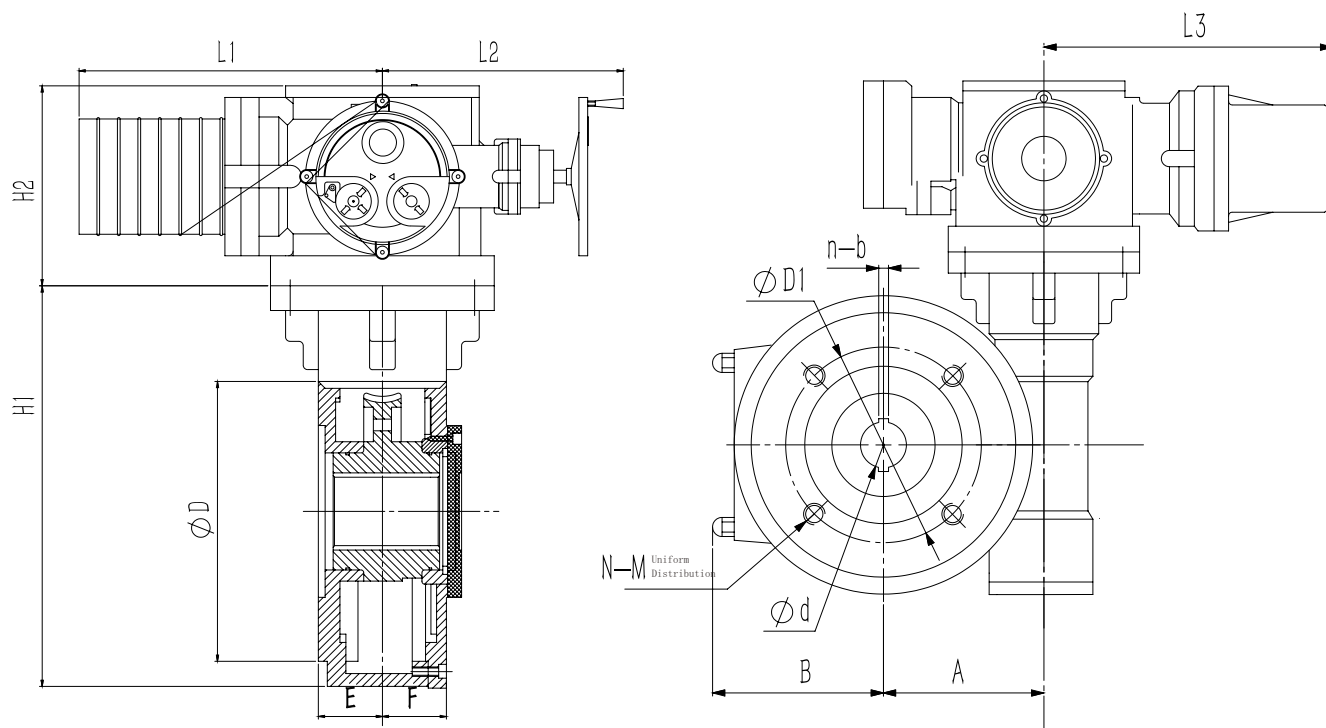

Actuator Parameter	A	B	D	E	F	D1	N-M	D	N-b	H1	H2	L1	L2	L3
JTMZQ200/IS	93	100	125	51	50	102	4-M10	32	1-8	237	247	300	338	338
JTMZQ120/IM														
JTMZQ300/IS	94	104	175	53	51	140	4-M16	38	1-10	290	247	300	338	338
JTMZQ200/IM														
JTMZQ400/IS	94	104	175	53	51	140	4-M16	42	1-10	290	247	300	338	338
JTMZQ300/IM														
JTMZQ700/IS	125	131	210	62	62	165	4-M20	50	1-16	342	248	335	341	369
JTMZQ400/IM														
JTMZQ1000/IS	140	146	300	65	70	254	8-M16	64	2-18	380	248	335	341	369
JTMZQ700/IM														
JTMZQ1600/IS	162	170	300	87	75	254	8-M16	75	2-20	528	263	390	355	390
JTMZQ1000/IM														
JTMZQ2400/IS	162	170	300	87	75	254	8-M16	85	2-20	528	263	390	355	390
JTMZQ1600/IM														
JTMZQ3200/IS	236	180	350	88	95	298	8-M20	105	2-28	570	263	390	355	366
JTMZQ2400/IM														
JTMZQ4000/IS	345	238	415	142	133	356	8-M30	140	2-36	810	337	475	344	366
JTMZQ3200/IM														
JTMZQ6300/IS	410	316	470	160	145	406	8-M36	160	2-40	970	337	475	344	366
JTMZQ4000/IM														
JTMZQ8000/IS	460	360	560	150	155	483	12-M36	180	2-45	1080	337	475	344	366
JTMZQ6300/IM														

## Electric Actuator Standard Selection Guide For Valve



### Gate Valve

PN \ DN	50	65	80	100	125	150	200	250	300	350	400	450	500	600	700	800
1	2.5	2.5	2.5	5	5	10	10	15	15	20	30	30	45	45	60	60
2.5	2.5	2.5	5	10	10	15	15	20	20	30	30	45	45	60	60	90
6	2.5	5	10	10	15	15	20	20	30	30	45	45	60	90	90	90
10	10	10	10	15	15	20	20	30	45	45	60	90	90	90	120	120
16	10	10	15	20	20	30	30	45	60	90	120	120	180	180	180	250
25	10	10	15	20	30	30	45	60	90	120	120	120	180	250	350	500
40	10	10	15	20	30	45	60	90	90	120	180	180	250	350	500	650
64	10	10	20	30	45	60	60	90	120	180	250	250	350	500	800	1000
100	15	20	30	45	60	60	90	120	180	250	350	500	600	800	1000	1500
160	20	30	45	60	90	90	120	180	250	350	500	800	1000	1200	1500	2000
200	20	45	60	90	90	120	180	250	350	500	700	1000	1200	1600	2000	3000
320	30	60	90	120	180	180	250	350	500	700	1000	1500	2000	2400	3000	4000

### Globe Valve

PN \ DN	15	20	25	32	40	50	65	80	100	125	150	200	225	250	300	350
6	5	5	5	5	5	5	5	10	10	15	20	35	45	60	60	90
10	5	5	5	5	5	5	8	10	15	20	30	45	60	60	90	120
16	5	5	5	5	10	10	10	20	30	30	45	60	90	120	180	180
25	5	5	5	10	10	15	20	30	30	45	50	90	120	180	250	350
40	5	5	10	10	20	30	30	45	45	60	90	120	180	250	350	500
64	5	10	10	20	30	30	45	45	60	120	120	180	250	350	500	700
100	10	10	20	25	30	30	45	60	90	120	180	350	400	550	800	1000
160	10	10	30	30	45	45	60	100	120	180	350	550	650	800	1200	1600
320	10	20	30	45	60	90	100	180	250	350	600	1000	1300	1600	2400	3200

### Ball Valve

PN \ DN	50	65	80	100	150	200	225	250	300	350	400	450	500	600	700	800
16	5	10	10	20	60	60	90	120	200	250 Z15	400 Z20	500 Z30	600 Z30	800 Z45	1200 Z60	2500 Z120
25	5	10	20	20	60	90	120	200	250 Z15	400 Z20	500 Z30	600 Z30	800 Z45	1200 Z60	2000 Z90	3000 Z120
40	10	20	20	40	90	200	200	250 Z15	400 Z20	500 Z30	600 Z30	800 Z45	1200 Z60	2000 Z90	3000 Z120	6000 Z250
64	20	20	30	60	200	200	300 Z20	400 Z20	600 Z30	800 Z45	1000 Z60	1200 Z60	1500 Z90	3000 Z120	4500 Z180	8500 Z350
100	20	40	60	90	200	400 Z20	500 Z30	700 Z45	1000 Z60	1200 Z60	1500 Z90	2000 Z90	3000 Z120			

### Butterfly Valve





PN \ DN	100	150	200	250	300	350	400	450	500	600	700	800	900	1000	1200	1600
2.5	10	20	40	60	90	120	120	200	250 Z15	400 Z20	500 Z30	700 Z45	800 Z45	1000 Z60	1500 Z90	2500 Z120
6	10	20	40	60	90	120	200	250 Z15	300 Z20	500 Z30	700 Z45	1000 Z60	1500 Z90	2000 Z90	2500 Z120	3800 Z180
10	10	30	60	90	120	200	300 Z20	400 Z20	500 Z30	600 Z30	800 Z45	1200 Z60	1500 Z90	2000 Z90	3000 Z120	4500 Z180
16	20	40	90	120	200	250 Z15	300 Z20	400 Z20	500 Z30	800 Z45	1200 Z60	2000 Z90	2500 Z120	3500 Z120	4500 Z180	6000 Z250
25	30	60	120	200	300 Z20	400 Z20	450 Z30	500 Z30	700 Z45	1000 Z60	1500 Z90	2500 Z120	3500 Z120	4500 Z180	6000 Z250	7500 Z350
40	40	90	200	250 Z15	400 Z20	600 Z30	700 Z45	800 Z45	1000 Z60	2000 Z90						
64	90	200	250 Z15	300 Z20	500 Z30	700 Z45	1000 Z60	1000 Z90	2500 Z120	3800 Z180						



## Motion Mode Classified By Ambient And Driving Method



Actuator Enclosure Design Differentiates By Working Ambient

	Installation Position	Protection Type
	General environments like indoor, outdoor, short-time immersion risk	All-weather IP 65/67/68
	Coastal, offshore environment	All-weather IP 65/67 + marine corrosion protection
	Flammable and explosive environment	All-weather IP 65/67+explosion-proof ExdI/dII( )
	Corrosive gas environment	All-weather IP 65/67+anti-corrosion special protection
	Nuclear base	All-weather IP 65/67+nuclear class 1EK1/K2/K3 )

Classifications By Application Ambient:

Category	Application Ambient	Remarks
Category I	Applied in gas environment of coal mine	II A Representative gas is propane II B Representative gas is ethylene
Category II	Applied in other explosive gas environments except for methane gas environment of coal mine	II C Representative gases are hydrogen and acetylene

Classifications of T1-T6 By Maximum Surface Temperature

T1	T2	T3	T4	T5	T6
450°C	300°C	200°C	135°C	100°C	85°C

Operation mode of the driven device directly determines the actuator gearing mode

Part-Turn (Rotatory )	Multi-Turn (Linear )
<p>Rotary actuator is also known as part-turn actuator with compact structure, realizing self-lock to retain valve position even in power-failure condition.</p> <p>The gears are carefully designed to improve shock resistance and durability. Mechanical limit is designed to prevent driving device from being damaged in manual operation though it is equipped with stroke limit device.</p> <p>Adopt superposed XQ series planetary reducer referring to valve device with large torque, co-axially mounted with the output shaft and rotates in the same direction.</p>	<p>Multi-Turn electric actuator can be installed either directly on the driven device or in conjunction with the gearbox.</p> <p>To meet various function needs, torque and rotation speed in wide range should be satisfied with self-locking function to retain the threshold position.</p> <p>For security purpose, manual override cannot rotate in electric operation and electric drive take precedence over manual drive.</p> <p>Adopt superposed XW series planetary reducer referring to valve device with large torque, coaxially mounted with the output shaft and rotates in the same direction.</p>
<p>Butter y Valve Ball Valve Air Valve,etc</p>	<p>Gate Valve Globe Valve Regulating Valve,etc</p>

# Operation Mode and Control Performance of Drive Gear



	On-Off Type	Modulating Type
	Full open or full close	Intermediate stop
Recommended maximum operating frequency :(guaranteed service life)	20~30 times/day	360 times/day
Motor Working Mode	S2 short-time working mode Transient operation, sufficient halt between two starts is required to completely cool the motor. Depend on different load characteristics, rated time are 10min/15min.	S4 periodic working mode with initialization phase Circulation process for periodic working mode with initialization phase including: Initialization Phase Stable Running Phase Halt Phase
Motor maximum start frequency	360 times start/hr	1200 times start/hr
General Characteristics Of Alternating Current Motor	Electric Motor Dedicated To Valve Insulation Class F Waterproof Enclosure Built-In Overheat Protection Device	

The type of motor depends on the load type of driven device.

## Control Box Selection

For easy installation, user is recommended to choose actuator with integrated control box or self-designed control cabinet. Various control cabinet options are available for all kinds of actuators. Integrated control cabinets applied for on-off or modulating model are equipped with local remote selectors.

The intelligent controller combines the advantages of the traditional controller and the flexibility of the microprocessor and absolute position encoder. It has friendly user interface and non-intrusive design, etc. All series of actuators and various control modes can realize communication

Basic Control	Integrated Analog Quantity Control	Integrated Bus Control
The control unit is designed by the user and located in the remote control cabinet. All information provided by actuator sensor need to be processed by user's control logic including stroke limit, torque limit, overheating, position feedback, etc.	The integrated control system incorporates control unit and motor commutating contactor, directly processing various commands from the control system. After parameter setting completed, the controller completes all kinds of functions, including on-off operation, security protection and state output. In addition, it provides a local controller, optional with local control or remote control.	Multiple actuators or other instruments are controllable by integrated field bus control through a twisted pair and transfer and exchange a great deal of information. It also provides a simple and efficient pre-maintenance solution.

# Control Mode Comparison



JTMZ provides advanced control systems for a wide range of actuators to meet various valve automation requirements, such as multiline or eldbus control, integrated controller or non-integrated controller.

Characteristics, principles and advantages of various controls are shown as below:

		Basic type	Integrated integral type	Integrated intelligent type
operating principle	Position Signal	Contactor (On-Off Type) Potentiometer (Regulating Type)	Contactor (On-Off Type) Potentiometer (Regulating Type)	Absolute Encoder
	Control Logic	External control (designed by the user)	Integrated analog control	Integrated digital control
	Motor Commutation Contactor	External	Built-in	Built-in
	Actuator Protection	Torque switch, thermal protection switch, etc(dedicated to user controlled system)	Built-in (torque limit switch can be configured with motor thermal protection switch, etc.)	Built-in (torque limit switch can be configured with motor thermal protection switch, etc.) Automatic diagnostic function
Control Mode	Multiline Control And Fieldbus Control	<p>Multiline Control</p>	<p>1. Multiline control (solid line) 2. Fieldbus control (dotted line)</p>	<p>1. Multiline control (solid line) 2. Fieldbus control (dotted line)</p>
		Strength	Suitable for severe working conditions (high temperature, high vibration, etc.)	<ul style="list-style-type: none"> <li>Economical turnkey solutions</li> <li>Stable and reliable</li> <li>Convenient for wiring and installation</li> <li>Convenient for field debugging</li> </ul>



4665 Interstate Drive - Cincinnati OH 45246  
 TOLL FREE PHONE: 866.95J.FLOW  
 Phone: 513.731.2900 - Fax: 513.731.6939

The details of this catalog are subject to change without prior notification.