

DHC-400

DC Digital High-Resolution Controller

The Peaktronics DHC-400 is a high performance digital positioner intended to control DC actuators, providing 450 points of resolution with quarter turn actuators ranging from 2 sec to 120 sec. The DHC-400 has many automatic advanced features that will enhance any actuator while making it easy to install and set up. The DHC-400 can replace a DMC-100 or DMC-102 standard size controller in most applications to upgrade performance.

The simple three button control is used to configure all parameters the unit needs for a wide variety of applications, and allows the *open* and *closed* positions to be easily set for direct or reversing acting without any rewiring. The unit can be configured for various command types (4-20mA, 1-5V, 0-5V, 0-10V, 2-10V, or a Digital command) and its default operation upon loss of command. The multicolor LED Fault indication displays up to 15 different conditions (including "Low Battery Voltage").

Various option modules are easily plugged into the unit, providing other features such as a position feedback signal, auxiliary switches, fault relay contact, or digital communications. A wide range of data is accessible through a digital communications module, providing additional control or information.



FEATURES

- 10 to 30 VDC operating voltage range with motors rated up to 60A locked rotor or 10A running current.
- Solid state motor driver with thermal and overcurrent protection provides reliable service beyond the life of the actuator motor.
- Positions to $\pm 0.1^\circ$ with quarter-turn actuators ranging from 2 sec to 120 sec (with or without a mechanical brake). **Electronic Brake** feature can eliminate mechanical brake.
- **Adaptive Control** feature continuously adjusts for load and actuator conditions and eliminates calibration procedures and auto-cal operations.
- **Polarity Detection** feature allows direct or reverse acting operation without re-wiring.
- **Stall Detection** feature protects actuator motor from a stall condition.
- Adjustable **Motor Current Trip** (0-12A) setting limits actuator torque and battery/power supply current requirements.
- **Electronic Surge Limiting** reduces wire size and battery/power supply requirements to 20% of locked rotor current.
- Automatic **Duty Cycle Control** feature prevents motor damage due to overheating and prevents shutdown of a process due to a thermal overload switch.
- Operating temperature range of 0 to 60°C

OUTLINE

DHC-400 10-30VDC

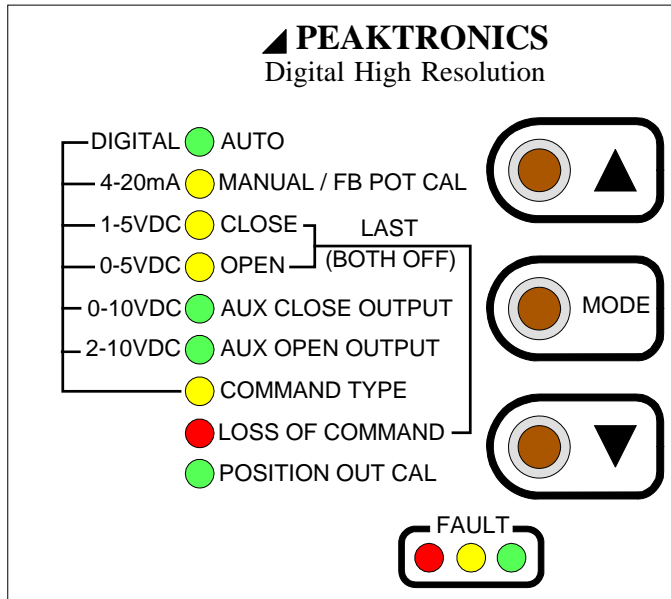

FRONT PANEL

ELECTRICAL CONNECTIONS

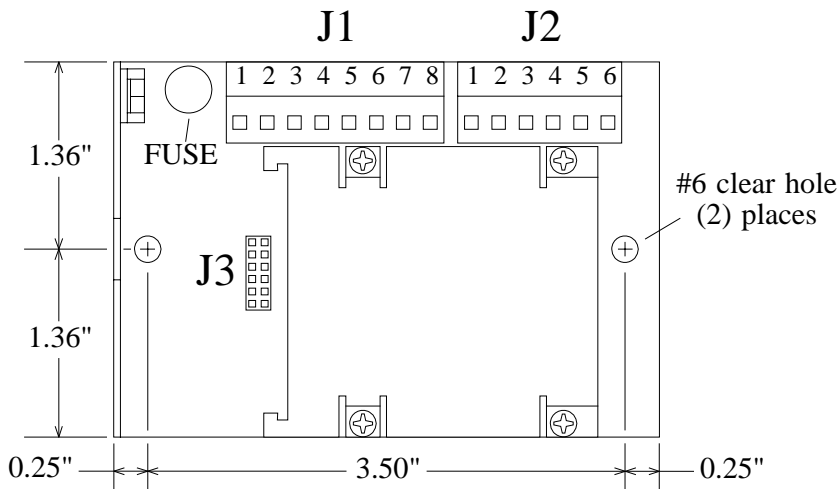
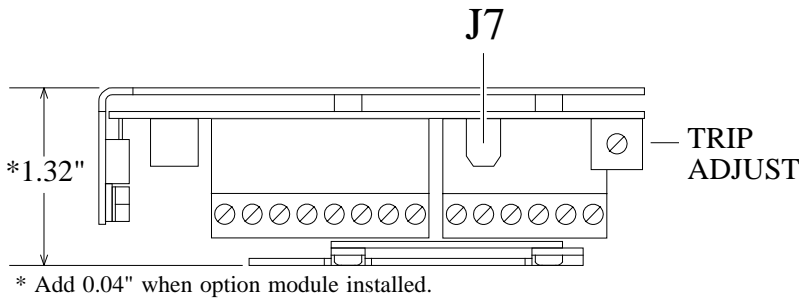
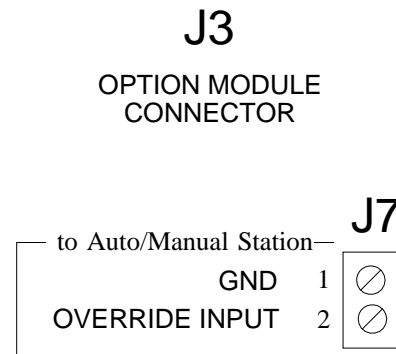
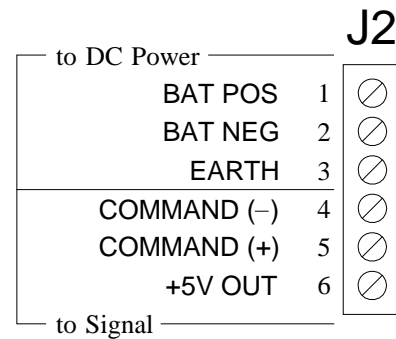
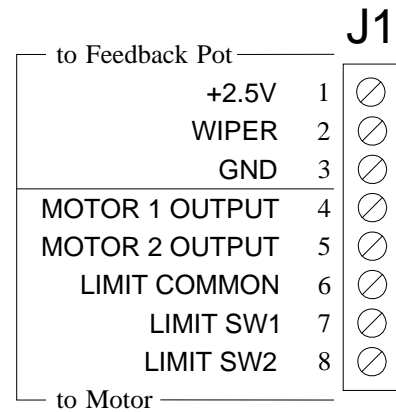

BLOCK DIAGRAM

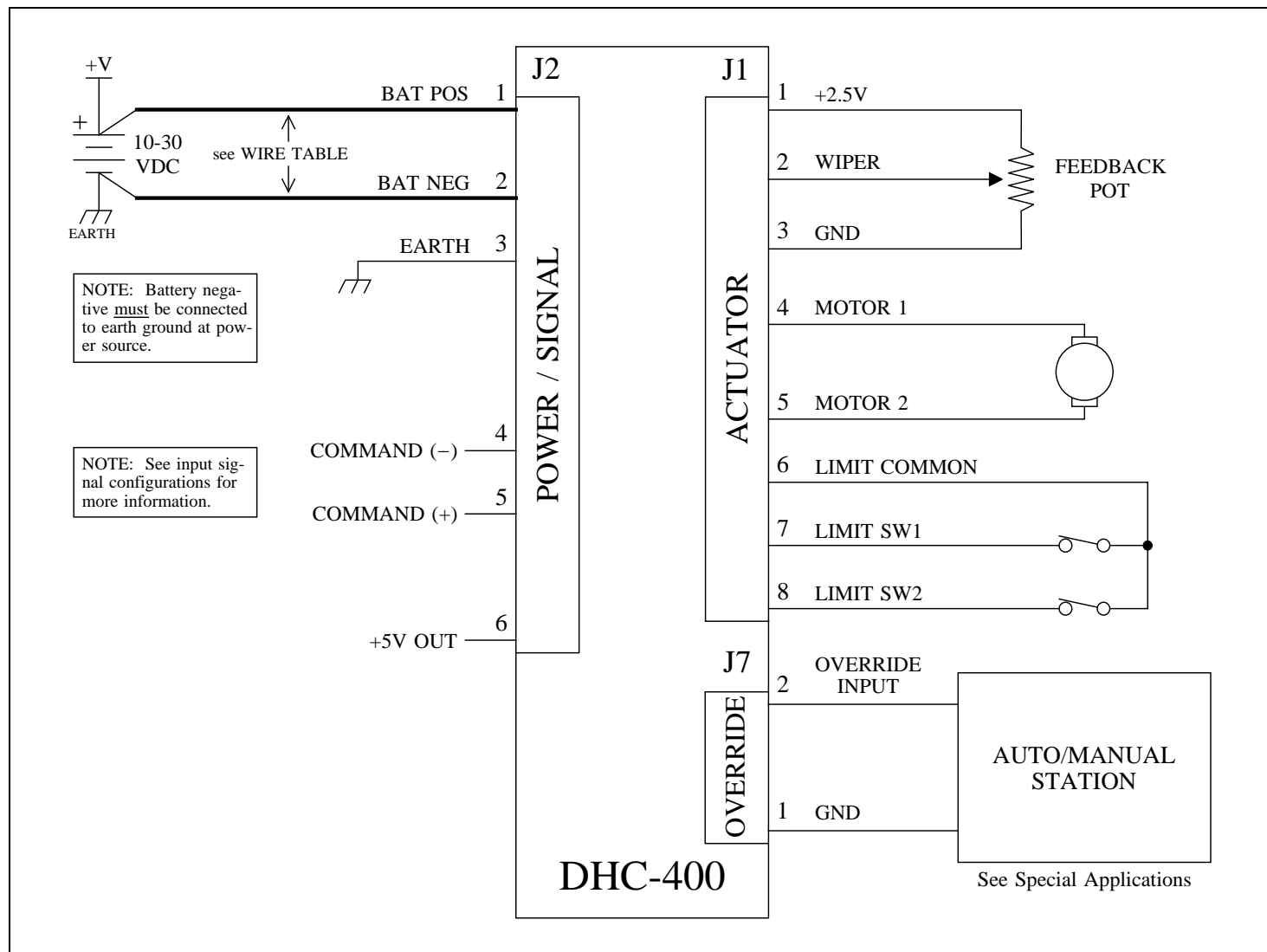

DESCRIPTION

The DHC-400 is rated for motors with up to 60A locked rotor or 10A running currents and has an operating voltage range from 10VDC to 30VDC. The unit is easily mounted with 2 screws and is equipped with removable screw terminals that provide for easy field wiring. The unit's size and mounting allows the DHC-400 to replace the DMC-100 series controllers in most applications with minimal rewiring.

The simple three button control (MODE, ▲, and ▼) allows the user to perform a complete set-up from the unit itself without the need for any instrumentation. The adaptive control feature of the DHC-400 eliminates the need for any calibration steps. In the simplest application, only the *closed* and *open* positions need to be set and the

unit automatically and continuously sets all other parameters when placed in the AUTO mode.

POWER / SIGNAL (J2)

The positive terminal of the DC power source is connected to pin 1 while the negative terminal connects to pin 2. When the DHC-400 is mounted to a metal bracket or directly to the actuator case, pin 3 provides a terminal for an earth ground connection to the actuator body. In applications where the actuator body is non-metallic or is electrically isolated from earth ground, pin 3 must be connected to earth ground to prevent static voltage buildups.

Transferring DC power can be inefficient, therefore care should be taken to use appropriate wire sizes. The size wire required depends on the locked rotor motor current and the length of wire to be used. See the Wire Table for more information.

An appropriate command signal, either 0-5V, 0-10V, 1-5V, 2-10V, or 4-20mA, should be connected to pin 5 (as shown in the Block Diagram) while using pin 4 as the return *signal ground*. See Wiring Diagrams, Input Configurations, for wiring details. The DHC-400 must be configured for the type of command signal that is to be used (see COMMAND TYPE).

Pin 6 of J2 provides an auxiliary +5V output which can be used to connect a command potentiometer. By connecting one end of a potentiometer to pin 6, the other end to pin 4, and the wiper to pin 5, a local control knob can be implemented. Pin 4 will also need to be connected to pin 2 (BAT NEG) for this application.

ACTUATOR (J1)

The actuator motor and feedback potentiometer are connected to J1 as shown in the Block Diagram. The feedback potentiometer wiper must be connected to pin 2, while one end is connected to pin 1 and the other end to pin 3. The **Polarity Detection** feature of the DHC-400 automatically determines which polarity to apply to the motor based on where the *open* and *closed* positions are set; this feature also eliminates the need to rewire the unit for direct or reverse acting applications.

Many actuators include limit switches that are used to turn off the motor when the extreme ends of travel have been reached. Limit switches should be wired to pins 6, 7, and 8 as shown in the Block Diagram. If limit switches are not used, pins 7 and 8 must be connected to pin 6 (note, if pins 7 and 8 are not connected to pin 6, the DHC-400 will not be able to control the motor outputs).

When the ▲ and ▼ buttons are used to control the actuator, the ▲ button will connect pin 4 (MOTOR 1) to BAT POS (J2-1) and pin 5 (MOTOR 2) to BAT NEG (J2-2) as long as pin 7 (LIMIT SW1) is connected to pin 6 (LIMIT COMMON). Likewise, the ▼ button will connect pin 5 to BAT POS and pin 4 to BAT NEG as long as pin 8 (LIMIT SW2) is connected to LIMIT COMMON. Since pins 4 and 5 are alternately connected to BAT POS (J2-1) and BAT NEG (J2-2), care should be taken not to connect the motor output pins to any other terminals. See MANUAL/FB POT CAL for more details.

The DHC-400 provides a dynamic braking feature that can eliminate the need for a separate brake. When the DHC-400 turns off the motor outputs, pins 4 and 5 are internally connected to the BAT NEG pin (J2-2); this has the effect of shorting the motor leads together, thus braking the motor motion. When power is removed from the DHC-

400, the electronic braking feature is disabled. In some applications, a brake is required for mechanical reasons, such as avoiding back driving the motor; the DHC-400 is suitable for powering most brakes, however, consult the actuator manufacturer for more information.

OVERRIDE (J7)

J7 provides a simple 2-wire connection that can override the DHC-400 to perform a variety of external control functions. Using an appropriate interface module, commonly used auto/manual station switches are easily implemented with low voltage/low current switches. See Special Applications for more details. The factory installed jumper between pins 1 and 2 enables normal operation of the DHC-400 and must be installed if the external override functions are not used.

MODE

The MODE button is used to select the desired function of operation. When the MODE button is pressed, the unit will switch to the next function and the appropriate LED indicator will turn on to let the user know which function is selected. Except for the MANUAL/FB POT CAL mode, the associated mode indicator will be steady on; for some of the modes other indicators will flash to indicate specific settings associated with the mode. Each of the modes are described in more detail in the following sections.

If a 0-5V or 0-10V command signal is used, the LOSS OF COMMAND function cannot be used. The MODE button will skip over the LOSS OF COMMAND mode when the unit is configured for a 0-5V or 0-10V command signal (see COMMAND TYPE). When the OVERRIDE mode is enabled (see OVERRIDE MODE), the MODE button is disabled and the Manual/FB Pot Cal indicator will turn on steady.

ADJUST UP (▲) and ADJUST DOWN (▼)

The adjust up (▲) and adjust down (▼) buttons are used to adjust the setting of any given function. When a function is selected by the MODE button, the adjust buttons will affect that function only. Note, that the AUTO mode does not have any adjustable settings, and therefore, the adjust up (▲) and adjust down (▼) buttons have no effect. Also, the adjust buttons are disabled in the OVERRIDE mode.

OVERRIDE MODE

The OVERRIDE mode is not selected by the MODE button and can be enabled at anytime by connecting a resistance greater than 250 ohms to the Override Input (J7 pin 1 and pin 2). While the OVERRIDE mode is enabled, the MODE button and adjust buttons are disabled, and the Manual/FB Pot Cal indicator will turn on steady to indicate that the unit is being controlled by the Override Input. Shorting J7 pin 1 to pin 2 returns the unit to normal operation and the previously selected mode.

Controlling the DHC-400 from the Override Input is accomplished by connecting a specific resistance to select a specific operation. The table below defines the operations and their associated resistance. See Special Applications for details on using the Override Input for an Auto/Manual Station.

RESISTANCE	OPERATION
> 4.3K ohms	OFF
3.3K ohms $\pm 5\%$	LATCH
2K ohms $\pm 5\%$	OPEN
1.2K ohms $\pm 5\%$	CLOSE
510 ohms $\pm 5\%$	STOP

The OPEN function will operate the motor in the *open* direction as set by the OPEN mode, while the CLOSE function operates the motor in the *closed* direction as set by the CLOSE mode. The LATCH function will maintain the previously selected function; this allows momentary switches to be used for the OPEN and CLOSE functions. The OFF and STOP functions turn the motor off, which also unlatches the OPEN or CLOSE functions.

Note that the OPEN and CLOSE functions may work in reverse until the *open* and *closed* positions are set by the OPEN and CLOSE modes. The DHC-400 will automatically turn the motor off when the *open* or *closed* positions are reached. However, if a feedback fault occurs (see FAULT INDICATORS), the motor will be turned on for a period of 15 minutes in the selected direction. For this reason, limit switches should be used when using the OVERRIDE mode, and should be set to a position acceptable for the application. The 15 minute period can also be terminated using the OFF or STOP function.

The motor is also automatically turned off if the DHC-400 detects a stall (see STALL DETECTION). An OPEN or CLOSE operation can be attempted again after switching to the OFF, LATCH, or STOP functions first.

The motor is also turned off if a motor current trip is detected (see TRIP SETTING). If the trip occurred during an OPEN operation, the OPEN operation is disabled until the trip condition is corrected. The CLOSE operation may be used to attempt to clear the trip condition (by causing a certain amount of motion in the *closed* direction). Likewise, if a trip occurs during a CLOSE opera-

tion, the OPEN operation can be used for clearing the trip. If a trip occurs in both directions (i.e., before the first trip can be cleared), the trip can only be cleared by a mechanical override mechanism, or by using the MANUAL mode from the DHC-400 front panel, or by powering the DHC-400 down and back up.

AUTO

The AUTO function is the normal mode of operation for the DHC-400; all the other functions are used to set up the unit. While in AUTO, the unit can be controlled by various external signals, some of which can be selected by the COMMAND INPUT function. When the unit is not in the AUTO mode, all external control signals described below will be disabled.

Once the *open* and *closed* positions have been set, the AUTO mode will control the position of the actuator according to the command input signal. For an input signal of 0V (for 0-5V or 0-10V input), 1V (for 1-5V input), 2V (for 2-10V input), 4.0 mA (for 4-20mA input), or 0% (for a Digital input), the DHC-400 will position the actuator to the *closed* position as set by the user. Conversely, an input of 5V, 10V, 20mA, or 100% will position the actuator to the defined *open* position.

When the DHC-400 is configured to use a 0-5V, 0-10V, 1-5V, 2-10V, or 4-20mA command, the command signal should be connected to the appropriate pins on J2. When the DHC-400 is configured for a Digital command type, an appropriate communications option module must be installed. A communications module may be installed when using one of the analog command types and can be used to override the analog command. The AUTO indicator will flash whenever the unit is being controlled by the communications module.

MANUAL/FB POT CAL

The MANUAL/FB POT CAL function allows manual operation of the actuator by using the adjust buttons (\blacktriangle and \blacktriangledown) without affecting any other settings within the DHC-400. When the \blacktriangle button is pressed, the MOTOR 1 (J1-4) output is connected to BAT POS (J2-1), and the MOTOR 2 (J1-5) output is connected to BAT NEG (J2-2). The \blacktriangledown button connects MOTOR 1 to BAT NEG and MOTOR 2 to BAT POS. Whether the actuator moves toward the *open* or *closed* position depends on which motor wire is connected to J1-4 and J1-5.

The FB POT CAL feature provides an indication of the feedback potentiometer's setting. When the MANUAL/FB POT CAL function is selected, the Manual/FB Pot Cal indicator will turn on - it may flash or be on

steady, depending on the actuator position. The indicator will be on steady whenever the DHC-400 detects that the feedback potentiometer is at midrange of its rotation. As the actuator moves, causing the feedback potentiometer to move away from midrange, the indicator will begin to flash, and the indicator will flash at a decreasingly slower rate as the actuator moves further away from midrange.

By using the adjust buttons to position the actuator to midstroke (half way point between the desired *open* and *closed* positions), the feedback potentiometer can then be adjusted until a steady light occurs. This insures that the feedback potentiometer has maximum range to reach the *open* and *closed* positions.

CLOSE

The CLOSE function is used to set the desired *closed* position; however, prior to doing this, the feedback potentiometer should be checked for optimum position (see MANUAL/FB POT CAL), and the limit switches should be set outside of the operating range (see LIMIT SWITCHES). In the CLOSE function, the adjust buttons are used to set the actuator to any desired position, and upon pressing the MODE button (to select the next function, OPEN), the DHC-400 will retain the setting as the defined *closed* position.

Upon selecting the CLOSE function, the DHC-400 will begin moving the actuator to the previously set *closed* position; it is not necessary to make an adjustment if the unit has been previously set to the desired position. A command signal input of 0V, 1V, 2V, 4mA, or 0% automatically corresponds to the defined *closed* position.

OPEN

The OPEN function works the same way as the CLOSE function with the exception that the adjust buttons are used to set the desired *open* position. As with the CLOSE function, upon selecting the OPEN function, the actuator will move to the previously set *open* position. Once the desired position is set, the DHC-400 will automatically associate a command signal input of 5V, 10V, 20mA, or 100% to the *open* position.

AUX CLOSE OUTPUT

The AUX CLOSE OUTPUT function is used to set an optional output setting that is associated with the *closed* position - an appropriate relay option module is required to use this output. The adjust buttons are used to set the actuator to a desired position. Whenever the actua-

tor position falls between the defined *closed* position and the Aux Close position, the Aux Close Output indicator will flash. Additionally, the DHC-400 will turn on a relay output on the optional relay module - the output can be used to drive an alarm or merely act as an auxiliary limit switch.

Upon selecting the AUX CLOSE OUTPUT function, the DHC-400 will begin moving the actuator to the previously set position. It is not necessary to make an adjustment if the unit has been previously set to the desired position.

AUX OPEN OUTPUT

The AUX OPEN OUTPUT function is used to set an optional output setting that is associated with the *open* position - an appropriate relay option module is required to use this output. The adjust buttons are used to set the actuator to a desired position. Whenever the actuator position falls between the defined *open* position and the Aux Open position, the Aux Open Output indicator will flash. Additionally, the DHC-400 will turn on a relay output on the optional relay module - the output can be used to drive an alarm or merely act as an auxiliary limit switch.

Upon selecting the AUX OPEN OUTPUT function, the DHC-400 will begin moving the actuator to the previously set position. It is not necessary to make an adjustment if the unit has been previously set to the desired position.

COMMAND TYPE

The COMMAND TYPE function is used to configure the command signal input for either 4-20mA, 1-5V, 0-5V, 0-10V, 2-10V, or Digital so as to match the type of command signal being used. Upon selecting the COMMAND TYPE function, the Command Type indicator will turn on steady, while the indicator for the selected type will flash. Use the adjust buttons (▲ or ▼) to select the desired input type. The selection will be saved when the MODE button is pressed, which will also advance the unit to the LOSS OF COMMAND function.

LOSS OF COMMAND

When using 1-5V, 2-10V, 4-20mA, or a Digital input type for the command signal, the DHC-400 will detect when the command signal is lost or out of range. A loss of command condition is detected whenever the input is disconnected, the input becomes less than 0.75V (for 1-5V input), 1.5V (for 2-10V input) or 3mA, or the input is

connected backwards. An out of range condition is detected whenever the input becomes greater than 5.25V (for 1-5V input), 10.5V (for 2-10V input), or 21mA. If the DHC-400 detects a loss of command, a fault will be indicated (see FAULT INDICATORS), and the actuator will be moved to one of three preset positions: the *open* position, the *closed* position, or the position last attained prior to losing the command signal. The LOSS OF COMMAND function is used to set the desired default position.

When the LOSS OF COMMAND function is selected, the adjust buttons are used to set the default position. The DHC-400 indicates the selected default setting by flashing the Open function indicator for the *open* default position, or it will flash the Close function indicator for the *closed* default position. When neither indicator is on, then the "last position" default is selected.

When a 0-5V or 0-10V command signal is used, a loss of command signal cannot be reliably detected. Therefore, if the unit is configured for a 0-5V or 0-10V command signal (see COMMAND TYPE), the MODE button will not select the LOSS OF COMMAND function. However, the DHC-400 can detect when a 0-5V or 0-10V command signal is out of range (i.e., greater than 5.25V or greater than 10.5V) or connected backwards. When an out of range condition is detected for a 0-5V or 0-10V input, the motor is turned off (leaving the actuator in its "last position") and a fault will be indicated (see FAULT INDICATORS).

POSITION OUT CAL

The POSITION OUT CAL function is used to calibrate an optional feedback transmitter output. An appropriate transmitter option module is required to use this feature. When the POSITION OUT CAL function is first selected (by pressing the MODE button while in the LOSS OF COMMAND function), the CLOSE indicator will flash, and the current associated with the *closed* position will appear at the option module output. If desired, the output can be adjusted (using the adjust buttons) to any value from 4 to 20mA. The new setting is saved when the MODE button is pressed.

Pressing the MODE button will leave the unit in the POSITION OUT CAL function except that the OPEN indicator will flash, and the output current associated with the *open* position will appear at the option module output. Like the *closed* setting, the output can be adjusted to any current from 4 to 20mA. The new setting is saved when the MODE button is pressed, which also selects the AUTO mode.

FAULT INDICATORS

The DHC-400 detects various fault conditions that prohibit the unit from controlling the actuator. A combination of the three Fault indicators (red, yellow, and green) will turn on or flash to indicate a specific detected fault. If an appropriate relay option module is installed, the Fault relay output on the option module will turn off (indicating a fault) when any of the Fault indicators turn on or flash. A communications option module can also read the specific conditions causing a fault. Note that a fault condition DOES NOT disable the motor outputs when manually controlling the actuator with the adjust buttons; while useful for troubleshooting, care should be exercised when operating the motor under a fault condition. The OVERRIDE mode can also operate the motor when a fault condition exists - see OVERRIDE MODE for details.

Note that the indicators may not indicate all the fault conditions that may exist. This means that when the indicated fault is corrected, the unit may display another fault that has not been corrected. The table below provides a summary of the Fault indications which is followed by a description of each fault.

RED	YEL	GRN	FAULT
flash	OFF	OFF	Low Battery Voltage
flash	flash	OFF	Motor 1 Stall
flash	OFF	flash	Motor 2 Stall
flash	flash	flash	Double Stall
flash	ON	OFF	Motor 1 Current Trip
flash	OFF	ON	Motor 2 Current Trip
flash	ON	ON	Double Current Trip
ON	OFF	OFF	Battery Over Voltage
ON	flash	OFF	Motor 1 No Motion
ON	OFF	flash	Motor 2 No Motion
ON	flash	flash	Double No Motion
OFF	OFF	flash	Feedback Alarm
OFF	flash	OFF	Loss of Command
OFF	ON	OFF	Command Out of Range
OFF	flash	flash	Feedback Alarm and Loss of Command
OFF	ON	flash	Feedback Alarm and Command Out of Range

Low Battery Voltage - When the DHC-400 detects that the battery/power supply voltage connected to BAT POS (J2-1) and BAT NEG (J2-2) drops below 10V, the motor outputs are turned off and the DHC-400 suspends all other operations until the voltage returns to 10V or more. However, the Low Battery Voltage fault indication will maintain for 3 seconds after voltage returns. Since DC motors

present a large load (from in-rush currents) when turned on, a weak battery or insufficient power supply may experience a short voltage drop below 10V until the motor begins to move. Therefore, the Low Battery Voltage indication provides warning of batteries in need of recharge or power supplies that have insufficient current for the application.

Motor 1 Stall - A *stall* condition is detected when no actuator motion is detected while the Motor 1 output is turned on and drawing more than 0.5A of motor current. The fault condition will disable the Motor 1 output only, and the fault is cleared when the DHC-400 detects a motion greater than 1.5° in either direction. The fault can be cleared if 1) the command signal commands a Motor 2 operation, 2) manual operation with the adjust buttons results in a motion greater than 1.5°, or 3) a mechanical manual override forces the 1.5° motion, provided the mechanical motion is monitored by the feedback pot.

Motor 2 Stall - A *stall* is detected when no actuator motion is detected while the Motor 2 output is turned on and drawing more than 0.5A of motor current. The fault can be cleared in the same manner as previously described for a Motor 1 Stall.

Double Stall - If the DHC-400 detects a *stall* condition in both directions, both motor outputs will be disabled. The command signal cannot clear this condition; only manual operation or a mechanical override can clear the fault. Alternatively, the DHC-400 can be powered off and then on to temporarily clear the fault; however, this practice should be avoided without permanently correcting the cause of such a fault.

Motor 1 Current Trip - A *current trip* fault is detected when the motor current exceeds the current trip setting (see TRIP SETTING) while the Motor 1 output is turned on. The fault can be cleared in the same manner as previously described for a Motor 1 Stall. NOTE: Successive attempts with manual operation using the adjust buttons can exceed the torque limit set by the Trip Setting.

Motor 2 Current Trip - A *current trip* fault is detected when the motor current exceeds the current trip setting (see TRIP SETTING) while the Motor 2 output is turned on. The fault can be cleared in the same manner as previously described for a Motor 1 Current Trip.

Double Current Trip - If the DHC-400 detects a *current trip* fault in both directions, both motor outputs will be disabled. The fault can be cleared in the same manner as previously described for a Double Stall.

Battery Over Voltage - Other inductive loads (such as motors or solenoids) sharing the battery/power supply connected to BAT POS (J2-1) and BAT NEG (J2-2) can generate short transient voltages that may cause the supply voltage to exceed 30V. To prevent damage to the DHC-400 or the actuator motor, the motor outputs are turned off whenever the supply voltage exceeds 30V. Upon detecting a voltage above 30V, the Battery Over Voltage fault indication will turn on and will maintain for 3 seconds after voltage returns. If an over voltage condition lasts less than 1 second, the Fault relay output will not turn off. If the Fault relay output turns off (indicating an over voltage lasting longer than 1 second), the output will turn back on when the voltage returns to 30V or less. Note, earlier versions of the DHC-400 may not have this feature. Contact Peaktronics, Inc. for more information.

WARNING! Exposing the DHC-400 to frequent or continuous voltages above 30V can damage the unit. The user should take steps to suppress or eliminate possible supply voltage conditions above 30V.

Motor 1 No Motion - A *no motion* fault is detected when no actuator motion is detected while the Motor 1 output is turned on and drawing less than 0.5A of motor current. The fault can be cleared in the same manner as previously described for a Motor 1 Stall. A *stall* usually indicates a heavy mechanical load or stall, while a *no motion* fault usually indicates a broken motor wire or disengaged feedback pot. Note that a *stall* cannot be detected in applications using very small motors (locked rotor currents less than 0.5A); only a *no motion* fault can be detected.

Motor 2 No Motion - A *no motion* fault is detected when no actuator motion is detected while the Motor 2 output is turned on and drawing less than 0.5A of motor current. The fault can be cleared in the same manner as previously described for a Motor 1 Stall. A *no motion* fault differs from a *stall* as previously describe for a Motor 1 No Motion fault.

Double No Motion - If the DHC-400 detects a *no motion* fault in both directions, both motor outputs will be disabled. The fault can be cleared in the same manner as previously described for a Double Stall.

Feedback Alarm - A fault condition is detected whenever the feedback signal is out of range (that is, less than 5% of the potentiometer value or more than 95% of the potentiometer value), or when any of the potentiometer connections are broken. Normal operation resumes when the potentiometer is reconnected or back in range.

Loss of Command - If the command signal is disconnected, the fault indication will remain on until the signal is reconnected. See LOSS OF COMMAND for details.

Command Out of Range - If the command signal goes out of range, the fault indication will remain on until the signal is back in range. See LOSS OF COMMAND for details.

LIMIT SWITCHES

The actuator's limit switches should be connected to J1 as described in ACTUATOR (J1) - also see OUTLINE and BLOCK DIAGRAM. The limit switches must be closed throughout the operating range from *closed* to *open*. When Limit Switch 1 opens, Motor 1 operations are disabled. Likewise, when Limit Switch 2 opens, Motor 2 operations are disabled.

Note that the actuator's limit switches should be set outside of the operating range set by the CLOSE and OPEN functions. Limit switches exhibit wide variations, and the DHC-400 can position the actuator more precisely at *closed* and *open* than the limit switches. A limit switch serves better as a fail safe device.

After setting the *open* and *closed* positions, the DHC-400 automatically determines which limit switch is associated with *open* and *closed*. When a limit switch is reached, the appropriate indicator light (CLOSE or OPEN) will flash. If an appropriate relay option module is installed, the Fault relay output on the option module will turn off (indicating a fault) when either of the limit switches is reached.

TRIP SETTING

The **Trip Setting** is used to limit the motor current and is set using the TRIP ADJUST pot (see OUTLINE) as shown below.

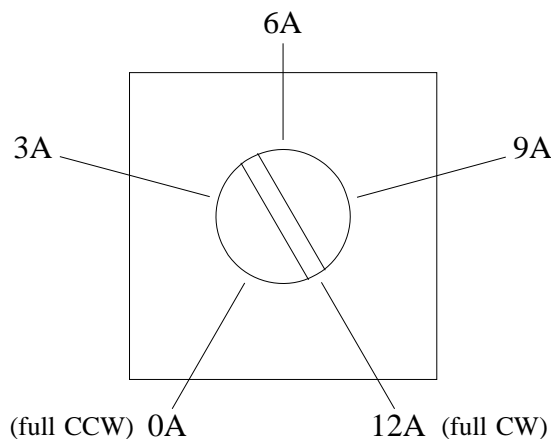

The setting should be adjusted to a comfortable level above the running current expected for the actuator and its load. When the motor current exceeds the trip setting, the motor is turned off and a fault condition is indicated (see FAULT INDICATORS).

While the **Electronic Surge Limiting** feature of the DHC-400 reduces the high in-rush currents during motor starts, the trip setting is used to reduce the current required from the battery/power supply when the motor stalls or encounters an excessive load. Without the trip setting, a costly high capacity battery/power supply would be needed to avoid collapse of the battery/power supply voltage. The combination of the trip setting and electronic surge limiting allows the use of a more moderate battery/power supply and smaller gauge wires for a given length (see WIRE TABLE).

The trip setting essentially performs the same function as commonly used torque switches. However, it should be noted that the actuator and valve components (gears, couplings, seats, etc.) also place a load on the motor. These components will vary with temperature and age, and therefore the torque on the load will vary accordingly.

STALL DETECTION FEATURE

The **Stall Detection** feature of the DHC-400 detects when there is no motion after a certain amount of time while the motor is turned on (see FAULT INDICATORS). This condition can arise if the motor's stall current is less than the current trip setting (see TRIP SETTING). If the motor current is greater than 0.5A when no motion is detected, a *stall* fault is indicated.

When one of the motor wires is disconnected, no motion will be detected, but the motor current will be zero. Therefore, if the motor current is less than 0.5A when no motion is detected, a *no motion* fault is indicated.

If the feedback pot is mechanically disengaged, no motion will be detected, but the motor current will be the normal running current. Therefore a *stall* or a *no motion* fault may be indicated, depending on whether the running current is greater or less than 0.5A.

ELECTRONIC BRAKE FEATURE

The **Electronic Brake** feature of the DHC-400 provides highly reliable and accurate braking of the motor, and it is a key element in achieving high resolution. A mechanical brake can still be implemented without interfering with the DHC-400 operation. The **Adaptive Control** feature of the DHC-400 automatically compensates for changes in a mechanical brake's performance due to temperature or age.

Mechanical brakes can be useful for providing a holding brake in the event power to the actuator is lost. However, mechanical brakes require time to release on motor start up, and this may cause an increased surge current that counteracts the **Electronic Surge Limiting** feature. Also, a mechanical brake may not release at lower voltages, in which case a stall or current trip fault may occur.

The **Electronic Brake** feature remains on as long as the DHC-400 is powered. This could make a mechanical override mechanism difficult to turn. For this reason, the electronic brake is disabled when the DHC-400 is placed in the Override Mode via J7 (see Special Applications).

CAUTION! When using the DHC-400 with a spring return actuator, the return spring can generate high electrical energies while back driving the motor that can damage the DHC-400 motor outputs. In this application, the motor must be disconnected (usually with a relay) from the DHC-400 during a spring return operation.

DUTY CYCLE CONTROL FEATURE

The **Duty Cycle Control** feature of the DHC-400 allows the actuator to be safely used when a process becomes unstable, a control loop is not properly set, or when the motor is subjected to excessive loading. The DHC-400 accurately monitors the relative heating of the motor and automatically duty cycles the unit at a safe level.

The **Duty Cycle Control** feature allows continuous operation of the motor until it detects an excess heat build up in the motor. At that time, duty cycle operation is automatically enabled and continues until the motor cools enough to resume continuous operation. The duty cycle period is approximately 2 seconds with an on time that automatically varies depending on the heating of the motor. While this operation slows down the actuator's operation, it does not impact the resolution performance of the DHC-400, and it allows control of the process to be maintained without damage to the motor.

OPTION MODULES

Various option modules can be plugged into the DHC-400 option module connector, J3. Option modules provide additional features such as position feedback signals, auxiliary switch outputs, or digital communications.

Contact the factory for the latest available modules. Refer to the diagram below for instructions on installing an option module.

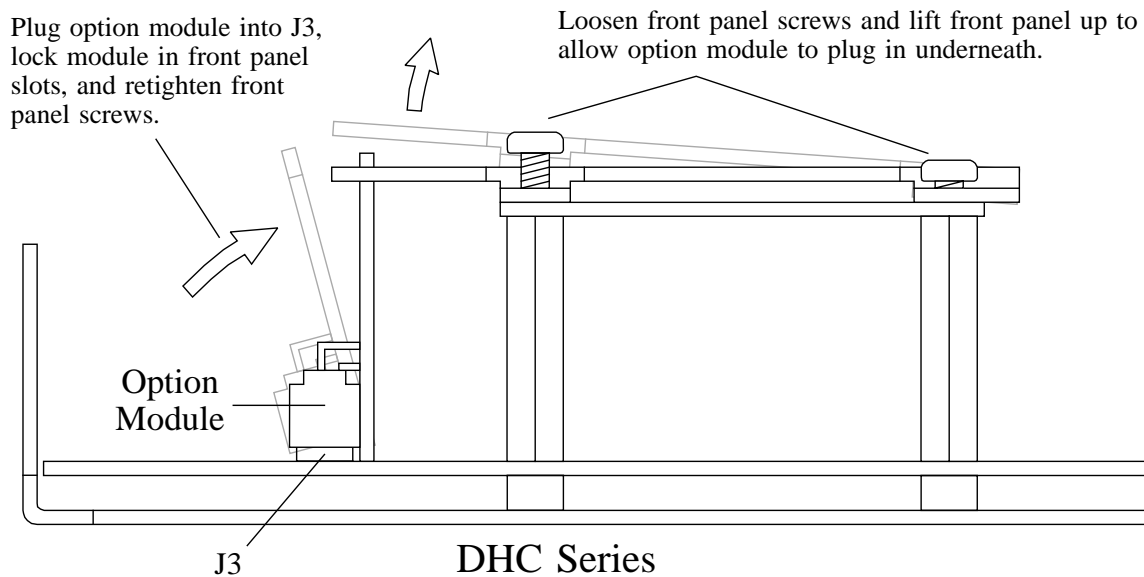

Installing an Option Module

SPECIFICATIONS

POWER REQUIREMENTS

Operating Voltage: 10 to 30 VDC
Operating Current, typical: 70mA (not including option module)
Fuse Type: 10A TR5 Time Lag 374 (replaceable)

COMMAND SIGNAL INPUT

Common Mode Voltage (both inputs): -9 to +30 VDC
Input Impedance
 10.25K ohms (1-5 VDC, 0-5 VDC, 0-10 VDC, 2-10 VDC Input)
 250 ohms $\pm 1\%$ (4-20 mA Input)
Loss of Command threshold
 < 0.75V (1-5 VDC input)
 < 1.5V (2-10 VDC input)
 < 3mA (4-20mA input)
Command Out of Range threshold
 > 5.25V (0-5 VDC, 1-5 VDC input)
 > 10.5V (0-10 VDC, 2-10 VDC input)
 > 21mA (4-20mA input)

FEEDBACK SIGNAL INPUT

Input Voltage: 0 to 2.5 VDC
External Feedback Potentiometer: 1K ohm

COMMAND POTENTIOMETER POWER OUTPUT (J2-6)

+5V OUT: 20mA maximum
NOTE: *Do not* connect this output to other power supplies.

DC MOTOR OUTPUTS

Maximum Running Current: 10 A
Motor Current Trip: 0 to 12 A (adjustable)
Motor Current Measurement Resolution: 85mA typical

ENVIRONMENTAL

Operating Temperature Range: 0 °C to 60 °C
Storage Temperature Range: -40 °C to 85 °C
Relative Humidity Range: 0 to 90 % (noncondensing)

WIRING DIAGRAMS

Output Configurations

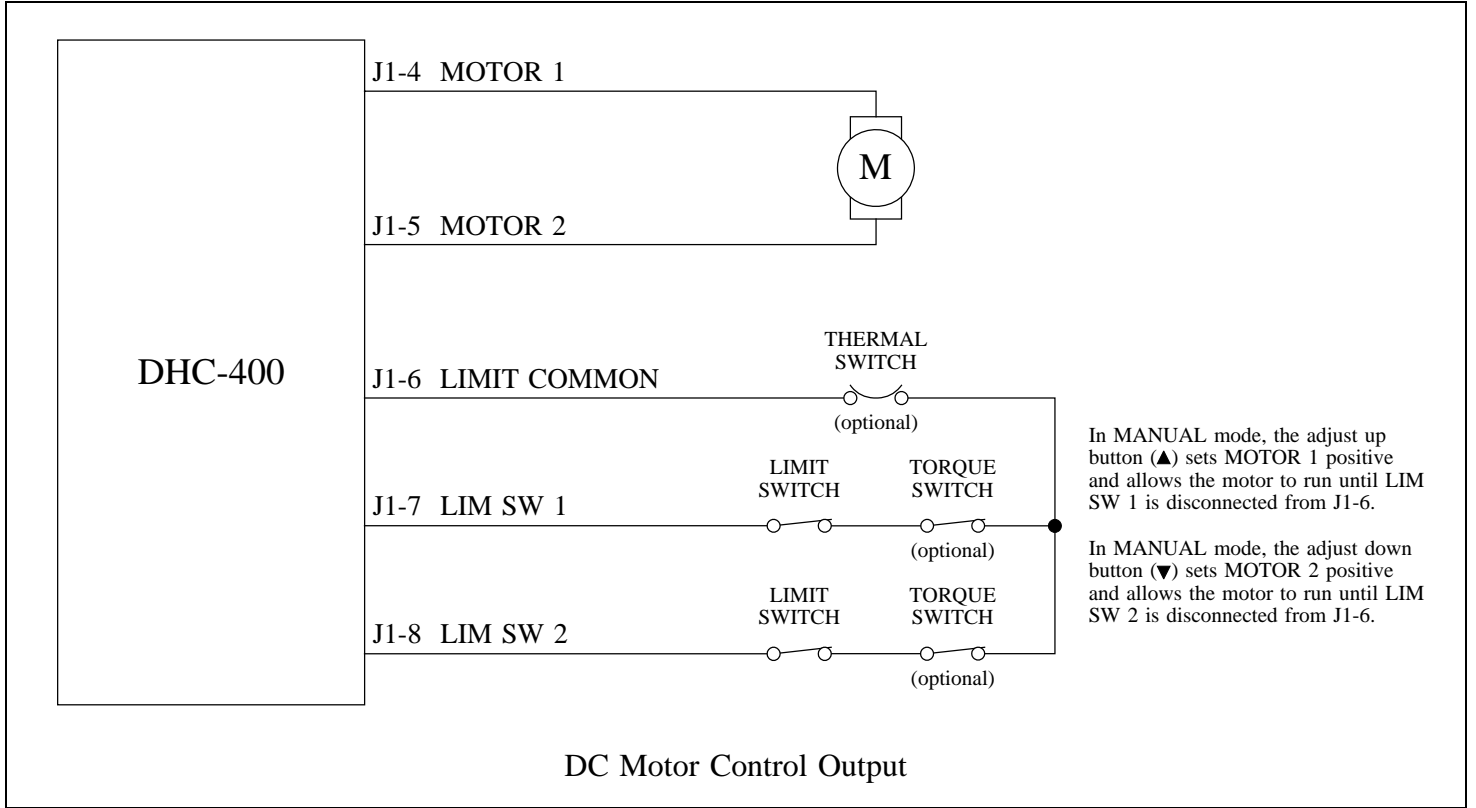

WIRING DIAGRAMS

Input Signal Configurations

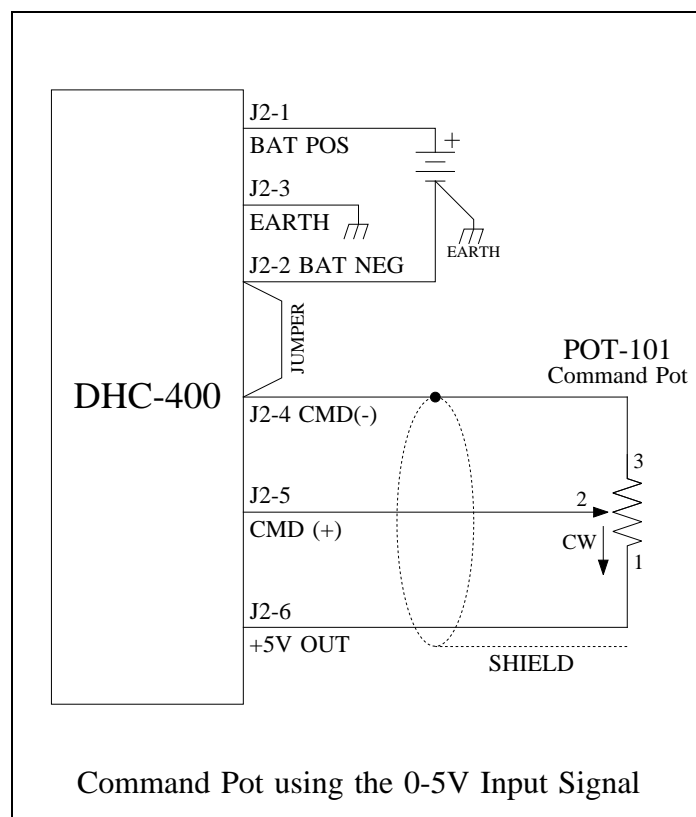
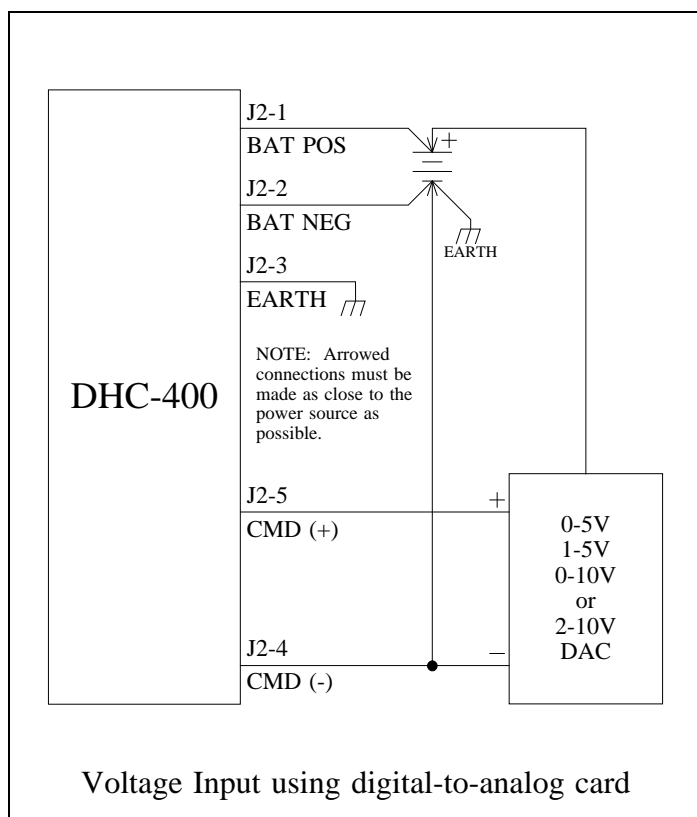
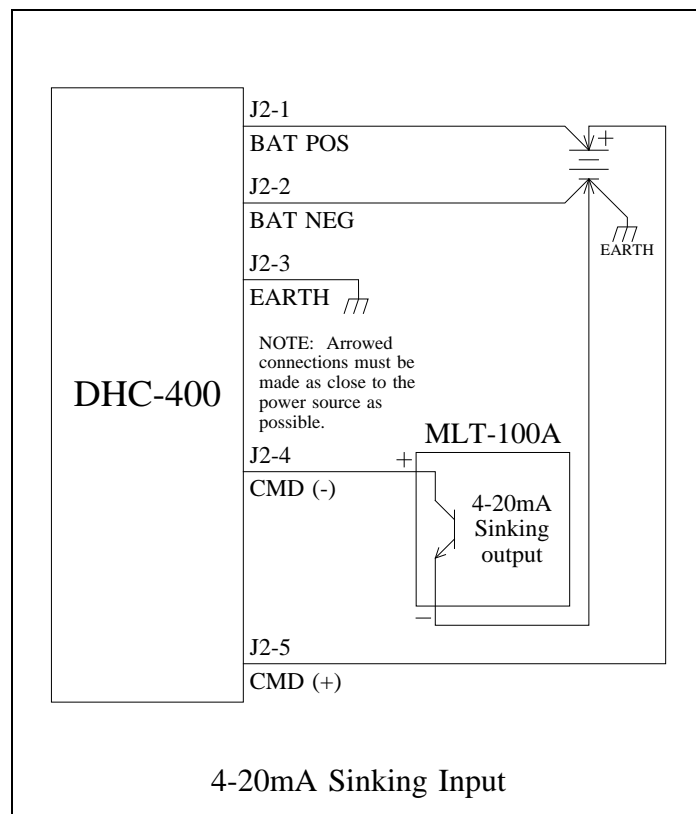
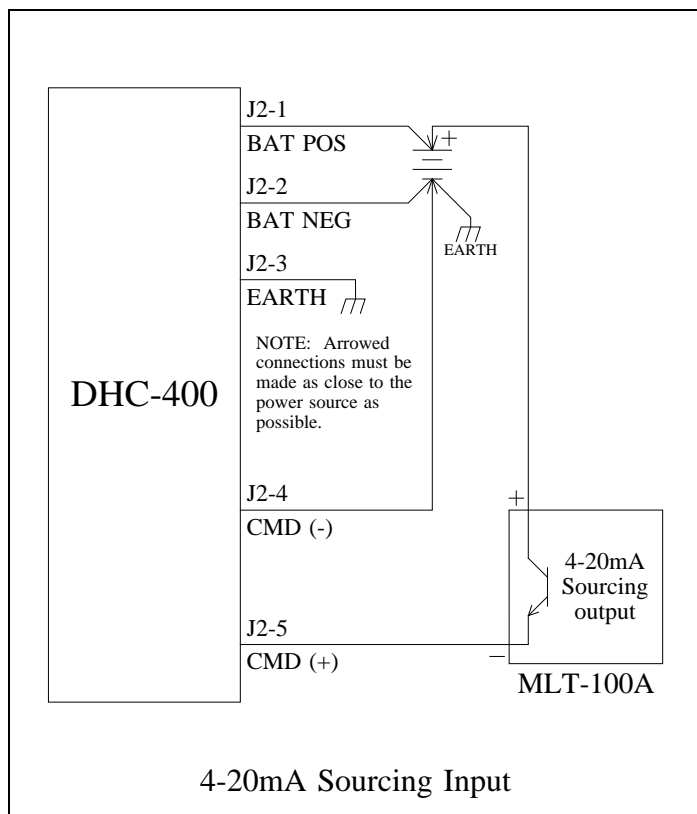

WIRING DIAGRAMS

Special Applications

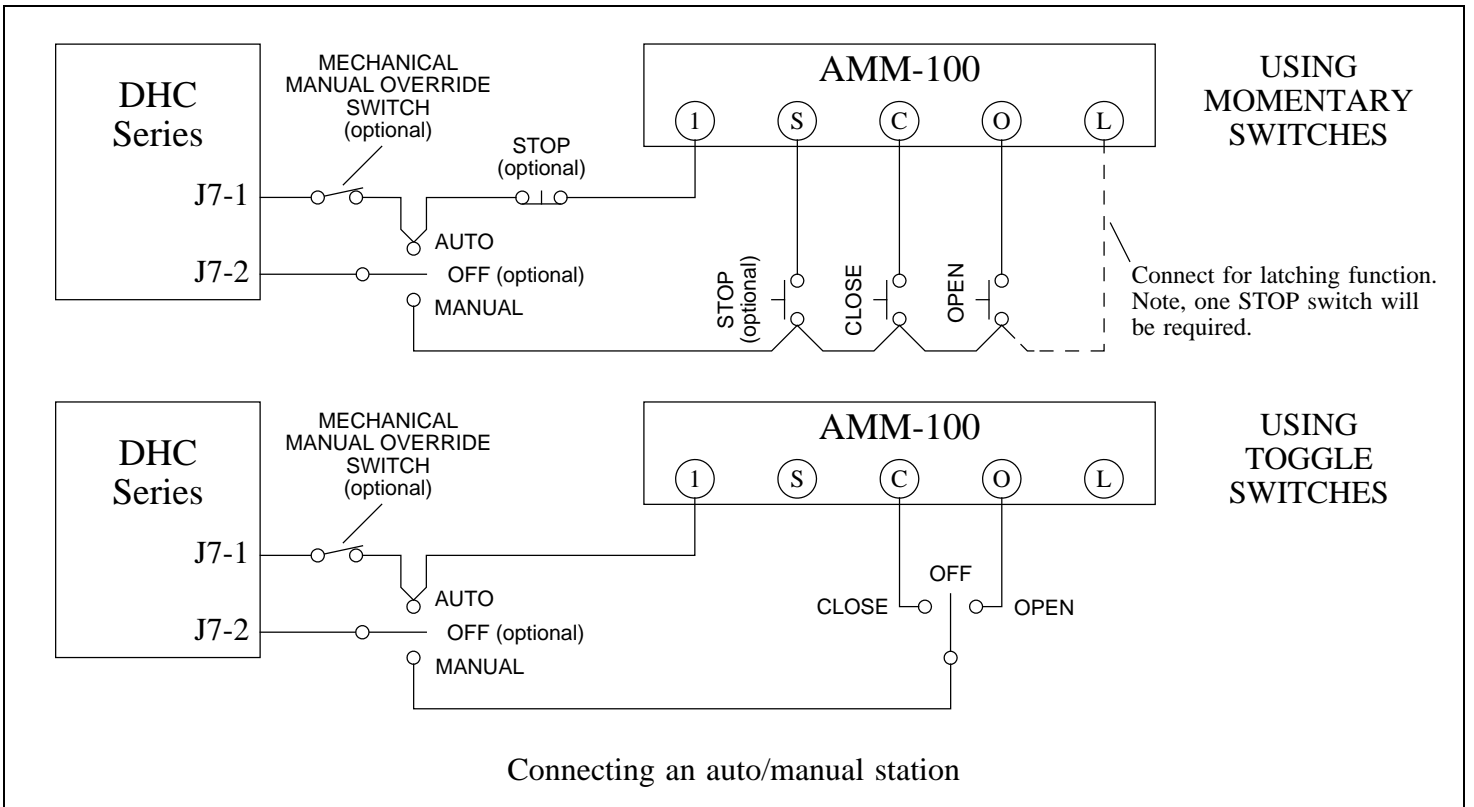
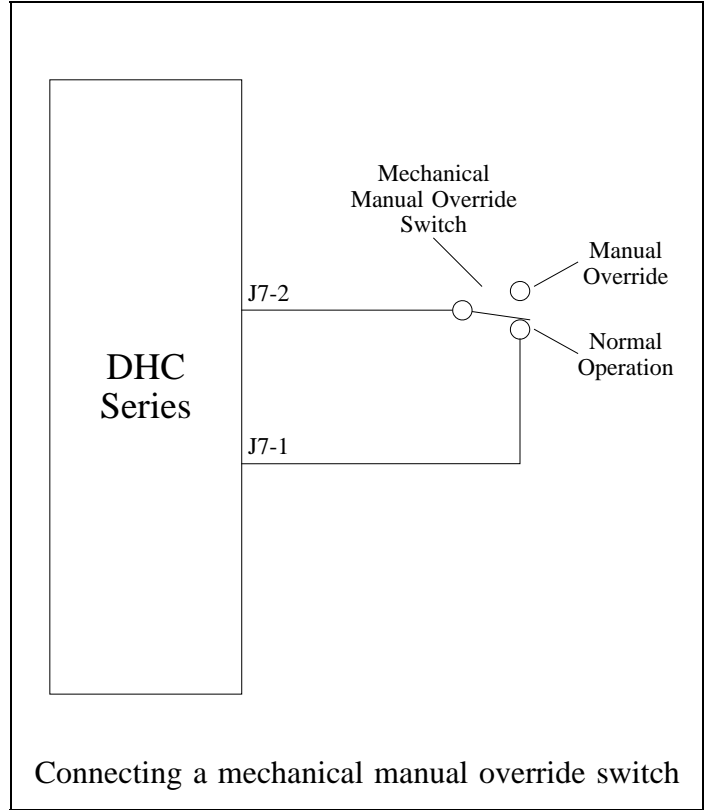
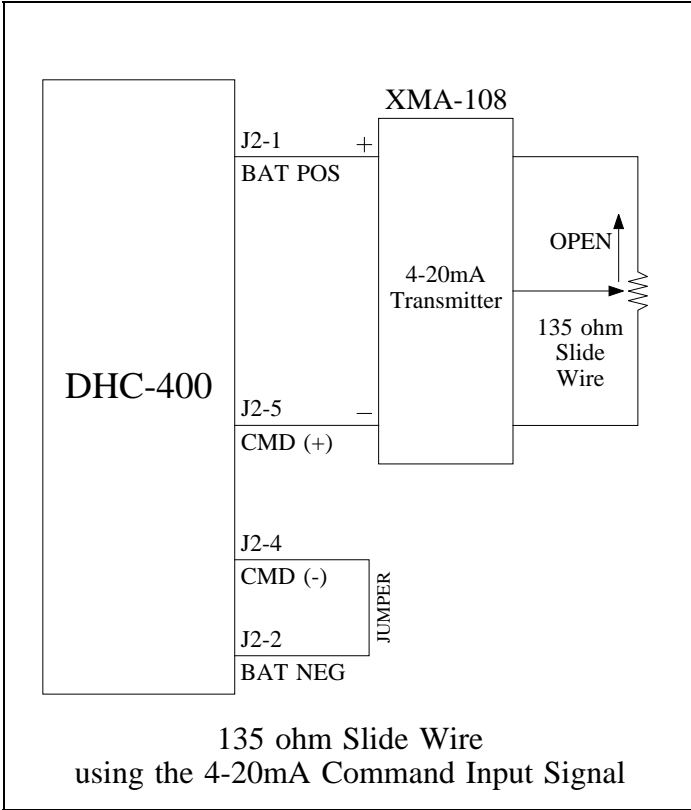

WIRING DIAGRAMS

Special Applications (continued)

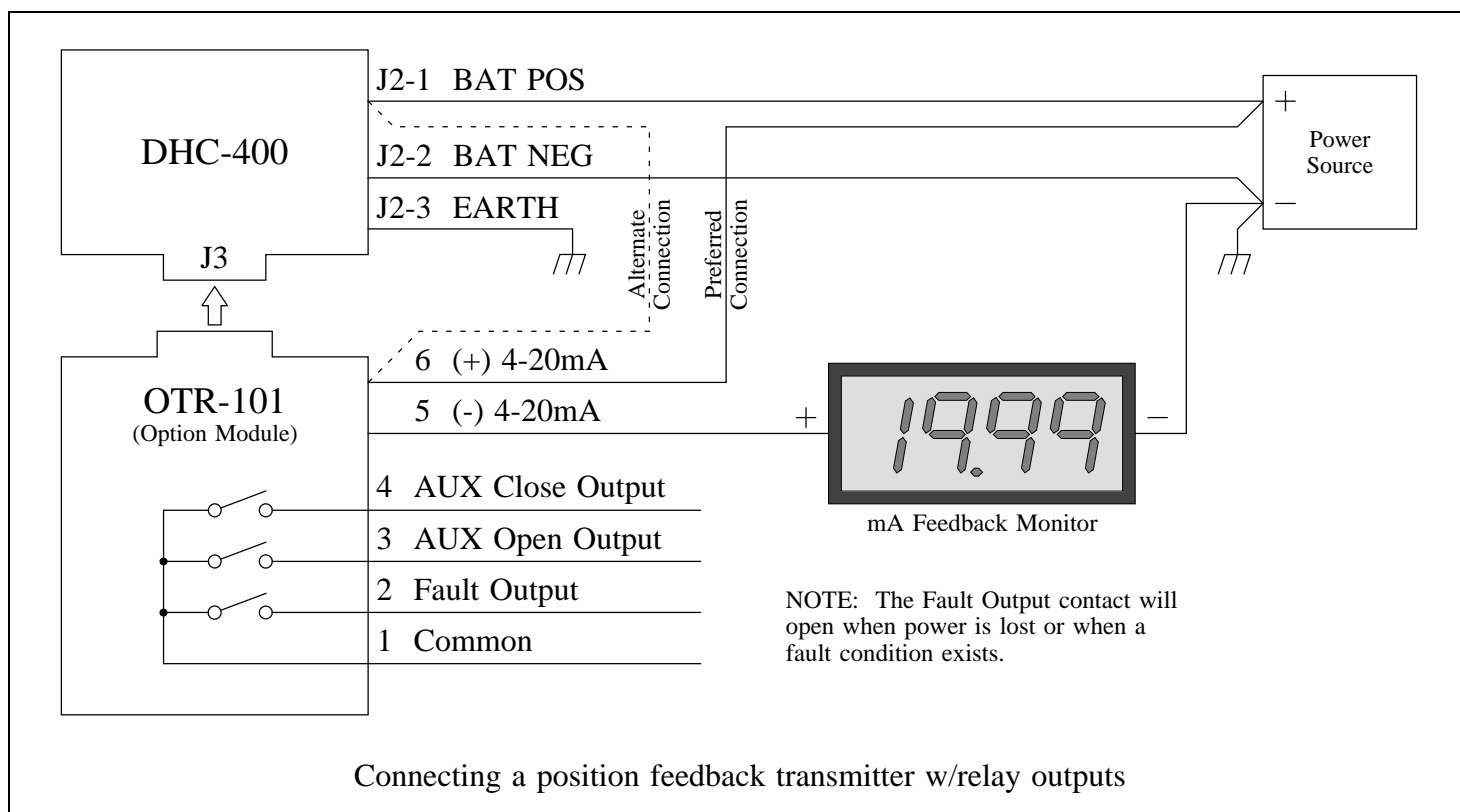
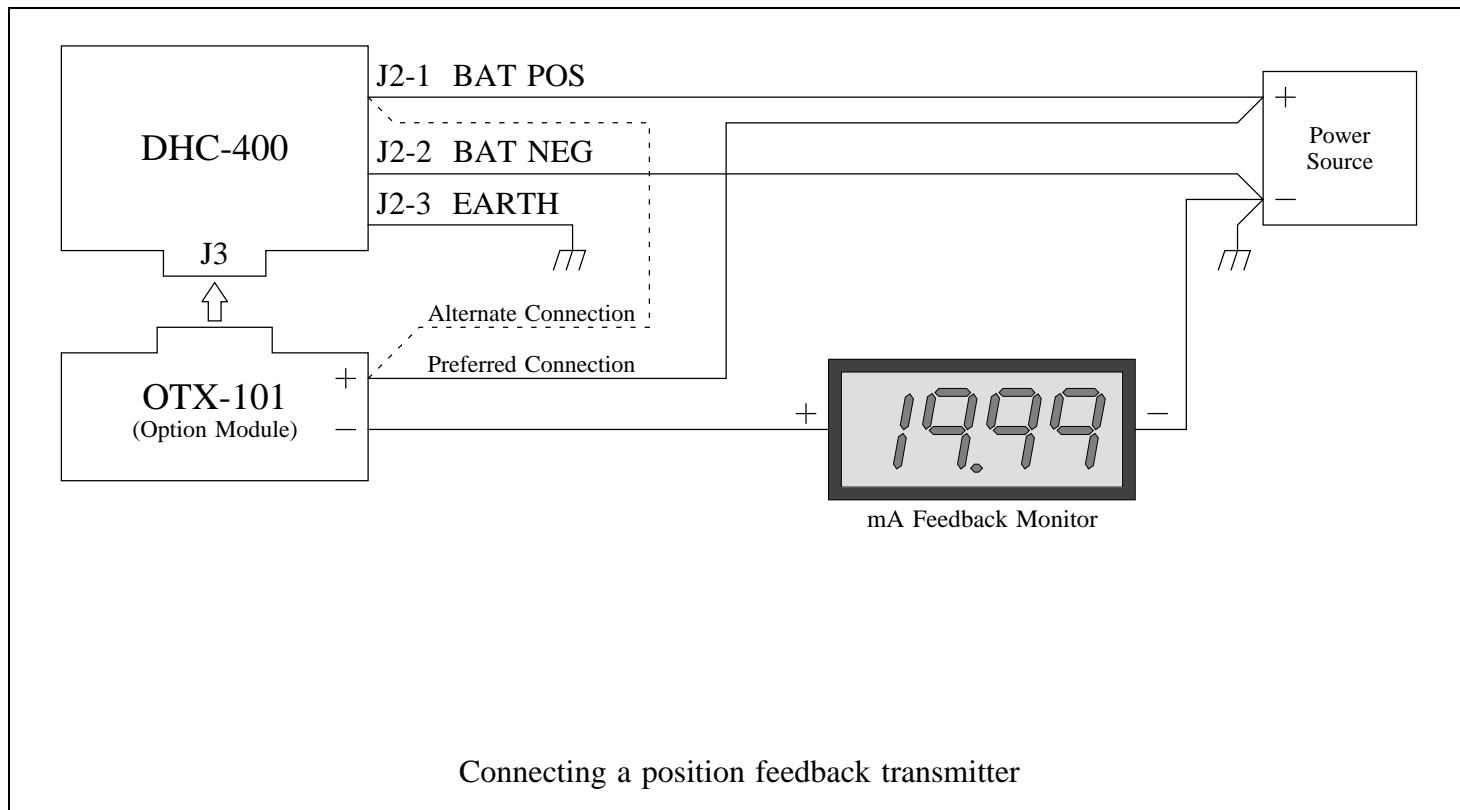

WIRE TABLE

The table below shows the maximum recommended distance (in linear feet) between the power source and the DHC-400 unit. The maximum distance is limited by the wire size used and the locked rotor current of the motor. The surge limiting feature along with an appropriate motor current trip setting can reduce wire size and power source requirements to a minimum (see TRIP SETTING). The wire distance is calculated for a maximum voltage drop of 1VDC with 20% of the locked rotor current, and assumes that the full load running current is less than that. All signal wires on the DHC-400 should be connected with wire sizes ranging from 22 to 18 AWG.

ft	Wire Size						
	18 AWG	16 AWG	14 AWG	12 AWG	10 AWG (see Note 1)	8 AWG (see Note 1)	6 AWG (see Note 1)
1	333	529	842	1337	2119	3383	5376
2	167	264	421	668	1059	1692	2688
5	67	106	168	267	424	677	1075
10	33	53	84	138	212	338	538
15	22	35	56	89	141	226	358
20	17	26	42	67	106	169	269
30	11	18	28	45	71	113	179
40	8	13	21	33	53	85	134
50	7	11	17	27	42	68	108
60	6	9	14	22	35	56	90

NOTES

- 1) The DHC-400 terminal strip will not accept wire sizes larger than 12 AWG. Use a short run of 12 AWG from the DHC-400 to an auxiliary terminal block when larger wire is needed.
- 2) If the motor is located some distance from the DHC-400, add this length to the overall wire length; be sure to use an appropriate wire size to the motor.
- 3) When multiple actuators are powered by a common set of wires, use the sum of all the motor currents when determining wire size.