

Quick Calibration Procedure

General

The MODE button selects a particular function, or mode, and the indicator for the selected mode turns on solid. Pushing the MODE button saves any new setting of the current mode before switching to the next mode. The adjust up (▲) and adjust down (▼) buttons are used to make adjustments to current mode. For more details regarding calibration and features refer to the manual.

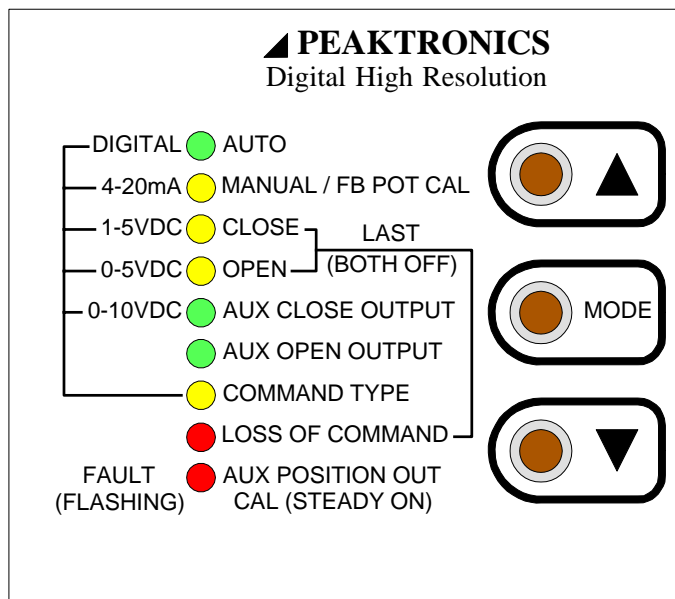

REFERENCE ROTATIONS

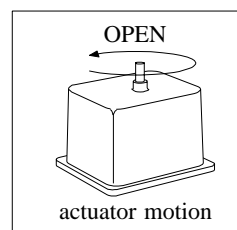

DIRECT ACTING

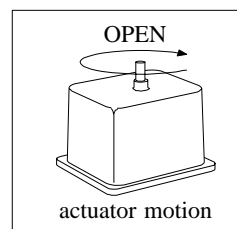

REVERSE ACTING

1. Before applying power, ensure that the unit is properly mounted and properly wired to the actuator. Refer to the pertinent MKT Data Sheet specified for the actuator. Ensure potentiometer gears are tight and properly meshed.
2. Apply power to the actuator on Connector J2: terminal #1 (neutral), terminal #2 (line), and terminal #3 (earth). There is no need for a signal connection during calibration.
3. Push the MODE button until the yellow “MANUAL/FB POT CAL” LED is illuminated. The LED may be flashing (at different speeds) through the next several steps. This is expected and will be explained.
4. Use the adjust buttons (▲ and ▼) to move the actuator and verify that the limit switches are set past the desired open and closed positions, but not so far as to interfere with the mechanical end stops, if the actuator has this feature. Then move the actuator to mid stroke.
5. If LED is solid, proceed to step 7.
6. If LED is flashing, loosen the gear on the actuator shaft and rotate the potentiometer gear until the LED is no longer flashing, but on solid - this indicates the center of the potentiometer’s travel. Note that the LED will flash at a slower rate the farther away from the mid position it gets. Once the LED is on solid tighten the actuator shaft gear and ensure that the gear engagement is tight and properly meshed.
7. Push the MODE button until the “CLOSE” LED is lit solid. Use the adjust buttons (▲ and ▼) to drive the actuator toward the desired closed position until the associated limit switch trips. Then tap the other adjust button to move the actuator just off the limit switch to the desired valve closed position.

Quick Cal & Troubleshooting Guide

8. Push the MODE button until the “OPEN” LED is lit solid. Use the adjust buttons (▲ and ▼) to drive the actuator toward the desired open position until the associated limit switch trips. Then tap the other adjust button to move the actuator just off the limit switch to the desired valve open position.
9. If an OTR-100 option module is installed, follow **Auxiliary Open/Close Setup** (see below); otherwise continue to the next step.
10. Push the MODE button until the “COMMAND TYPE” LED is lit solid. Use the adjust buttons (▲ and ▼) to select appropriate input signal (4-20mA, 1-5VDC, 0-5VDC, 0-10VDC, or Digital). If 0-5VDC or 0-10VDC is selected, the LOSS OF COMMAND feature is not available, so proceed to step 12.
11. Push the MODE button until the “LOSS OF COMMAND” LED is lit solid; this sets the actuator to a predetermined position upon loss of command. Use the adjust buttons (▲ and ▼) to select appropriate position (OPEN, CLOSE, or LAST POSITION).
12. If an OTR-100 or OTX-100 option module is installed, follow **Auxiliary Position Output Mode Setup** (see below); otherwise continue to the next step.
13. Push the MODE button until the “AUTO” LED is lit solid. Your calibration is now **COMPLETE**. Connect the command signal wires to connector J2: terminal #4 (signal ground) and terminal #5 (mA input) **OR** terminal #6 (voltage input), depending on the application. If a signal input was already connected, the actuator should have moved to that position.

Auxiliary Open/Close Setup (for units with an OTR-100 option module only)

1. Push the MODE button until the “AUX CLOSE OUTPUT” LED is lit solid. Use the adjust buttons (▲ and ▼) to drive the actuator to the desired auxiliary close position.
2. Push the MODE button until the “AUX OPEN OUTPUT” LED is lit solid. Use the adjust buttons (▲ and ▼) to drive the actuator to the desired auxiliary open position.
3. Continue with Step 10 in the **Quick Calibration Procedure** (see above).

Auxiliary Position Output Mode Setup (for units with an OTR-100, OTX-100, or OTX-101 option module only)

1. Push the MODE button until the red “AUX POSITION OUT CAL” LED is lit solid **while** the “CLOSE” LED flashes. Note that the red LED flashes to indicate a “Fault” and turns on solid to indicate the "AUX POSITION OUT CAL" modes.
2. Use the adjust buttons (▲ and ▼) to set the desired output voltage or current (mA) on the option module output for the closed position.
3. Push the MODE button so the “AUX POSITION OUT CAL” LED remains solid **while** the “OPEN” LED flashes. Use the adjust buttons (▲ and ▼) to set the desired output voltage or current (mA) on the option module output for the open position.
4. Continue with Step 13 in the **Quick Calibration Procedure** (see above).

Quick Cal & Troubleshooting Guide

PROBLEM	POSSIBLE CAUSES	REMEDIES
No response from unit (All lights are off.)	No power	Check power source.
	Excessive voltage applied to unit.	Replace unit.
	Blown or missing fuse	Replace with appropriate fuse; see "Specifications" in manual.
No response from unit, and no response from the adjust (▲ and ▼) or Mode buttons. (MANUAL / FB POT CAL light is lit solid.)	Jumper wire on J7 terminal block is missing.	Install jumper wire on J7 terminal block.
	Auto/Manual station is improperly wired.	Check wiring on Auto/Manual station; see "Override Mode" in manual.
Actuator rotates valve backwards.	Actuator or valve is mounted incorrectly on coupling.	Remount actuator as necessary.
	Actuator needs to be reverse acting.	Refer to "Close" and "Open" modes in manual.
Actuator does not respond to input signal. (FAULT indicator constantly flashes.)	No input signal connected when using 4-20mA, 1-5VDC, or Digital inputs.	Connect input signal and refer to "Loss of Command" in manual.
	Input signal polarity reversed.	Reverse input wires.
	Input signal wired to wrong terminal.	Check input signal wiring; refer to "Power/Signal J2" in manual.
	Feedback potentiometer or motor/solenoids are improperly wired.	Check wiring; refer to "Actuator J1" in manual.
	Feedback potentiometer out of range.	Refer to "Manual/FB Pot Cal" in manual.
	Defective feedback potentiometer.	Replace feedback potentiometer.
	Defective motor brake (holds motor)	Repair or replace motor brake.
	Defective motor (not turning)	Repair or replace motor.
Motor turns, but actuator output shaft is not moving.	Repair or replace actuator.	
Actuator does not respond to input signal. (FAULT indicator is off.)	Closed and open positions are set to the same position.	Set closed and open settings; refer to "Close" and "Open" modes in manual.
FAULT indicator flashes after actuator reaches the fully closed or open position.	Closed or open limit switches set inside the operating range.	Adjust limit switch cams; refer to "Close" and "Open" modes in manual.
	Torque switches trip due to mechanical end stops set inside the operating range.	Adjust mechanical end stops; refer to "Close" and "Open" modes in manual.

Quick Cal & Troubleshooting Guide

PROBLEM	POSSIBLE CAUSES	REMEDIES
AUX CLOSE OUTPUT or AUX OPEN OUTPUT indicators flash.	Actuator position is near closed or open.	<p>If an OTR-100 option module is installed, set Aux Close and Aux Open positions; refer to "Aux Close Output" and "Aux Open Output" modes in manual.</p> <p>If an OTR-100 option module is not installed, no remedy is required.</p>
Actuator operates erratically. (FAULT indicator flashes erratically.)	<p>AC ripple induced on the command input signal.</p> <p>Defective feedback potentiometer</p> <p>Loose feedback potentiometer or loose feedback potentiometer gears</p>	<p>Use equipment that isolates AC ripple from the command signal.</p> <p>Replace feedback potentiometer.</p> <p>Tighten feedback potentiometer and/or potentiometer gears.</p>
Actuator hunts for position.	<p>Sloppy gear tooth engagement</p> <p>No motor brake or brake slipping</p> <p>Unstable command input signal from PID control loop</p>	<p>Adjust feedback potentiometer gears for tight engagement.</p> <p>Install or repair motor brake.</p> <p>Adjust PID parameters for stable command signal.</p>
Triac output failure (Motor buzzes and overheats.)	<p>Exposure to water from conduit entrance</p> <p>Exposure to water from unsealed actuator housing</p> <p>Exposure to moisture from condensate</p> <p>Corrosion from exposure to salts or acids</p> <p>External power applied to motor connections at J1-1 or J1-3.</p> <p>Motor capacitor is defective, or has incorrect voltage rating.</p> <p>Lightning or power surge.</p>	<p>Perform appropriate remedy, <u>then</u> replace unit:</p> <p>Install drip loop at conduit entrance.</p> <p>Inspect and/or replace actuator housing gasket; use actuator with proper sealing.</p> <p>Use heater and thermostat and/or desiccant packets.</p> <p>Use corrosion inhibitors and desiccant packets.</p> <p>Remove connector J1 prior to applying external power.</p> <p>Replace motor capacitor.</p> <p>Replace unit.</p>