



STANDARDS

- Design Standard: API 609
- Flange Dimension: ASME B16.5 (24" and below), ASME B16.47 (26" and above) / DIN 2543, DIN 2544
- Face to Face Dimension: API 609, ASME B16.10 / EN558-1:1995 S13, S14, S16, S20, DIN 3202
- Test and Inspect: API 598 / DIN 3230

J Flow Controls Model 88 & 89 Series Butterfly Valves

FEATURES & BENEFITS

- Zero leakage, metal seated valve that features a triple eccentric, non-rubbing conical metal seat
- Tight shut off for thousands of cycles
- Bi-directional tight shutoff on services ranging from cryogenic to 1112°F (limitations governed by selection body, disc and seat material)
- Inherently fire safe
- 90° operation offers wide range of pneumatic, electric, and manual gear actuators

APPLICATIONS

- Cryogenic
- Pulp & Paper
- Petrochemical Plants
- Petroleum Refining
- Fossil Power Plants
- Nuclear Power Plants

FEATURES & BENEFITS

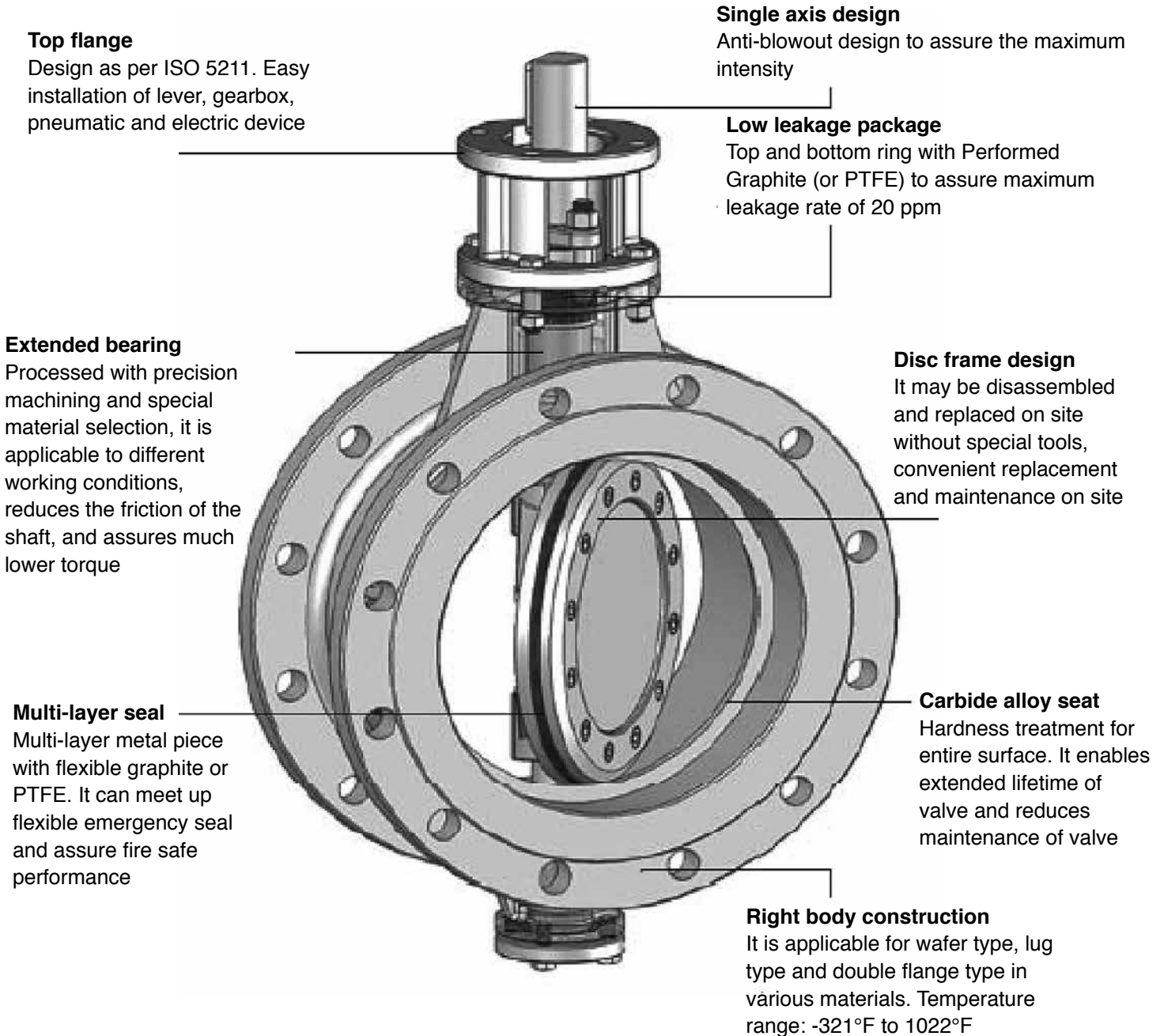

APPLICATIONS

CRYOGENICS

All Liquid Gases
Liquid and Natural Gas Service
Oil Field Recovery System
Gasification Plants and Storage
LNG Ship's Service

PULP AND PAPER

Steam Isolation, Boiler Water
Green, Red and Black Liquors
Oxygen Lines
Lime and Slurries

PETROCHEMICAL PLANTS

Brine, Co2 Vapor
Propylene Plants
Steam Service
Oxygen Service
Hydrogen Gas, Propane Gas
Flare Inlet and Manifold Isolation
Ethylene Plants

PETROLEUM REFINING

Oil Storage Isolation
Steam Supply Valves
Desulphurization Systems and Tail Gas Treaters
Flare Gas Hydrogen, Sour Gas Isolation
Hot Cracking Gas
Catalytic Cracker Units

FOSSIL POWER PLANTS

Pump Isolation
Condenser Cooling Pump and Steam Extraction Isolation
Heat Exchanger, Condenser Cooling Isolation

NUCLEAR POWER PLANTS

Containment Isolation
Saltwater Service
Core Spray Systems
Pump Isolation

TEST PRESSURE

Nominal Diameter	DN	2" - 36"	2" - 36"
Nominal Pressure	PN (MPa)	150 Lb	300 Lb
Test Pressure (MPa)	Shell Test	3	7.5
	Seal Test	2.2	5.5
Appropriate Medium	Water, Steam, Oil, Seawater		
Appropriate Temperature	-20°F - 797°F		

TRIPLE OFFSET DESIGN

The 88 and 89 Series Butterfly Valve provides a bi-directional bubble-tight shut off. This geometry ensures that the disc seal contacts the body seat only at the final shut off position without rubbing or galling, providing a torque generated resilient seal with sufficient "wedging" to ensure a uniform seal contact.

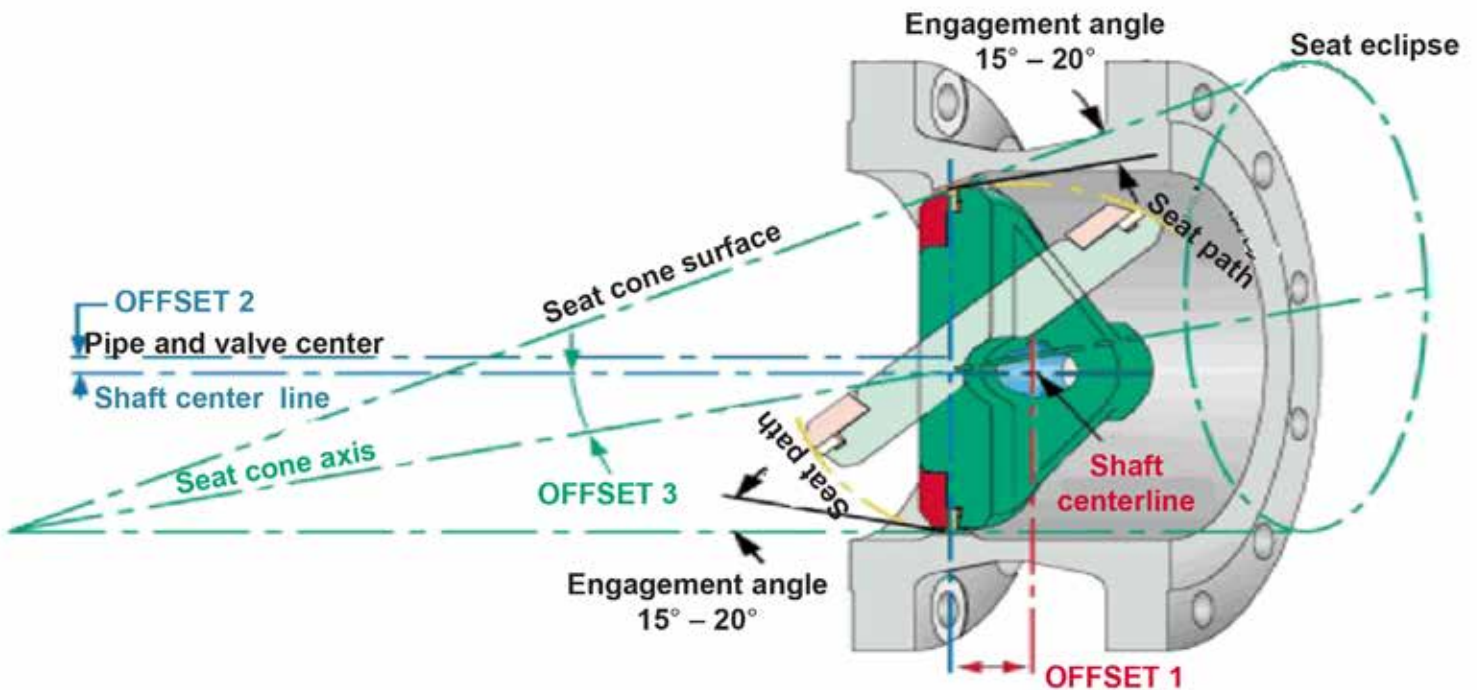

OFFSET 1	The shaft is offset behind the seat axis to allow complete sealing contact around the entire seat
OFFSET 2	The shaft center line is offset from the pipe and valve which provides interference free opening and closing of the valve
OFFSET 3	The seat cone axis is offset from the shaft center line to eliminate friction during closing and opening and to achieve uniform compressive sealing around the entire seat

Seating

Forces are generated by the torque during closing uniformly around the entire circumference. The resilient seal flexes and energizes, assuming the shape of the seat. The compression forces equally distributed around the perimeter provide a tight bi-directional shut off. The resiliency of the seal allows the valve body and disc to contract or expand, without the risk of jamming due to temperature fluctuations. It is self-adjusting.

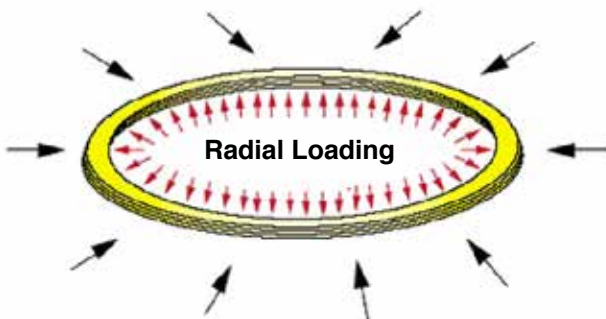

LAMELLAR SEAL DESIGN

The valve seal is manufactured from laminated stainless steel with graphoil laminate. The seal is held in position by a bolt-on retaining ring and, together with the stainless steel ring, is easily replaceable. A gasket prevents leakage around the seal ring. The metal seating valve can operate within a temperature range of -400°F to 1112°F. Valve designs for cryogenic applications are available upon request. The 88 & 89 Series Triple Eccentric Butterfly Valves are manufactured to suit most applications.

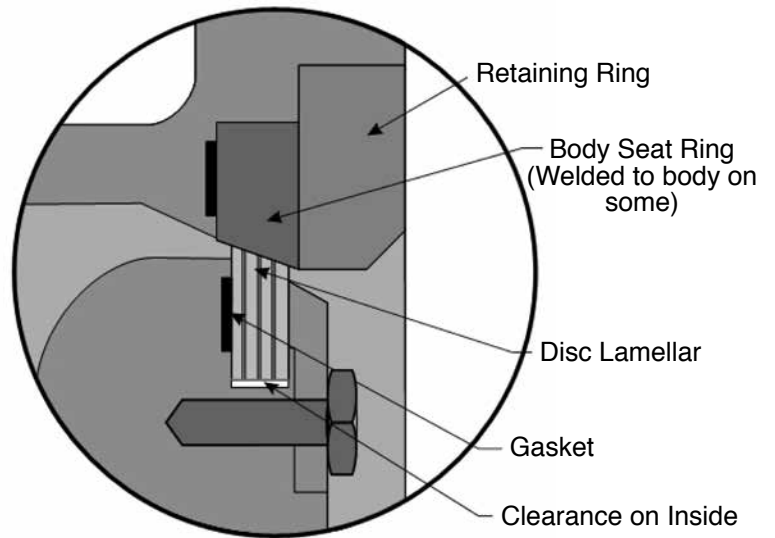

FEATURES & BENEFITS

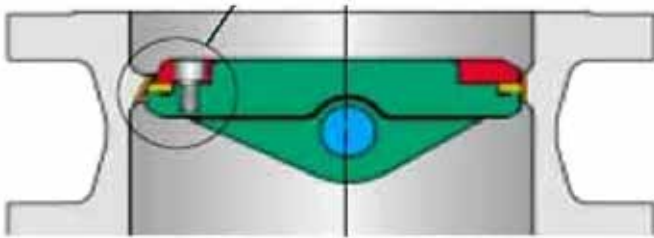

Raised, conical seat prevents solid buildup from interfering with seal. Seat is hard faced with Stellite to meet severe service. Alternative alloys are also used.

Zero Leakage Seat Tightness

The disc seal, evenly compressed around its circumference, produces a wedging effect which flexes the seal ring and reacts like a spring. The resilient seal assures "zero leakage" of liquids or gases to API 598 - resilient seat is standard. Resiliency in the seal allows disc movement during thermal cycles while retaining tight shutoff.

Laminated Resilient Disc Seal

Up to 500°F. One to four graphite layers are carefully assembled between stainless steel rings using Phenolic Resin. Flexible seal rings without glue are available for higher temperatures.

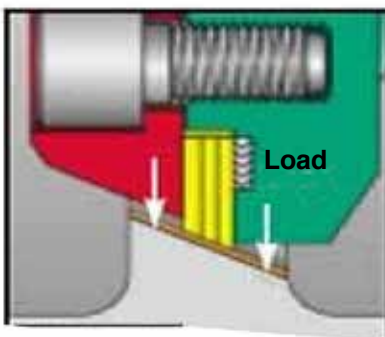

Internal

External

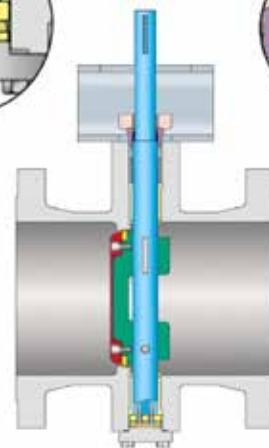

Double Shaft
Blowout Protection

STRUCTURE OF TRIPLE OFF-SEAT METAL SEAL BUTTERFLY VALVE

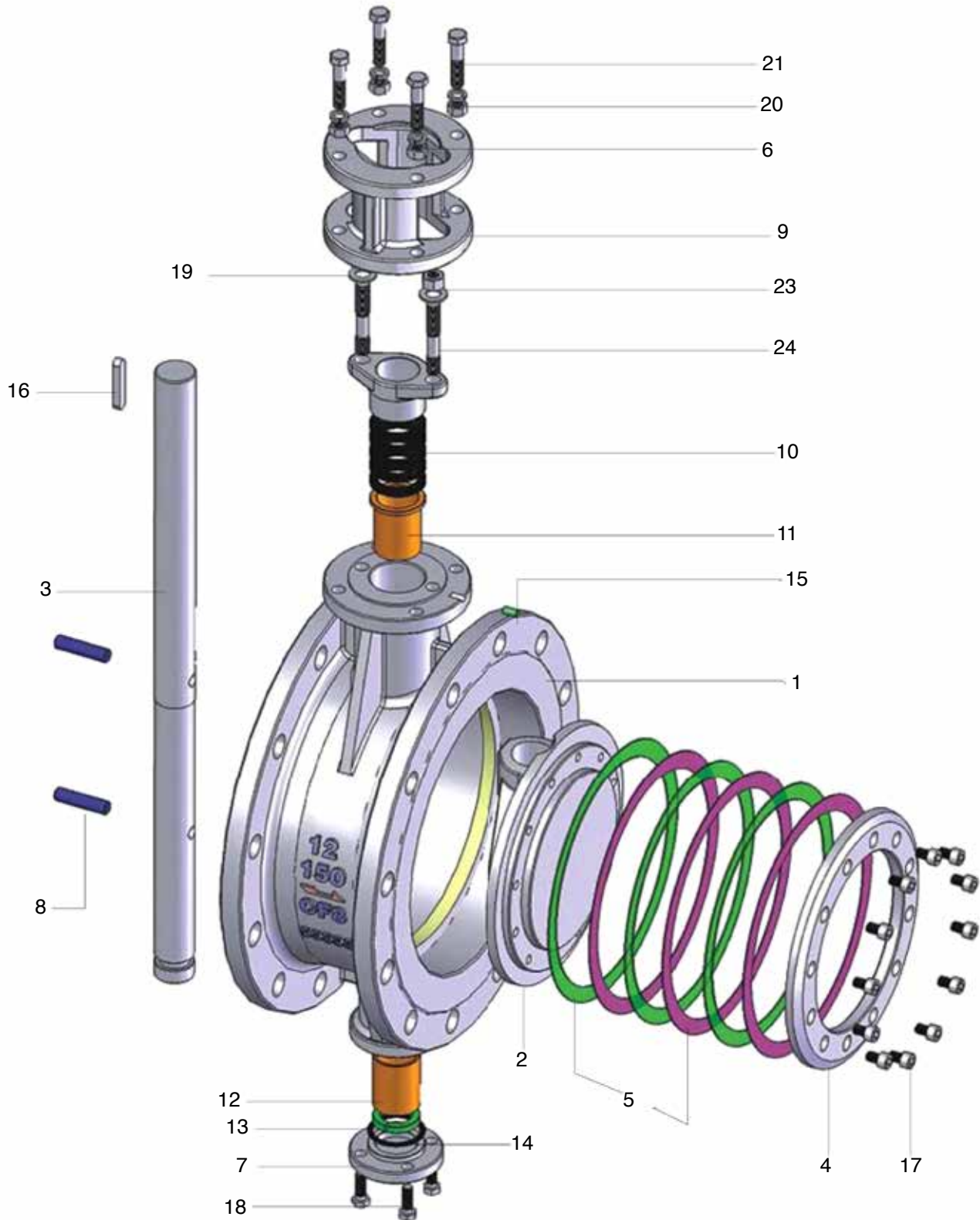

Model 88 & 89 Series Butterfly Valves

STANDARD MATERIAL OF TRIPLE OFF-SET METAL SEAL BUTTERFLY VALVE

No	Description	Temperature -20° - 797°F		Temperature -321° - 1000°F	
		CS	CF8	CF8M	
1	Body	A216 WCB	A351 CF8M	CF8M	
2	Disc	A216 WCB	A351 CF8M	CF8M	
3	Shaft	A182 F6A	A182 F304	A182 F316	
4	Retainer	A105 CS+ENP	SS 304	SS 316	
5	Seal Ring	SS316 + Flex Graphite	SS316 + Flex Graphite		
6	Yoke	A216 WCB	A216 WCB + ENP		
7	Bottom Cover	A105 CS	SS 304	SS 316	
8	Hinge Pin	A276 410	SS 304	SS 316	
9	Packing Gland	A216 WCB	A351 CF8	A351 CF8M	
10	Packing	Flex Graphite	Flex Graphite		
11	Front Axial Bushing	B148 C95500	B148 C95500		
12	Rear Axial Bushing	B148 C95500			
13	Split Ring	SS 304	SS 316		
14	Seal Gasket	SS304 + Flex Graphite	SS 304 + Flex Graphite		
15	Loose-Proof Pin	A276 410	SS 304		
16	Key	AISI 1045	AISI 1045		
17	Screw	A193 B8	A193 B8	A193 B8M	
18	Bolt	A193 B7	A193	A193 B8M	
19	Spring Gasket	AISI 1566	AISI 1566		
20	Nut	A194 2H	A194 8	A194 8M	
21	Bolt	A193 B7	A193 B8	A193 B8M	
22	Gasket	A105 CS	SS304	SS316	
23	Nut	A194 2H	A194 8	A94 8M	
24	Stud	A193 B7	A193 B8	A193 B8M	

Notes:

1. The above is the general specification. If there are special requirements by customers, J Flow Control will do a proper material selection according to the working condition.
2. For the valves used for special working conditions, please contact factory for materials and other specifications

Model 88 & 89 Series Butterfly Valves

API STANDARD DIMENSIONS

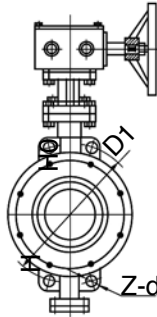

WAFER TYPE

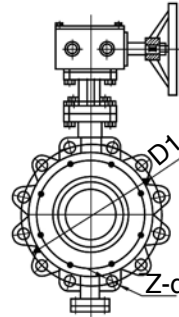

LUG TYPE

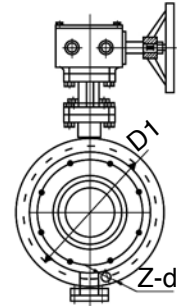

FLANGE TYPE

150 Lb Wafer and Double Flange Type

Size	Face to Face		External Dimensions		Connection (standard)					Weight (Lbs)	
	L (Wafer)	L1 (Flanged)	H	H0	D	D1	D2	M	Z-d		
2"	1.69	4.25	4.33	13.58	6.00	4.75	3.62	M18	4-19	20	44
3"	1.88	4.50	4.92	14.96	8.50	6.00	5.00	M18	4-19	24	64
4"	2.12	5.00	5.70	16.34	9.00	7.50	6.19	M18	8-19	29	73
5"	2.19	5.50	6.50	17.91	10.00	8.50	7.32	M20	8-22	35	84
6"	2.25	5.50	6.89	21.45	11.00	9.50	8.50	M20	8-22	57	163
8"	2.50	5.90	8.26	24.21	13.50	11.75	10.62	M20	8-22	75	190
10"	2.81	6.30	9.84	27.36	16.00	14.25	12.75	M24	12-25	112	313
12"	3.19	7.00	11.24	32.78	19.00	17.00	15.00	M24	12-25	159	368
14"	3.62	7.50	12.60	35.43	21.00	18.75	16.25	M27	12-29	234	481
16"	4.00	8.50	13.98	38.58	23.50	21.25	18.50	M27	16-29	293	606
18"	4.50	8.74	14.96	40.55	25.00	22.75	21.00	M30	16-32	388	695
20"	5.00	9.00	16.34	43.70	27.50	25.00	23.00	M30	20-32	419	871
24"	6.06	10.50	18.70	51.39	32.00	29.50	27.25	M33	20-35	869	1279
30"	6.50	11.50	22.38	60.03	38.75	36.00	33.75	M33	28-35	1049	1581
32"	7.50	12.50	24.80	62.40	41.75	38.50	36.00	M39	28-41	1362	1962
36"	7.88	13.00	26.77	69.48	46.00	42.75	40.25	M39	32-41	1680	2297

150 Lb Lug Type

Size	Face to Face	External Dimensions		Connection (standard)				Weight (Lbs)
	L (Lug)	H	H0	D1	D2	M	Z-d	
6"	2.25	6.89	21.45	9.50	8.50	M20	8-22	62
8"	2.50	8.26	24.21	11.75	10.62	M20	8-22	79
10"	2.81	9.84	27.36	14.25	12.75	M24	12-25	117
12"	3.19	11.24	32.78	17.00	15.00	M24	12-25	163
14"	3.62	12.60	35.43	18.75	16.25	M27	12-29	243
16"	4.00	13.98	38.58	21.25	18.50	M27	16-29	304
18"	4.50	14.96	40.55	22.75	21.00	M30	16-32	397
20"	5.00	16.34	43.70	25.00	23.00	M30	20-32	432
24"	6.06	18.70	51.39	29.50	27.25	M33	20-35	882
30"	6.50	22.38	60.03	36.00	33.75	M33	28-35	1063
36"	7.88	26.77	69.48	42.75	40.25	M39	32-41	1076

Model 88 & 89 Series Butterfly Valves

API STANDARD DIMENSIONS

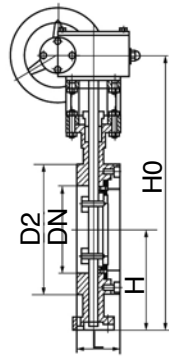

WAFER TYPE

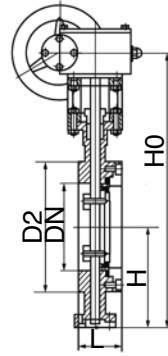

LUG TYPE

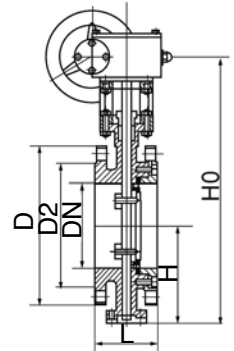

FLANGE TYPE

300 Lb Wafer and Double Flange Type

Size	Face to Face		External Dimensions		Connection (standard)					Weight (Lbs)	
	L (Wafer)	L1 (Flanged)	H	H0	D	D1	D2	M	Z-d		
2"	1.69	4.25	4.33	13.58	6.00	5.00	3.62	M18	8-19	20	44
3"	1.88	4.50	4.92	14.96	8.26	6.63	5.00	M20	8-22	27	64
4"	2.12	5.00	5.70	16.34	10.00	7.87	6.19	M20	8-22	29	77
5"	2.19	5.50	6.50	17.91	11.00	9.25	7.32	M20	8-22	40	88
6"	2.31	5.50	6.89	21.45	12.50	10.63	8.50	M20	12-22	62	179
8"	2.88	5.90	8.26	24.21	15.00	13.00	10.62	M24	12-26	82	207
10"	3.25	6.30	9.84	27.36	17.50	15.24	12.75	M27	16-29	124	348
12"	3.62	7.00	11.24	32.78	20.50	17.76	15.00	M30	16-32	174	404
14"	4.62	7.50	12.60	35.43	23.00	20.24	16.25	M30	20-32	256	527
16"	5.25	8.50	13.98	38.58	25.50	12.50	18.50	M33	20-35	322	666
18"	5.88	8.74	14.96	40.55	28.00	24.72	21.00	M33	24-35	426	763
20"	6.25	9.00	16.34	43.70	30.50	27.00	23.00	M33	24-35	461	957
24"	7.12	10.50	18.70	51.39	36.00	32.00	27.25	M39	24-41	955	1407
30"	6.50	11.50	22.38	60.03	43.00	39.25	33.75	M45	28-49	1153	1737
36"	8.00	13.00	26.77	69.48	50.00	46.00	40.25	M50	32-53	1848	2527

300 Lb Lug Type

Size	Face to Face	External Dimensions		Connection (standard)				Weight (Lbs)
	L (Lug)	H	H0	D1	D2	M	Z-d	
6"	2.31	6.89	21.45	10.63	8.50	M20	12-24	64
8"	2.88	8.26	24.21	13.00	10.62	M20	12-26	84
10"	3.25	9.84	27.36	15.24	12.75	M27	16-29	128
12"	3.62	11.24	32.78	17.76	15.00	M30	16-32	179
14"	4.62	12.60	35.43	20.24	16.25	M30	20-32	262
16"	5.25	13.98	38.58	22.3	18.50	M33	24-35	329
18"	5.88	14.96	40.55	24.72	21.00	M33	24-35	437
20"	6.25	16.34	43.70	27.00	23.00	M33	24-35	474
24"	7.12	18.70	51.39	32.00	27.25	M39	24-41	961
30"	9.01	22.38	60.03	39.25	33.75	M45	28-49	1164
36"	9.88	26.77	69.48	46.00	40.25	M50	32-53	1859

Model 88 & 89 Series Butterfly Valves

DIN STANDARD DIMENSIONS

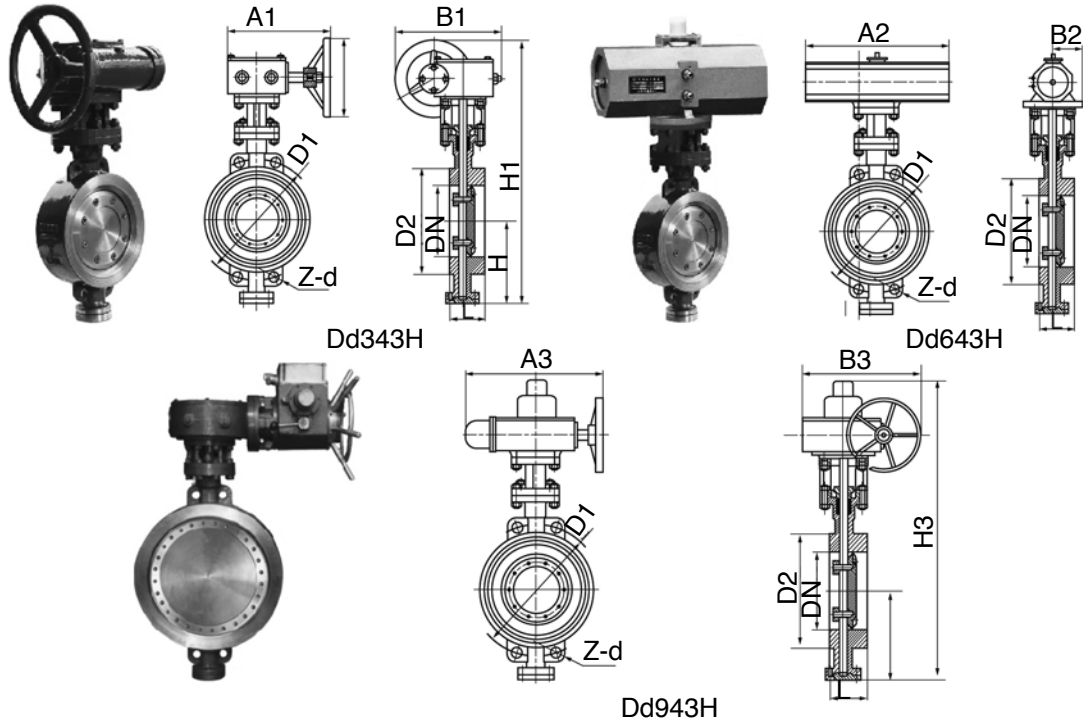

Wafer Type 1. 6MPa and 2. 5Mpa

Size	Face to Face	External Dimensions									Connection End						Wt Lbs
		L	H	Dd343H			Dd643H			Dd943H			PN1.6 Mpa		Pn2.5 Mpa		
				H1	A1	B1	H2	A2	B2	H3	A3	B3	D1	Z-d	D	D1	
2"	1.69	4.41	13.78	7.09	7.87	24.6	9.65	2.83	20.9	9.84	10.04	4.92	0.16-0.71	6.50	4.92	0.16-0.71	42
2-1/2"	1.81	4.53	14.57	7.09	7.87	24.6	9.65	2.83	20.9	9.84	10.04	5.71	0.16-0.71	7.28	5.71	0.31-0.71	49
3"	2.52	4.72	14.96	7.09	7.87	25.4	9.65	2.83	22.2	9.84	10.04	6.30	0.31-0.71	7.87	6.30	0.31-0.71	55
4"	2.52	5.43	16.54	7.09	7.87	26.6	14.0	3.62	23.6	9.84	10.04	7.09	0.31-0.71	9.25	7.48	0.31-0.87	62
5"	2.76	6.46	18.11	7.09	7.87	28.2	14.0	3.62	25.2	9.84	10.04	8.27	0.31-0.71	10.63	8.66	0.31-1.02	95
6"	2.99	6.89	21.9	10.63	11.02	31.5	14.0	6.69	27.8	11.81	12.40	9.45	0.31-0.87	11.81	9.84	0.31-1.02	110
8"	3.50	8.46	29.9	15.75	16.7	33.5	9.84	6.69	30.5	11.81	12.40	11.61	0.47-0.87	14.17	12.20	0.47-1.02	141
10"	4.49	9.57	32.7	15.75	16.7	36.4	9.84	8.66	37.2	11.81	12.40	13.98	0.47-1.02	16.73	14.57	0.47-1.18	218
12"	4.49	11.22	35.2	17.72	22.1	40.8	17.72	8.66	42.1	11.81	12.40	16.14	0.47-1.02	19.09	16.93	0.63-1.18	287
14"	5.00	12.60	37.4	17.72	22.1	42.1	17.72	8.66	44.9	11.81	12.40	18.5	0.63-1.18	21.9	19.29	0.63-1.30	415
16"	5.51	13.78	46.9	21.1	22.8	46.9	17.72	11.02	47.6	11.81	12.40	20.7	0.63-1.18	24.4	21.7	0.63-1.42	595
18"	5.98	13.78	49.4	21.1	22.8	49.2	25.6	11.02	52.6	22.6	28.1	23.0	0.79-1.18	26.4	23.6	0.79-1.42	772
20"	5.98	14.96	51.4	21.1	22.8	50.8	25.6	16.96	55.7	22.6	28.1	25.6	0.79-1.30	28.7	26.0	0.79-1.42	827
24"	6.06	17.13	52.8	22.4	26.0	57.3	33.5	14.96	63.2	25.8	31.9	30.3	0.79-1.42	33.3	30.3	0.79-1.54	1235
28"	6.50	18.90	59.8	29.5	21.7	62.4	33.5	14.96	72.6	25.8	33.1	33.1	0.94-1.42	37.8	34.5	0.94-1.65	1345
32"	7.48	20.87	67.3	29.5	21.7	66.9	49.2	14.96	80.3	30.9	31.9	37.4	0.94-1.54	42.7	39.0	0.94-1.89	1940
36"	7.99	23.43	71.3	29.5	21.7	77.4	49.2	14.96	88.8	30.9	37.9	41.3	1.10-1.54	46.7	42.9	1.10-1.89	2425
40"	8.50	25.59	77.2	35.4	29.5	79.3	49.2	14.96	93.7	30.9	34.0	46.1	1.10-1.65	52.0	47.6	1.10-2.20	4187
48"	10.00	30.51	98.4	39.4	36.4	88.6	49.2	14.96	104	30.9	34.0	54.7	1.26-1.89	60.2	55.9	1.26-2.20	4740
56"	10.98	34.25	95.9	39.4	36.4	-	-	-	114	-	-	53.5	1.42-1.89	69.1	64.6	1.42-2.44	7055
64"	12.52	439.37	109	39.4	36.4	-	-	-	124	-	-	71.7	1.57-2.20	77.8	73.2	1.57-2.44	11023
72"	14.02	43.70	119	43.3	38.6	-	-	-	137	-	-	79.5	1.73-2.20	86.4	81.5	1.73-2.76	15212
80"	15.98	49.21	129	43.3	38.6	-	-	-	145	-	-	87.8	1.89-2.44	95.5	90.6	1.89-2.76	20062

Model 88 & 89 Series Butterfly Valves

DIN STANDARD DIMENSIONS

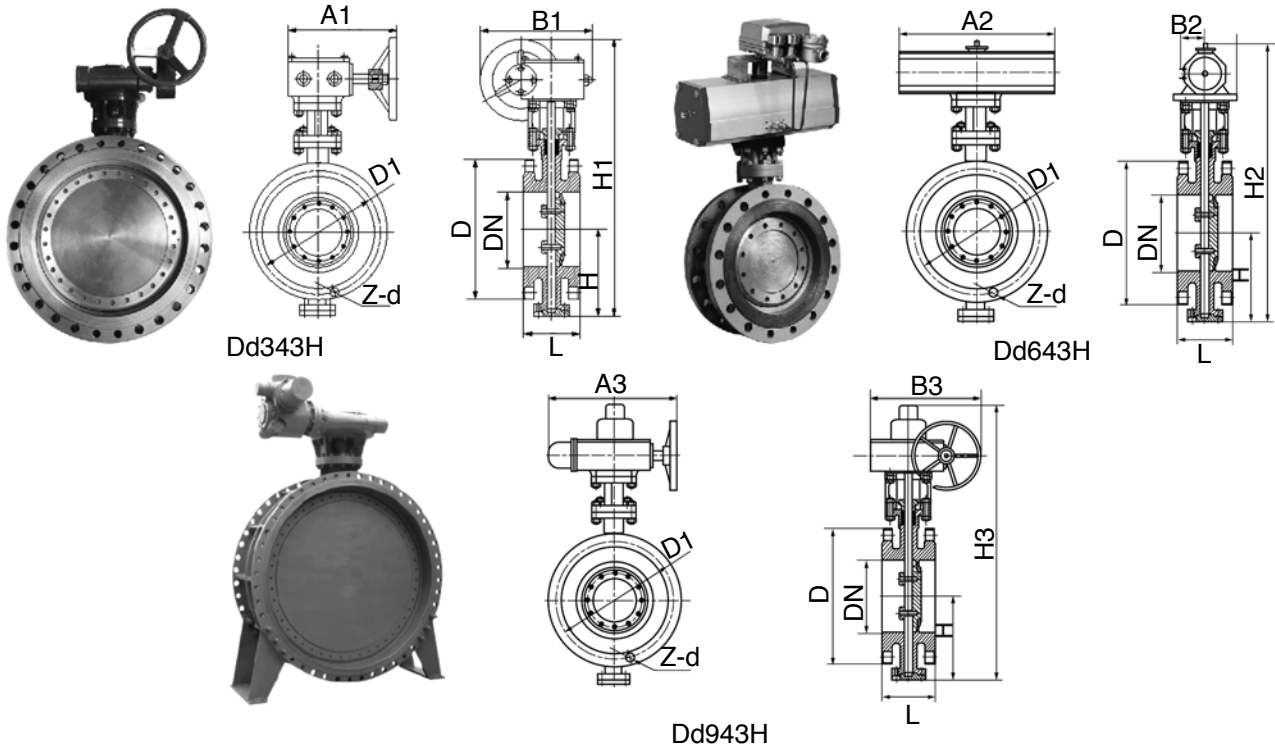

Double Flange Type 1. 6MPa and 2. 5Mpa

Size	Face to Face		External Dimensions										Connection End						Wt Lbs
	L		H	Dd373H			Dd673H			Dd973H			PN1.6 Mpa			Pn2.5 Mpa			
	Short	Long		H1	A1	B1	H2	A2	B2	H3	A3	B3	D	D1	Z-d	D	D1	Z-d	
2"	4.25	5.91	4.41	13.78	7.09	7.87	24.6	9.65	2.83	20.9	9.84	10.04	6.50	4.92	0.16-0.71	6.50	4.92	0.16-0.71	42
2-1/2"	4.41	6.69	4.53	14.57	7.09	7.87	24.6	9.65	2.83	20.9	9.84	10.04	7.28	5.71	0.16-0.71	7.28	5.71	0.31-0.71	49
3"	4.49	7.09	4.72	14.96	7.09	7.87	25.4	9.65	2.83	22.2	9.84	10.04	7.87	6.30	0.31-0.71	7.87	6.30	0.31-0.71	55
4"	5.00	7.48	5.43	16.54	7.09	7.87	26.6	14.0	3.62	23.6	9.84	10.04	8.66	7.09	0.31-0.71	9.25	7.48	0.31-0.87	62
5"	5.51	7.87	6.46	18.11	7.09	7.87	28.2	14.0	3.62	25.2	9.84	10.04	9.84	8.27	0.31-0.71	10.63	8.66	0.31-1.02	95
6"	5.98	8.27	6.89	21.9	10.63	11.02	31.5	14.0	6.69	27.8	11.81	12.40	11.22	9.45	0.31-0.87	11.81	9.84	0.31-1.02	110
8"	5.98	9.06	7.87	29.9	15.75	16.7	33.5	9.84	6.69	30.5	11.81	12.40	13.39	11.61	0.47-0.87	14.17	12.20	0.47-1.02	141
10"	6.50	9.84	9.57	32.7	15.75	16.7	36.4	9.84	8.66	37.2	11.81	12.40	15.94	13.98	0.47-1.02	16.73	14.57	0.47-1.18	218
12"	7.01	10.63	9.84	35.2	17.72	22.1	40.8	17.72	8.66	42.1	11.81	12.40	18.11	16.14	0.47-1.02	19.09	16.93	0.63-1.18	287
14"	7.48	11.42	11.02	37.4	17.72	22.1	42.1	17.72	8.66	44.9	11.81	12.40	20.5	18.5	0.63-1.18	21.9	19.29	0.63-1.30	415
16"	8.50	12.20	12.01	46.9	21.1	22.8	46.9	17.72	11.02	47.6	11.81	12.40	22.8	20.7	0.63-1.18	24.4	21.7	0.63-1.42	595
18"	8.74	12.99	13.78	49.4	21.1	22.8	49.2	25.6	11.02	52.6	22.6	28.1	25.2	23.0	0.79-1.18	26.4	23.6	0.79-1.42	772
20"	9.02	13.78	14.96	51.4	21.1	22.8	50.8	25.6	16.96	55.7	22.6	28.1	28.2	25.6	0.79-1.30	28.7	26.0	0.79-1.42	827
24"	10.1	15.35	17.52	52.8	22.4	26.0	57.3	33.5	14.96	63.2	25.8	31.9	33.1	30.3	0.79-1.42	33.3	30.3	0.79-1.54	1235
28"	7.56	16.93	18.90	59.8	29.5	21.7	62.4	33.5	14.96	72.6	25.8	33.1	35.8	34.5	0.94-1.42	37.8	34.5	0.94-1.65	1345
32"	12.52	18.50	20.9	67.3	29.5	21.7	66.9	49.2	14.96	80.3	30.9	31.9	40.4	39.0	0.94-1.54	42.7	39.0	0.94-1.89	1940
36"	12.99	20.08	22.8	71.3	29.5	21.7	77.4	49.2	14.96	88.8	30.9	37.9	44.3	42.9	1.10-1.54	46.7	42.9	1.10-1.89	2425
40"	16.14	21.65	25.6	77.2	35.4	29.5	79.3	49.2	14.96	93.7	30.9	34.0	49.4	47.6	1.10-1.65	52.0	47.6	1.10-2.20	4187
48"	6.69	24.80	29.9	98.4	39.4	36.4	88.6	49.2	14.96	104	30.9	34.0	58.5	55.9	1.26-1.89	60.2	55.9	1.26-2.20	4740
56"	20.87	27.95	33.5	95.9	39.4	36.4	-	-	-	114	-	-	66.3	64.6	1.42-1.89	69.1	64.6	1.42-2.44	7055
64"	23.62	31.10	40.6	109	39.4	36.4	-	-	-	124	-	-	76.0	73.2	1.57-2.20	77.8	73.2	1.57-2.44	11023
72"	26.38	34.25	48.4	119	43.3	38.6	-	-	-	137	-	-	83.9	81.5	1.73-2.20	86.4	81.5	1.73-2.76	15212
80"	29.92	37.40	53.2	129	43.3	38.6	-	-	-	145	-	-	92.3	90.6	1.89-2.44	95.5	90.6	1.89-2.76	20062

Model 88 & 89 Series Butterfly Valves

HOW TO ORDER

Model		Body Material, Disc & Stem		Packing		Seat		End Connection	
88	Wafer Style	88	A350LF2/LCB	G	Graphoil	M	Metal Seated	F	Flanged
89	Lug Style	22	WCB/A105	T	TFE	R	Reinforced	F1	ANSI 150
		33	316 CF8M			T	PTFE (Teflon)	F3	ASI 300
		44	Alloy 20			TC	Carbon TFM	RTJ	Ring Type Joint
						TM	Super-Teflon		

Options	
GO	Gear Operator
SE	Stem Extension

J Flow Controls®
 4665 Interstate Drive
 Cincinnati, OH 45246
 513-731-2900
jflowcontrols.com

While the information and specifications contained in this literature are believed to be accurate, they are supplied for informative purposes only and should not be considered certified or a guarantee of satisfactory results. Nothing contained herein is to be construed as a warranty or guarantee, express or implied, regarding any matter with respect to this product. Because J Flow Controls® is continually improving and upgrading its product design, the specifications, dimensions and information contained herein are subject to change without notice.