

# Electro Pneumatic Positioner



## 5700 Series

# Instruction Manual



# Table of Contents

<b>1</b>	<b>Introduction</b> -----	4
1.1	General information for the user-----	4
1.2	Requirement for safety-----	5
1.3	Basic safety instructions for use in the Ex area-----	6
1.4	Conditions to maintain intrinsic safety (Ex i)-----	6
<b>2</b>	<b>Description of Products</b> -----	7
2.1	Function-----	7
2.2	Features-----	7
2.3	Options-----	7
2.4	Applications-----	7
2.5	Name plats-----	8
2.6	Products number-----	9
2.7	Specifications-----	10
	2.7.1 Positioner-----	10
	2.7.2 Position transmitter(Option)-----	10
2.8	Operation logic-----	11
2.9	Parts and Assembly-----	12
	2.9.1 Standard type-----	12
	2.9.2 With Position transmitter type-----	13
2.10	Dimension drawings-----	14
	2.10.1 5700L Dimensions-----	14
	2.11.2 5700R Dimensions-----	15
<b>3</b>	<b>Installation</b> -----	16
3.1	Safety-----	16
3.2	5700L installation-----	16
3.3	5700R installation-----	18
	3.3.1 Fork lever type-----	18
	3.3.2 NAMUR Type-----	18

<b>4</b>	<b>Air connection</b> -----	19
4.1	Notice-----	19
4.2	5700L Piping connection to Actuator-----	19
4.3	5700L RA/DA action setting-----	19
4.4	5700R Piping connection to Actuator -----	20
4.5	5700R RA/DA action setting-----	20
<b>5</b>	<b>Power connections</b> -----	21
5.1	Explosion proof type power connection-----	21
5.2	Intrinsically safe type power connection-----	23
5.3	With Position transmitter type power connection-----	24
<b>6</b>	<b>Adjustment</b> -----	25
6.1	Zero Span Adjustment-----	25
6.2	Setting of the Position transmitter-----	26
<b>7</b>	<b>Troubleshooting</b> -----	27
7.1	Common problems-----	27
7.2	Install orifice-----	27
7.3	Position transmitter-----	28
7.4	Other problems and resolution-----	29
<b>8</b>	<b>Limited warranty and disclaimer</b> -----	30

# 1 Introduction

## 1.1 General information for the user

This instruction includes installation, operation, maintenance, and parts information for Tissin 5700 Valve Positioner. Keep these instructions in a location which is easily accessible to every user and make these instructions available to every new owner of the device. □

- 
- Installation, commissioning and maintenance of the product may only be performed by trained specialist personnel who have been authorized by the plant operator to do so.
  - To avoid possible injury to personnel or damage to valve parts, WARNING, CAUTION and NOTICE should be strictly followed.
  - Before installing or commissioning, be sure to read and thoroughly understand the product manual and operate the product properly.
  - Operators must strictly observe the applicable national regulations with regards to installation, function tests, repairs, and maintenance of electrical products.
  - For additional information or if specific problems occur that are not discussed in these instructions, contact the manufacturer.

---

The manual can be altered or revised without any prior notice.  
Please visit our website (<http://www.tissin.co.kr> ) check the latest documentation.

---

Manual version	PM-5700KR-7/2017
----------------	------------------

---

## 1.2 Requirement for safety

This manual contains notices you have to observe in order to ensure your personal safety, as well as to prevent damage to property. These safety instructions are intended to prevent hazardous situations and/or equipment damage. For the safety, it is important to follow the instructions in the manual.



**WARNING** Failure to observe the warning may result in serious injuries or death.



**CAUTION** Failure to observe this warning may result in product failure or injuries.



**NOTICE** Failure to observe this warning may result in product failure or performance degradation.

---

### Safety notes



### CAUTION

---

- Only trained and authorized person should operate machinery and equipment.
  - Do not use this positioner out of the range of its specifications as this can cause failure.
  - Do not service or attempt to remove product and machinery/equipment until safety is confirmed.
  - Before loosening the pneumatic lines and valves, turn off the pressure and vent the pneumatic lines.
  - Before reaching into the device or the equipment, switch off the power supply and secure to prevent reactivation.
  - Observe applicable accident prevention and safety regulations for electrical equipment.
-

### 1.3 Basic safety instructions for use in the Ex area

To prevent the risk of explosion, observe not only the basic safety instructions in the respective operating instructions for operation in the Ex area, but also the following.

---

 **WARNING**

---

- Observe the applicable safety regulations (also national safety regulations) as well as the general rules of technology for construction and operation.
  - Make sure that the device is suitable for the area of use.
  - Check the positioner's certified and permitted explosion proof range.
  - Close all unnecessary cable glands with lock screws approved for the explosions area.
  - 5700 series has 2 conduit entries. Flameproof cable must be used for cable entry, and for unused cable entry, flameproof blind cable plug should be used.
  - 5700 series is certified under flame proof (Ex dmb IIB T5/T6 or Ex dmb IIC T5/T6). Explosion proof zones 1 and 2.
- 

### 1.4 Conditions to maintain intrinsic safety (Ex i)

---

 **WARNING**

---

- Connect the device with type of protection "Intrinsic safety" solely to an intrinsically safe circuit.
  - Observe the specifications for the electrical data on the certificate and in technical data.
  - 5700 series is certified under intrinsically safe (Ex ia IIB T5/T6 or Ex ia IIC T5/T6). Explosion proof zones 0, 1 and 2.
- 

#### Intrinsic safety explosion standard

Explosion regulations	GB 3836.1-2010 GB3836.4-2010				
Explosion proof	Ex ia IIC T5/T6				
Barrier specifications	Ui	li	Pi	Ci	Li
Main power	30V	100mA	1W	1nF	35uH

## 2 Description of products

### 2.1 Function

Electro-Pneumatic valve positioner 5700 series controls the valve stroke in response to an input signal of 4~20mA DC from the control panel, DCS or calibrator.

### 2.2 Features

- Applied to various control valve system
- Fast response time, durability, and excellent stability
- Simple zero and span adjustment
- IP 66 enclosure
- Easy maintenance due to built-in module type
- Strong to vibrations and No resonance between 5 - 200 Hz
- By-pass valve (A/M switch) installed
- Air connection part is designed for detachability and it can be changed PT/NPT tapping threads in the field easily

### 2.3 Options

- Position transmitter(4~20mA DC Feedback signal)
- Limit switch (Mechanical or Proximity type)

### 2.4 Applications

The 5700 is mounted on a pneumatic control valves and is used for fluid control in industrial parts.

- Oil and gas
- Chemicals
- Power plant
- Paper
- Water treatment
- Pharmaceutical
- Printing and dyeing processing
- Food and beverage
- Other

## 2.5 Name plates

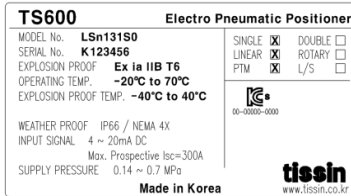

<Ex ia IIB T6 >

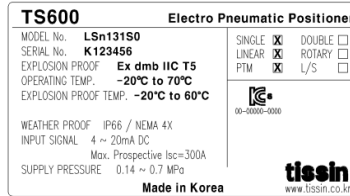

<Ex dmb IIC T6>

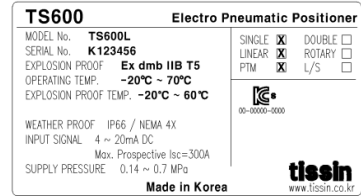

<Ex dmb IIB T6>

Item	Description
<b>MODEL No.</b>	Indicates model number.
<b>SERIAL No.</b>	Indicates serial number.
<b>EXPLOSION PROOF</b>	Indicates certified explosion proof grade.
<b>OPERATING TEMP.</b>	Indicates allowable operating temperature.
<b>AMBIENT TEMP.</b>	Indicates explosion proof temperature. This temperature range must be observed when using in explosion-proof areas.
<b>WEATHER PROOF</b>	Indicates enclosure grade.
<b>INPUT SIGNAL</b>	Indicates input signal range.
<b>SUPPLY PRESSURE</b>	Indicates supply pressure range.



## 2.6 Product number

Model	5700						
<b>Acting Type</b>	Linear Type	L					
	Rotary Type	R					
<b>Explosion proof type</b>	Non-Explosion type		N				
	Ex dmb IIB T5/T6		B				
	Ex dmb IIC T5/T6		C				
	Ex ia IIC T5/T6		A				
<b>Connection type</b>	<u>Conduit Entry</u>	<u>Air Connection</u>					
	G(PF)1/2	PT1/4		1			
	G(PF)1/2	NPT1/4		2			
	NPT1/2	NPT1/4		3			
<b>Linear lever type</b>	10~40mm				1		
	40~70mm				2		
	70~100mm				3		
	100~150mm				4		
<b>Rotary lever type</b>	M6 x 34L (Fork lever type)				1		
	NAMUR Type				5		
<b>Ambient Temp.</b>	-20~70℃ (Standard)					S	
	-20~120℃*					H	
	-40~70℃					L	
<b>Options*</b>	None						0
	With Position transmitter (4~20mA)*						1
	With Limit Switch *						2
	With Limit Switch (Explosion proof type)						3
	With Position transmitter and Limit Switch*						4
	With Position transmitter and Limit Switch (Explosion proof type)						5
With external Limit switch mounting device						6	

### Note

1. High temperature (-20~120℃) positioner must be Non-explosion proof type
2. Options no.1,2,4 must be Non-explosion proof type.

## 2.7 Specifications

### 2.7.1 Positioner

Model		5700L		5700R	
		Single	Double	Single	Double
Input signal		4~20mA DC			
Impedance		250±15Ω			
Supply pressure		0.14~0.7MPa			
Stroke		10~150mm		0~90°	
Air connection		PT(NPT) 1/4			
Gauge connection		PT(NPT) 1/8			
Conduit		G(PF) 1/2 or NPT 1/2			
Explosion proof		Non-explosion proof Ex dmb IIB T5/T6, Ex dmb IIC T5/T6 Ex ia IIC T5/T6			
Enclosure		IP66			
Ambient Temp.	Operating Temp.	-20℃ ~ 70℃ (Standard), -40℃ ~ 70℃ (Low Temp.), -20℃ ~ 120℃ (High Temp.)			
	Explosion proof Temp.	-40℃ ~ 60℃ (T5) / -40℃ ~ 40℃ (T6)			
Linearity		±1.0% F.S	±2.0% F.S	±1.0% F.S	±2.0% F.S
Sensitivity		±0.2% F.S	±0.5% F.S	±0.2% F.S	±0.5% F.S
Hysteresis		±1.0% F.S			
Repeatability		±0.5% F.S			
Air consumption		Below 2.5LPM (Sup=0.14MPa)			
Flow capacity		Over 80LPM (Sup=0.14MPa)			
Material		Aluminum die casting			
Weight		2.8kg			

### 2.7.2 Position transmitter (Option)

Item type	Specification
Input voltage	9~30V DC
Output current	4~20mA DC
Connection type	2 Wire Type
Impedance	Max.600Ω / 30V
Range of temperature	-40℃ ~ 85℃
Linearity	±1%
Sensitivity	±0.2%
Hysteresis	1%

## 2.8 Operation logic

The diaphragm valve moves downward. The movement of diaphragm valves acts on Feedback spring through Feedback lever and Flapper increases torque to the left pull. The diaphragm valve is balanced at the position between the above spring torque and magnetic field strength generated by the input current. Gain suppression spring is used to immediately feedback the movement of the Pilot Valve to the Flapper and it increases the loop\* stability.

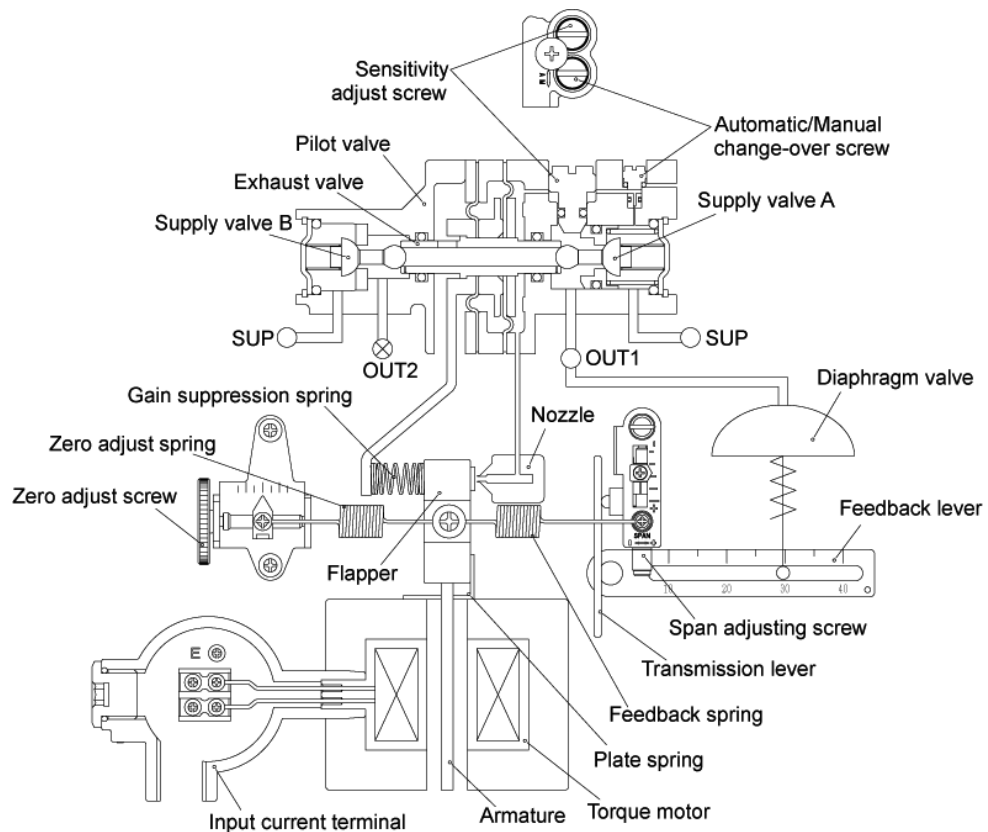

<Logic 5700L Operation >

- \* The diagrams above explanations based on 5700L linear type and Diaphragm valve of RA (Reverse Action) type. 5700R rotary type is same as Operation logic of 5700L linear type except feedback structure.
- \* Nozzle back pressure internal pressure of Nozzle depends on the control the Nozzle by the Flapper.
- \* Loop Positioner and Control valve consist of closed-circuit through Feedback lever.

## 2.9 Parts and Assembly

### 2.9.1 Standard type

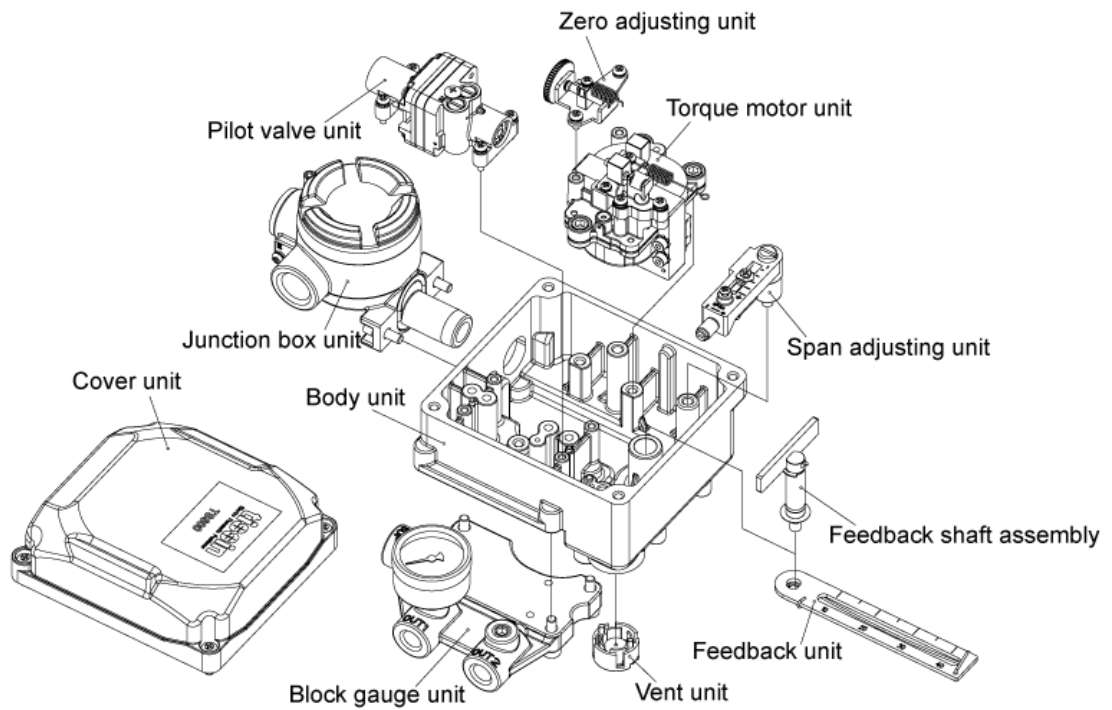

### 2.9.2 With Position transmitter type

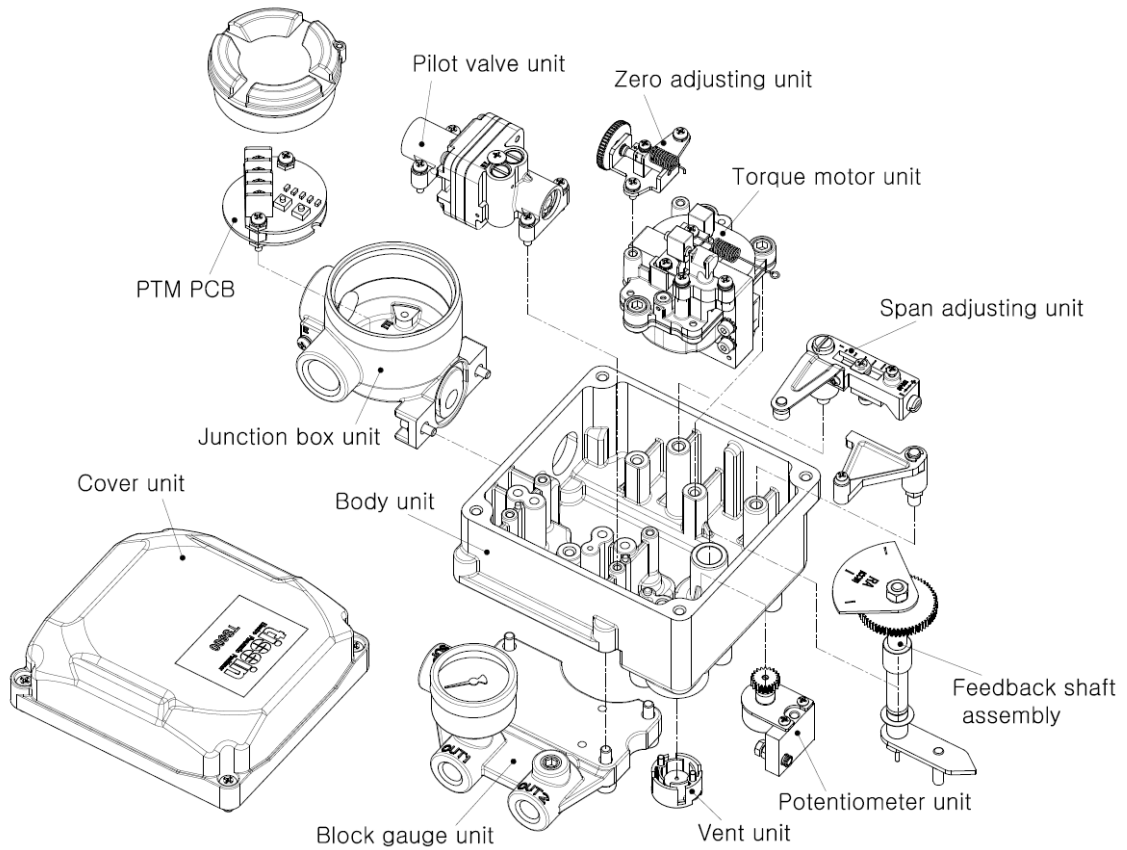

## 2.10 Dimension drawings

### 2.10.1 5700L Dimensions

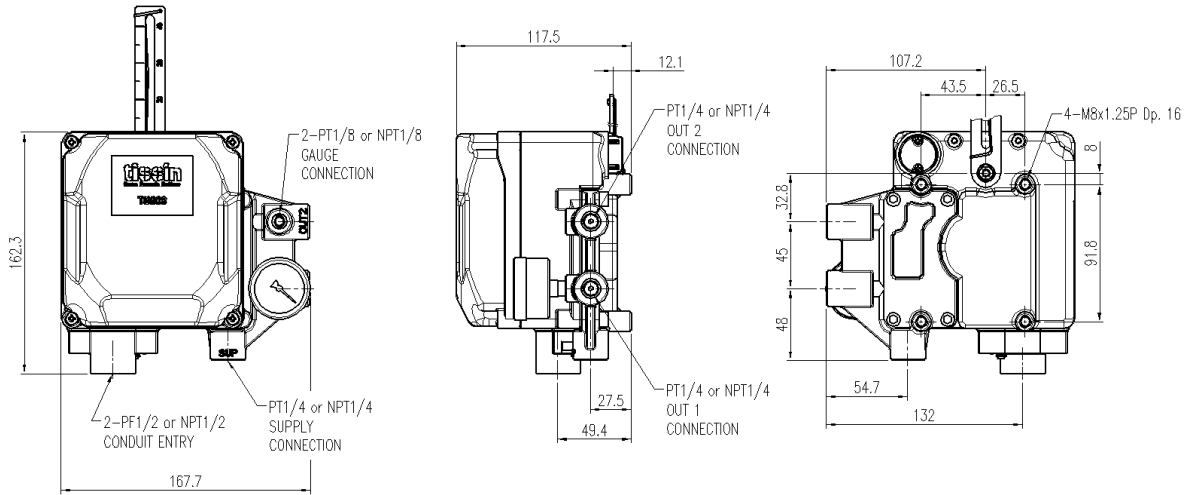

<5700L Intrinsically Safe Type & Non-Explosion Type Dimension>

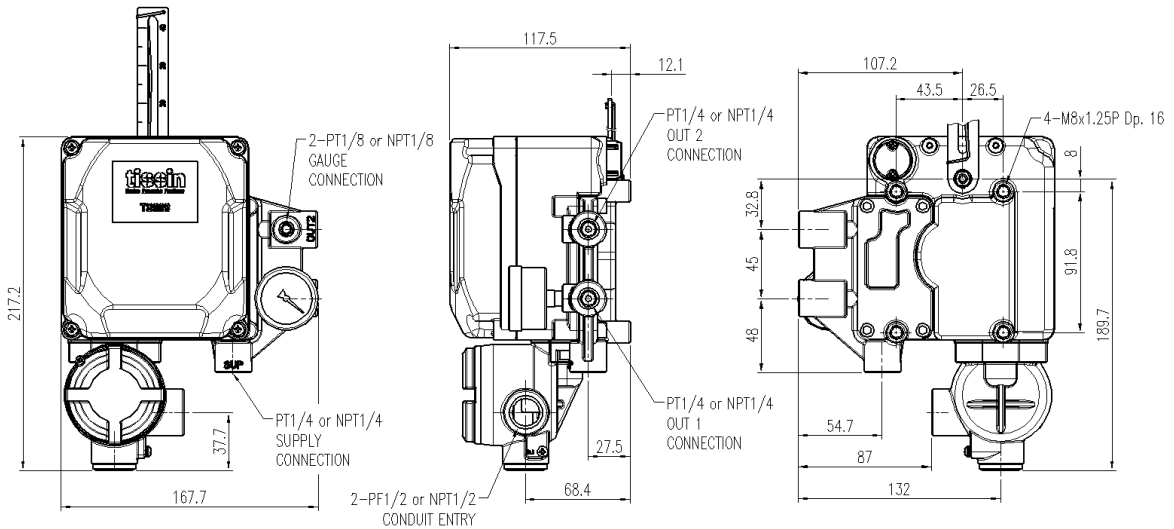

<5700L Explosion Proof Type Dimension >

#### Note

With Position transmitter type has the same dimensions as Explosion proof type.

2.10.2 5700R Dimensions

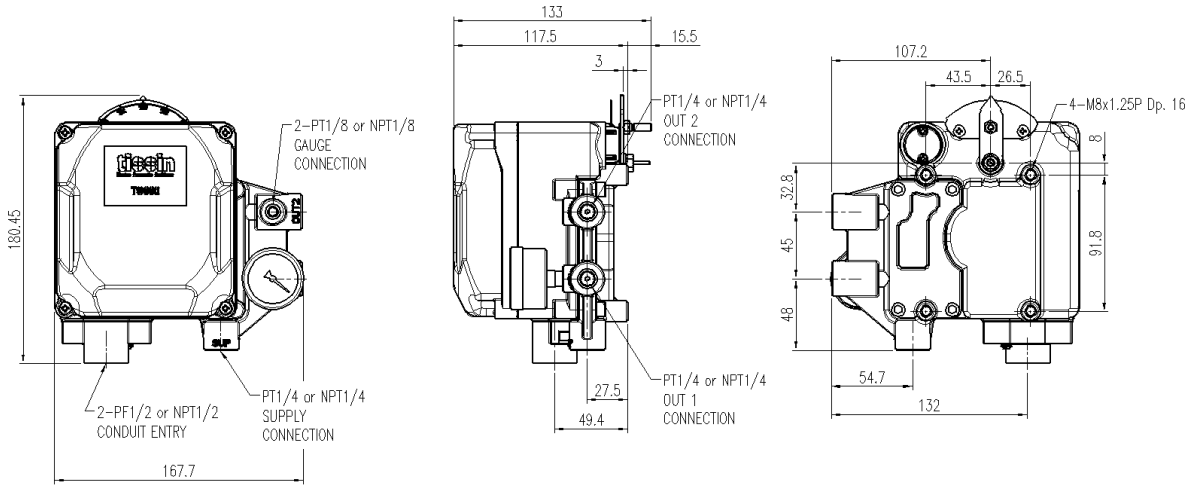

<5700R Intrinsically Safe Type & Non-Explosion Type Dimension>

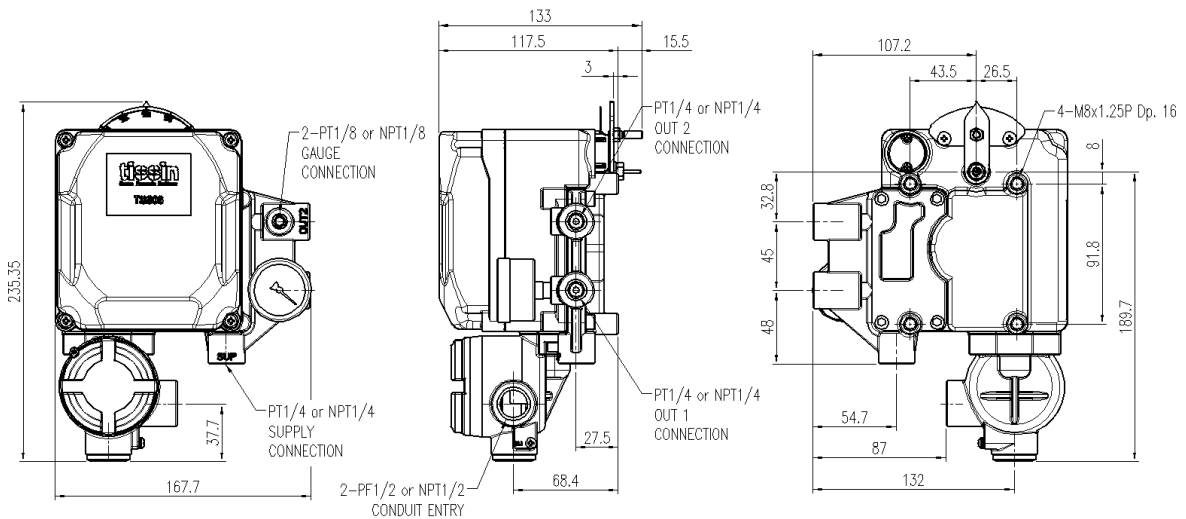

<5700LR Explosion Proof Type Dimension>

**Note**

With Position transmitter type has the same dimensions as Explosion proof type.

### 3 Installation

#### 3.1 Safety

---

**⚠ WARNING**

---

When installing a positioner, please ensure to read and follow safety instruction.

- Make a space needed for maintenance on the setting area.
  - Cut supply pressure and release compressed air in positioner and actuator in advance.
- 

#### 3.2 5700L Installation

---

**⚠ CAUTION**

---

Proper bracket must be made in order to adapt the positioner on the actuator yoke. Please consider following important points when a bracket is being designed.

- Check if feedback lever is parallel to the ground at 50% of the valve stroke. <Figure 1>
  - Feedback lever connection with the pin of the actuator clamp should be installed in such a way that the valve stroke and numbers which indicated on the feedback lever must be fitted. <Figure2>
- 

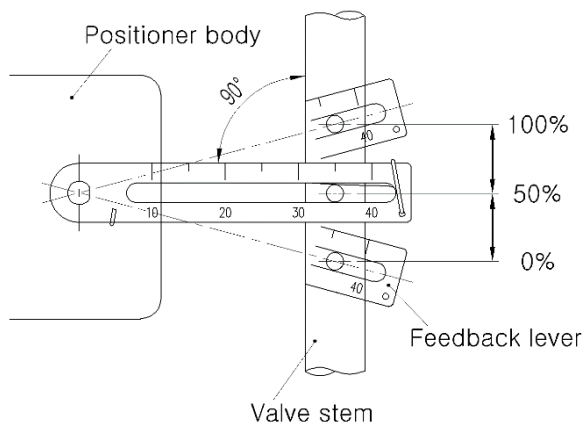

<Figure 1>

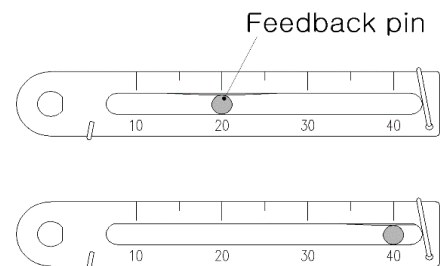

<Figure 2>



### 5700L bracket Installation

Assemble the positioner with the bracket made in previous step by fastening the bolts. Please refer to the backside of the positioner for size of the bolts. The standard bolt size is M8 x 1.25P.

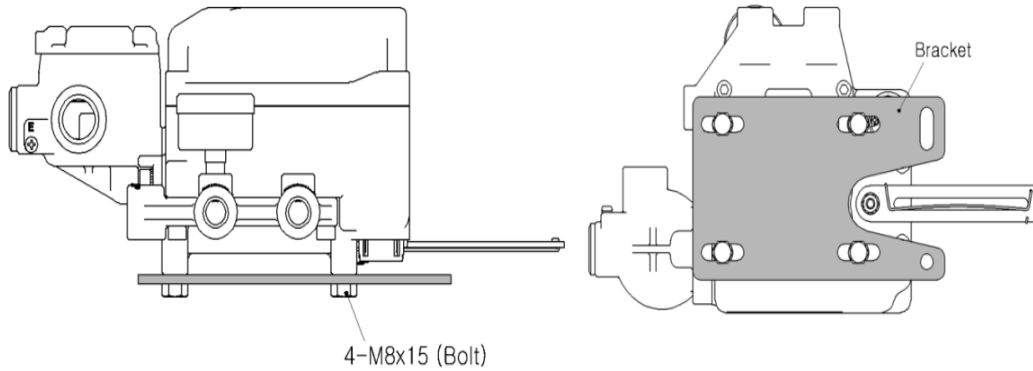

<5700L Bracket Installation Example>

---

**⚠ CAUTION**

---

- After installing the positioner, operate the valve from 0% to 100% stroke by using direct air to the actuator (manual position). On both 0% and 100%, the feedback lever should not touch the lever stopper, which is located on the backside of the positioner.
  - If the feedback lever touches the stopper, the positioner should be installed further away from the yoke.
- 

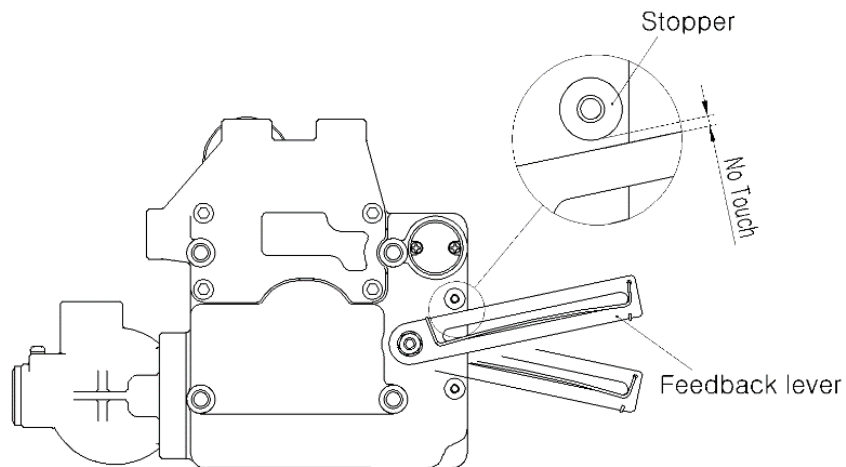

<5700L Feedback lever should not touch lever stopper>

### 3.3 5700R Installation

5700R Standard bracket (included with the positioner) contains two components. The bracket can be used for both fork lever and NAMUR lever type.

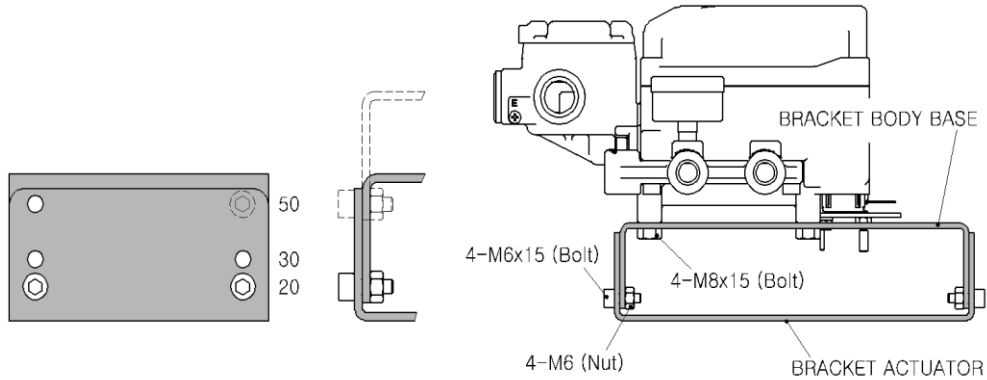

<5700R Bracket Install Example>

#### 3.3.1 Fork Lever Type

Install the fork lever to actuator as shown below. Install the positioner feedback shaft and actuator spindle so that the concentrically layered.

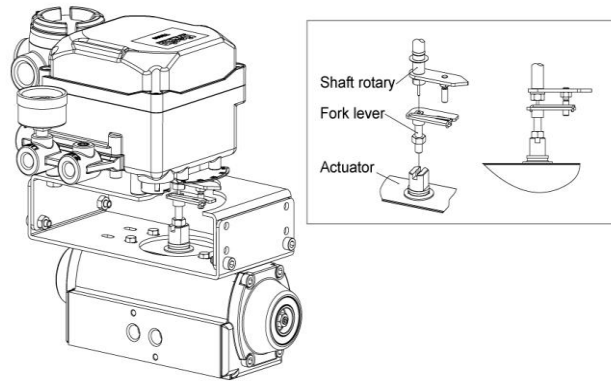

#### 3.3.2 NAMUR Type

Insert positioner feedback shaft and actuator spindle groove and tighten bracket.

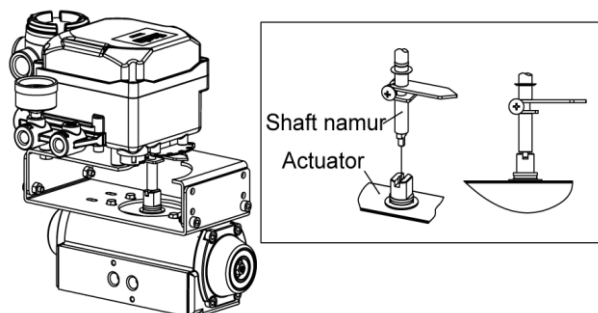

## 4 Air connection

### 4.1 Notice

---

**NOTICE**

---

- 57000 Series is designed to increase the input current signal and OUT1 port pneumatic output increases.
  - The products will be shipped RA (Reverse Action) that is when the input signal increases valves will be open.
  - If you want to use DA (Direct Action), must replace the pipe, span and pipeline route.
- 

### 4.2 5700L air connections

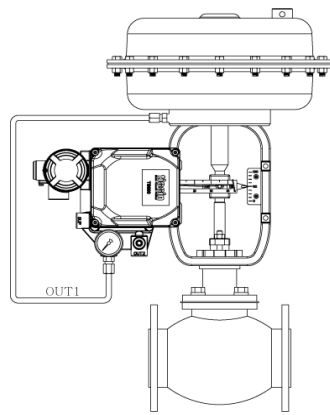

<5700L Single actuator>

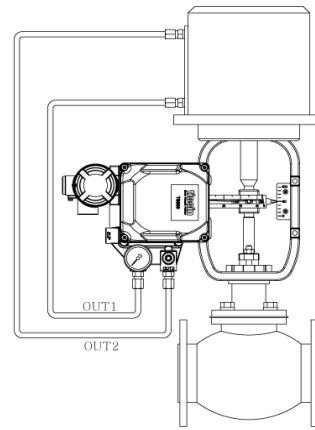

<5700L Double actuator>

### 4.3 5700L RA/DA action setting

For double acting, as shown below the piping connection and span position can be changed depends on RA/DA.

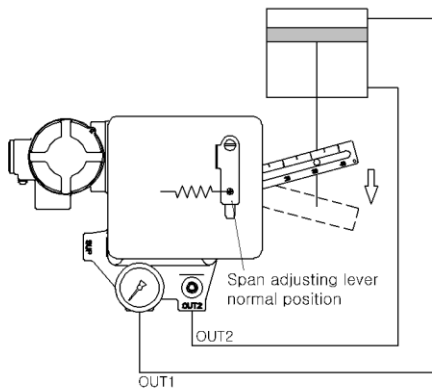

<Direct Action >

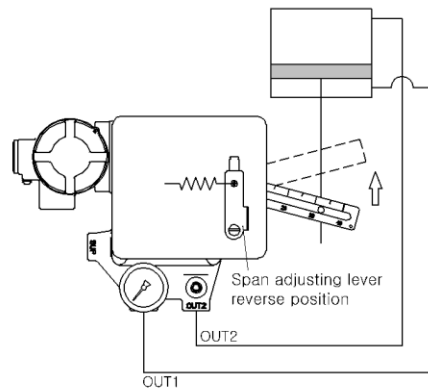

<Reverse Action>

#### 4.4 5700R air connections

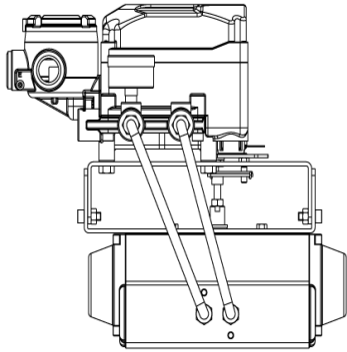

<5700R Double type actuator >

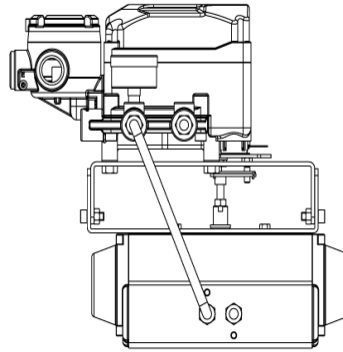

< 5700R Single actuator >

#### 4.5 5700R RA/DA action setting

If the valve is used for DA (Direct Action), the input signal will be increased. If cam is rotated counter-clockwise, RA will face up to the side of the cam. If cam is rotated clockwise, the DA will face up to the side of the cam.

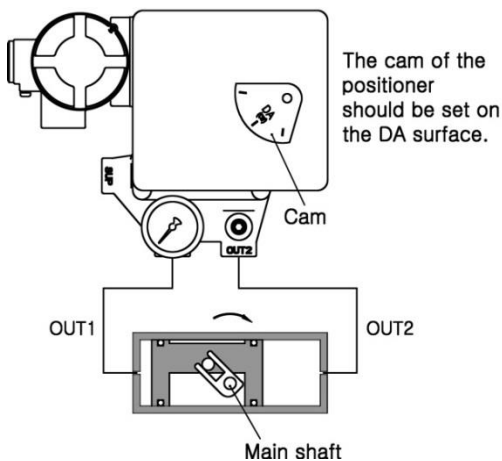

<DA Type>

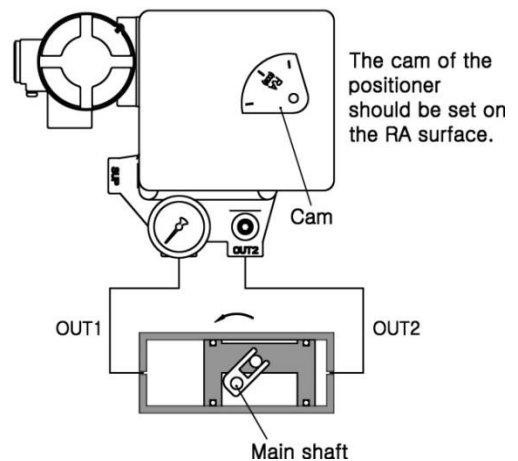

<RA Type>

## 5 Power Connection

---

### WARNING

---

- Always check that the electrical load is within the range stated on the nameplate. Failure to remain within electrical ratings may result in damage to or premature failure of the electrical switches, sensors or transmitter electronics.
  - Check polarity of + and – exactly and connect wires.
- 

### 5.1 Explosion proof type power connection

---

#### WARNING

---

- Be sure that exterior lead-in wiring to the terminal box is based on the guidelines for explosion-protection of manufactory electric equipment when being used as a flame proof, explosion proof construction.
  - Do not remove terminal cover in a hazardous location while the power is on.
  - Covers for the terminal and body should be in place while operating.
- 

#### Cable Gland Connection

- ① Be sure to use the flameproof-approved wires and cable glands in the gas area or in the potentially-explosive area. Use the cables suitable for the diameter of the NBR packing when using the flameproof-approved cable glands.
- ② Insert the terminal connection into terminal box and lock completely.
- ③ Insert washer and rubber packing, and fasten the cable gland completely.

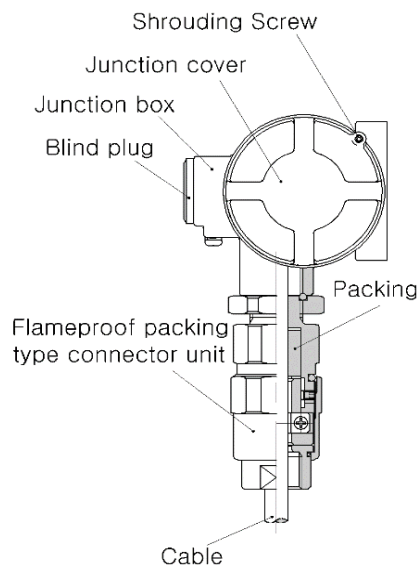

<Flameproof approved cable gland>

## Electrical Wiring

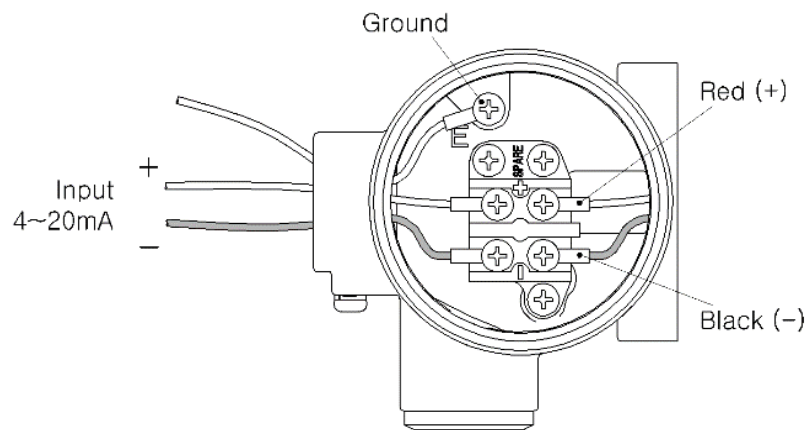

<Flameproof type Terminal box>

- ① Open terminal box cover.
- ② Locate the poles and connect them properly  
Make sure to fasten the connection.
- ③ Connect Ground cable.
- ④ Close back the terminal box cover

## 5.2 Intrinsically safe type power connection

---

### WARNING

---

5700 series are designed under intrinsically safe procedures and restriction. However, intrinsically safe system can be damaged from electronic energies from other electronic devices. To avoid any system damages, please read the following.

- Differentiate intrinsically safe type circuit with other types of circuit clearly.
  - Apply proper protection device to reduce frictions.
  - If possible, minimize the use of inductance and capacitance. If they must be used, set the devices at lower level than the maximum level.
  - Protect the wires from damages.
  - Grounding must be done properly according to the field's procedures.
- 

### Electrical Wiring

- ① Open the terminal box cover by loosening the fixing bolt on the terminal box cover.
- ② Connect external + to internal + and external – to internal.
- ③ Connect Ground Cable.
- ④ Close the terminal box cover and turn the fixing bolt completely.

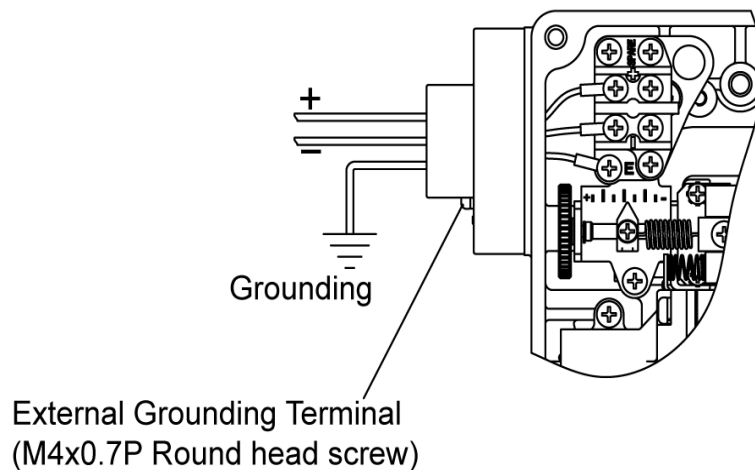

<Intrinsically safe type Terminal box>

### 5.3 With Position transmitter type power connection

---

**⚠ CAUTION**

---

- Be sure to connect the feedback circuit to DC voltage 10~30V.
  - Be sure to distinguish between the position of the current signal terminal and the position of the feedback signal terminal from the terminal block to connect (+) polarity and (-) polarity precisely.
- 

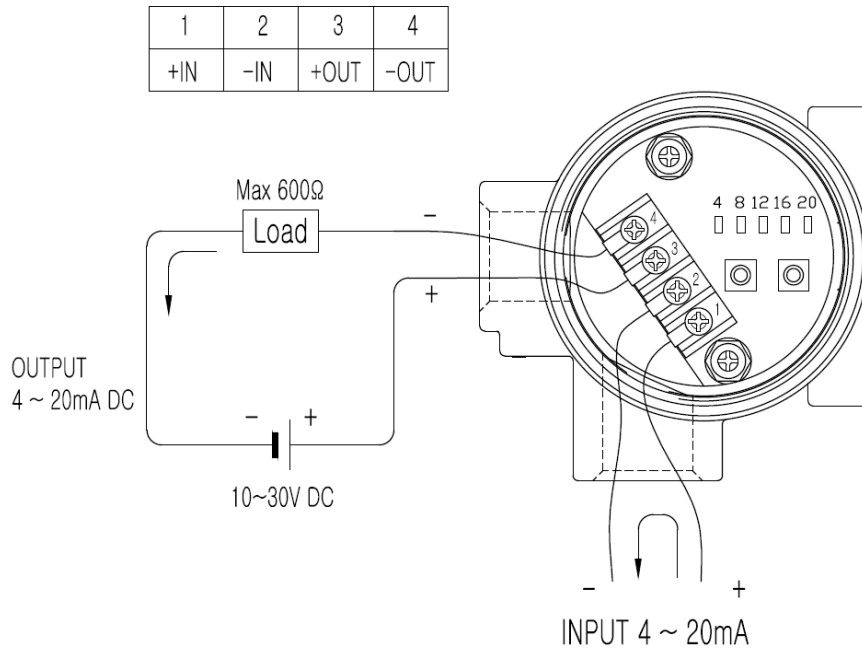

- ① Unlock the locking bolt of the terminal box and open the cover of the terminal box.
- ② Connect the electric wire (+) of the input signal to Number 1 of the terminal block and connect the electric wire (-) to Number 2 of the terminal block.
- ③ Connect the electric wire (+) of the feedback signal to Number 3 of the terminal block and connect the electric wire (-) to Number 4 of the terminal block.
- ④ Connect the ground to the ground terminal that is outside of the product.



## 6 Adjustment

---

### ⚠ CAUTION

---

Zero and span must be set correctly so product can be operated normally. If the setting is not correct, impact on performance like linearity and so on. Please the zero and span position must be set correctly.

---

### 6.1 Zero and Span Adjustment

- ① Set the input current to 4mA and turn the zero adjusting knob by hand to set it to the actuator starting 0% point.
- ② Then, set the input current to 20mA DC and check the actuator stroke. At this point, depending on whether the span is too large or too small loosen the lock screw and then adjust the span as shown in the illustration above, set it to the actuator 100% end point.
- ③ It shall set the input current to 0% and conduct the zero point adjustment, as done is step1 again, because Span and zero point adjustment interfere in each other.
- ④ Repeat the above operations until the predetermined stroke of the actuator is obtained to the input current.

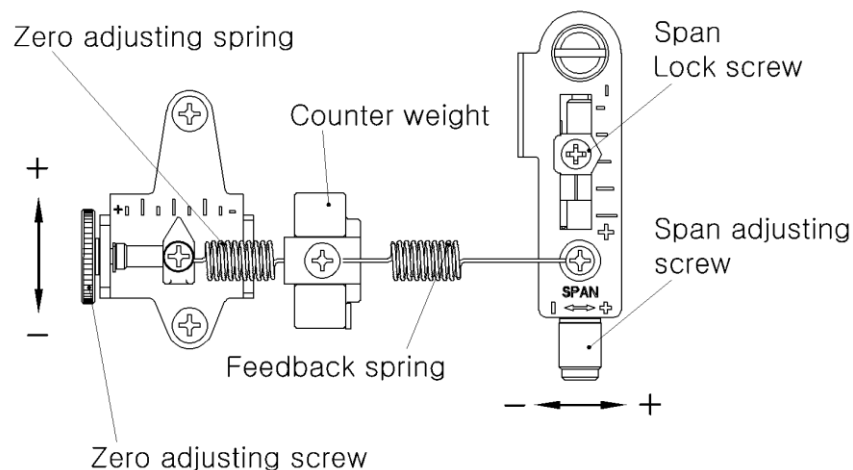

<Span and Zero structure>

## 6.2 Setting of the Position transmitter (Option)

For the general case, set 2 point that belongs to from 0% position to 100% position of the Valve. For more precise feedback, set 5 point.

### 2 points setting

- ① Input the current signal 4mA to make the valve stroke on 0% and then press the button with 4mA on the left for 2seconds, which can lead the setting lamp to turn on gradually and rapidly while the location information is saved automatically.
- ② Input the current signal 20mA to make the valve place on 100% and then press the button with 20mA on the right for 2 seconds, which can lead the setting lamp to turn on gradually and rapidly while the location information is saved automatically.

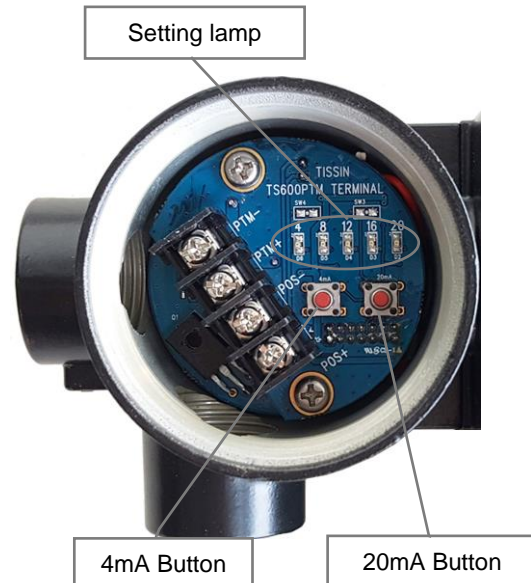

### 5 points setting

- ① First, input the current signal 4mA to make the valve stroke on 0% and then press the buttons with 4mA as well as 20mA for 2 seconds at the same time, which can lead the Number 4 setting lamp to blink.
- ② Pressing the button with 4mA just once makes that the valve is set to output 4mA value from 0% and moves to Number 8 lamp automatically and blinks.
- ③ Input the current signal 8mA to make the valve place on 25% and then press the button with 4mA just once, which can lead the valve to be set to output 8mA on the right position.
- ④ In the same way, set them in order to output 12mA, 16mA and 20mA according to each position of the valve 50%, 75% and 100%.
- ⑤ When 100% setting-up is completed, all the setting lamps get turned off.

### How to change DA/RA

This is the direction in which the feedback signal is changed.

When 4mA is inputted, get 20mA feedback. When 20mA is inputted, get 4mA feedback.

- ① Input the current signal 4mA to make the valve stroke on 0% and then press the button with 20mA for 2 seconds, which can lead the setting lamp to turn on gradually and rapidly while the location information is saved automatically.
- ② Input the current signal 20mA to make the valve stroke on 100% and then press the button with 4mA for 2 seconds, which can lead the setting lamp to turn on gradually and rapidly while the location information is saved automatically.

## 7 Troubleshooting

### 7.1 Common problems

Failure	The valve is fully open regardless of the input signal
Causes	The hole of A / M switch of pilot valve is blocked by foreign matter such as dust
Corrective Action	As shown below, loosen the stopper screw and separate A / M switch and clean the bottom of the hole with 0.2mm drill or wire and re-fitted as original.

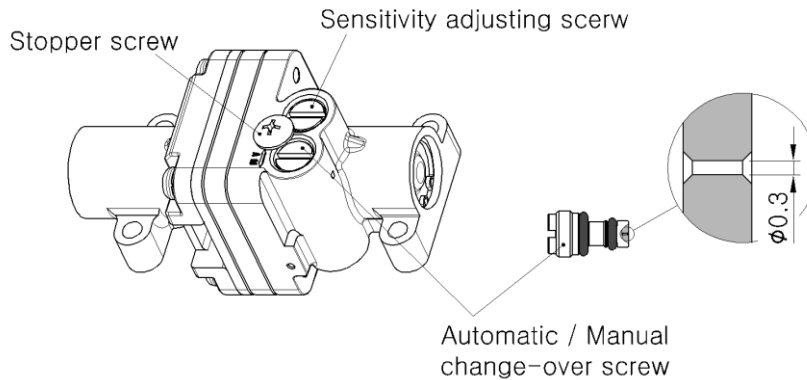

< A/M Switch Structure >

#### **⚠ CAUTION**

The sensitivity adjustment screw is set optimally at the factory, do not adjust at random.

### 7.2 Adjustment Orifice

Failure	When mounted on small size actuator (capacity less than 180cm <sup>3</sup> ) occurs hunting
Causes	The pneumatic output of the positioner is too large compared to the actuator chamber size.
Corrective Action	As shown below, remove the O-Ring at OUT1 on the bottom of the pilot, attach the bottom of the orifice included in the package.

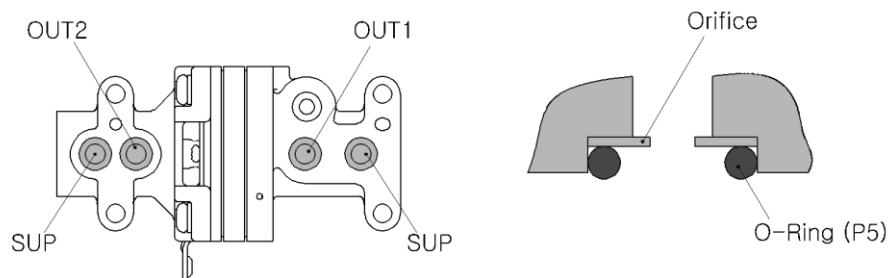

<Example of orifice installation>

### 7.3 Position transmitter

Phenomenon	Feedback signal dead zone
Cause	Potential meter gear breaks away by a strong shock or vibrates.
Explanation	The paint mark position of the upper part of the main shaft gear and the paint mark position of the upper part of the potential meter gear must coincide to become a normal state.

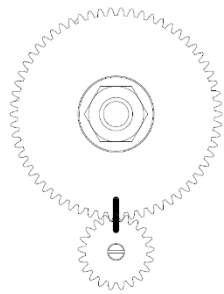

(Picture1) Normal condition

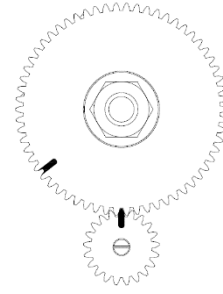

(Picture2) Gear breaks away

#### How to adjust when the gear breaks away

- ① Open the cover of the product. Unlock and take out one of 2 M3 fixing bolts for Potential meter. Unlock the other bolt just a little and then pull it down slightly, which can lead the potential meter gear to break away from the main shaft gear.
- ② When the carved positions are engaged each other, adjust the potential meter gear to put them on a straight line.
- ③ When the adjustment is completed, fix the potential meter with M3 bolt.

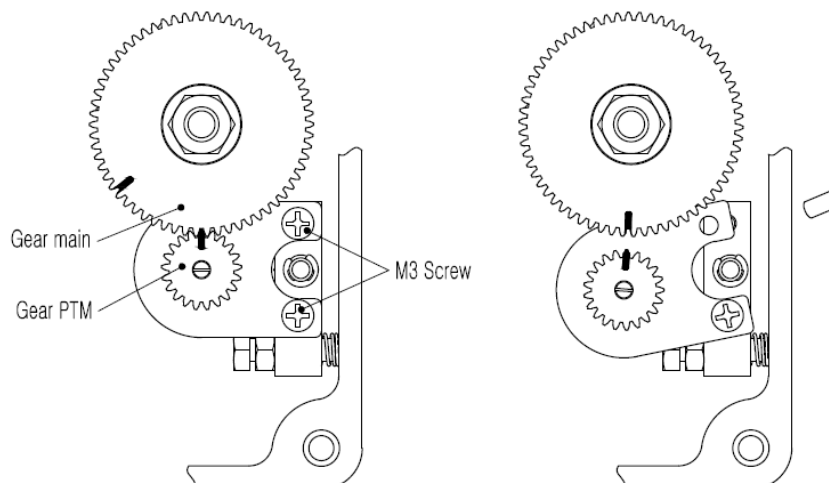

## 7.4 Other Problems and Resolution

### 👁 The positioner does not operate

Checklist	Causes	Corrective action	Reference page
If it does not work by moving the nozzle flapper	A/M switch is loose	Check to see if A/M switch is connected	27
	Nozzle clogged	Nozzle needs clean up	27
If it works by moving the nozzle flapper to the left and right	incorrect connections for input current	Check the wire connection	22~24

### 👁 The actuator works only with ON / OFF control and is not intermediate control.

Checklist	Causes	Corrective action	Reference page
Linear type, check span mounting	Span is mounted upside down	Turn the span body	19
Rotary type, check cam mounting	Cam is mounted upside down	Mount the cam correctly	20
Check OUT1, OUT2 pipeline	OUT1 and OUT2 pipeline connection is flipped	Install pipeline correctly	19~20

### 👁 Hunting occurs

Checklist	Causes	Corrective action	Reference page
Hunting period is too short and the width is too large (pressure gauge moves at the same time of valve stem)	Actuator volume is low	Install the orifice on the bottom part of the pilot	27
Hunting period is too short and the width is too big (Gauge markings move and valve stem slowly follow)	High temperature high pressure valve stem has a large frictional force	1 Perform a necessary action to minimize resistance of actuator or valve stem 2 Increase actuator size	N/A

### 👁 Linearity is too bad

Checklist	Causes	Corrective action	Reference page
Zero and span setting	zero and span setting is incorrect	Resetting zero and span	25
Check if input pressure is constant	Input pressure is not constant	Check the pressure relief valve on supply pressure is normal.	N/A
Verify lever installation	Lever does not provide optimum rotation angle	Adjust bracket and place drawbar on valve opening mark	17

### 👁 Hysteresis is too bad

Checklist	Causes	Corrective action	Reference page
Check connection of lever spring	Gap between the lever	Tighten the connection to remove the gap	16~17

## 8 Limited warranty and disclaimer

- The manufacturer warranty period of the product is 18 months after the product is shipped from Tissin in Korea.
- For any failure or damage reported within the warranty period which is clearly our responsibility, a replacement product or necessary parts will be provided. This limited warranty applies only to our product independently, and not to any other damage incurred due to the failure of the product.
- Using the device in a manner that does not fall within the scope of its intended use, disregarding this manual, using under qualified personnel, or making unauthorized alterations releases the manufacturer from liability for any resulting damage. This renders the manufacturer's warranty null and void.

## Note



4665 Interstate Drive \* Cincinnati, Ohio 45246  
PH# 513.731.2900 \* Fax# 513.731.6939  
[www.jflowcontrols.com](http://www.jflowcontrols.com)