



## **STANDARDS**

- Design & manufacture conform to API 599
- Test & inspect conform to API 598
- Flange dimensions conform to ASME B16.5
- Pressure-Temperature to ASME B16.34
- Firesafe conforms to API 607

# **DB5500 Series**

## **Double Block & Bleed Plug Valves**

### **FEATURES & BENEFITS**

- Face-to-face dimension is factory standard
- Bleed port
- Choice of mounting positions for actuators and handwheels
- In-line sealant inject point
- Bleed valve flange interface
- In-line emergency stem sealing
- Compact, lightweight alternative to gate valves and ball valves

### **APPLICATIONS & INDUSTRIES**

- Compressors & Pumps Isolations
- Critical Bypass
- Vents
- Drains & Blow-downs to Atmosphere
- Water/Slurry/Gas Injection System Isolations
- Critical Applications

## FEATURES & BENEFITS

### Single Plug - Single Isolation

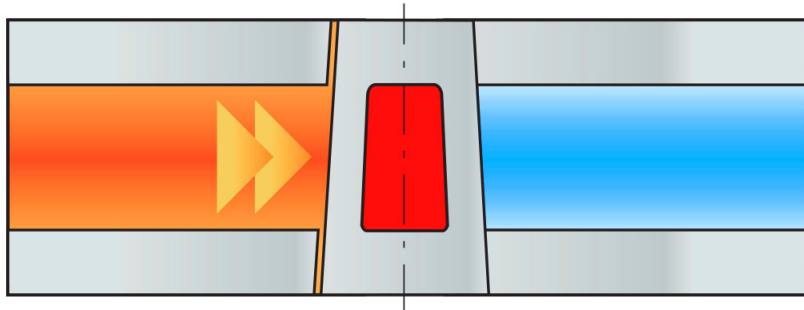

### Double Plug - Double Isolation

Independently operated plugs mean maximum downstream isolation safety

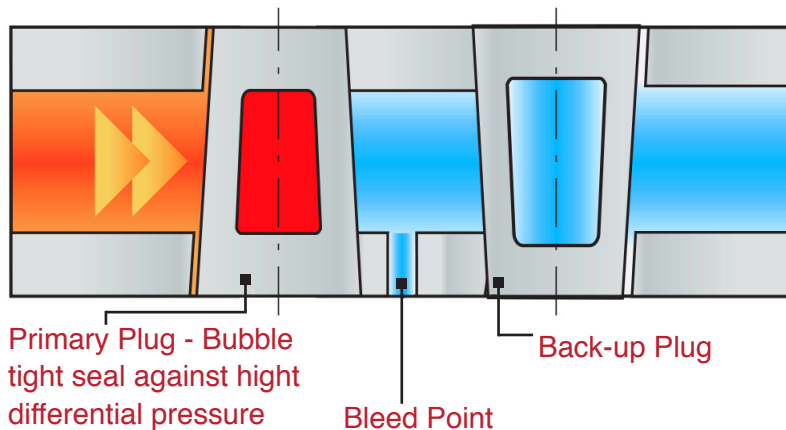

- Face-to-face dimension is factory standard
- No pipework modification - total interchangeability with existing valves
- Choice of bleed connection options
- Same range as single valve including hard facing
- Meets the same industry and fire-test standards as a single valve
- Low life cycle cost - less than two single valves
- Assured sealing on both sides of the valve
- Reduced leak paths - eliminates inter-valve pipework on double block and bleed configurations
- Compact, lightweight alternative to gate valves and ball valves.

## DB5500 Series Double Block & Bleed Plug Valve

### Range

API 6D Dimensions	in	1/2	3/4	1	1-1/2	2	3	4	6	8	10	12	14	16	18	20	24
	mm	15	20	25	40	50	80	100	150	200	250	300	350	400	450	500	600
PN20 - ANSI 150		✓	✓	✓	✓	✓	✓	✓	✓	✓	✓	✓	✓	✓	✓	✓	✓
PN50 - ANSI 300		✓	✓	✓	✓	✓	✓	✓	✓	✓	✓	✓	✓	✓	✓	✓	✓
PN100 - ANSI 600		✓	✓	✓	✓	✓	✓	✓	✓	✓	✓	✓	✓	✓	✓	✓	✓
PN150 - ANSI 900		✓	✓	✓	✓	✓	✓	✓	✓	✓	✓	✓	✓	✓	✓	✓	✓
PN250 - ANSI 1500		✓	✓	✓	✓	✓	✓	✓	✓	✓	✓	✓	✓	✓	✓	✓	✓
PN420 - ANSI 2500		✓	✓	✓	✓	✓	✓	✓	✓	✓	✓	✓	✓	✓			
API 2000						✓	✓	✓	✓								
API 3000						✓	✓	✓	✓								
API 5000						✓	✓	✓	✓								
API 10000						✓	✓	✓	✓								
API 15000						✓	✓	✓	✓								
API 6A Dimensions	in					2 1/16	3 1/8	4 1/16	7 1/16								
	mm					52	78	103	179								

## Why Select A Plug Valve

Robust metal-to-metal seats cope well with the solid impurities that can run at high velocities in close proximity to the integral seating surfaces, particularly when the valve is opened against a high differential pressure (Figure 1)



Figure 1

Robust metal-to-metal seats have high resistance to solid objects and lack of gap/cavity between plug and body ensure that particles do not become trapped between plug and body thus avoiding damages to the seats while closing the valve (Figure 2)

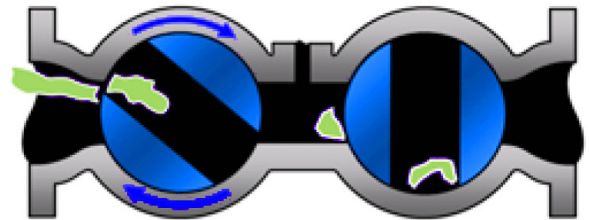

Figure 2

Large seating area enhances the DIPV resistance to erosion. The wide area maximizes the effectiveness of sealant, so that if the valve starts passing it can quickly be solved by injecting Serck Aduco Sealant, restoring the valve's bubble tight shut-off capabilities without the need of the overhaul. Sealant can be injected with the valve in any position and also under pressure, making the valve in-line maintainable. (Figure 3)

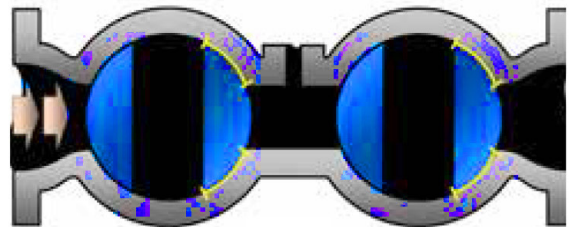

Figure 3

When the valve is open, unlike in other valve designs, the seats are well protected from the line media. This ensures that even if the valve is left open for long periods of time, its seating areas will not get damaged, thus ensuring good sealing and long valve life. (Figure 4)

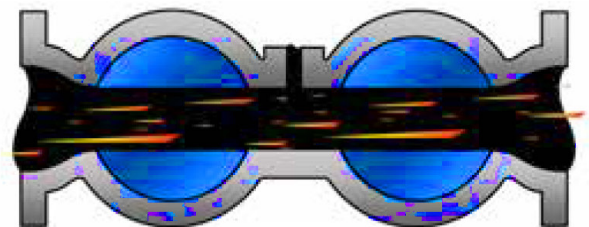

Figure 4

## MAIN FEATURES

### Principles of Operation

The DB5500 Series Plug Valve features two separate protected pressure balanced taper plugs and a centrally located bleed port, integral with the body. They are designed to give bubble tight shutoff on both high and low pressure applications. This is a robust, in-line maintenance valve with low maintenance requirements. The valve body is a rigid, single piece casting. The blowout proof valve stems are fugitive emission tested. The separate plugs are retained in the body by separate bolted covers. The design incorporates provision for external maintenance of the individual stem packings.

### Plug Balancing

All DIPV valves are protected against the possibility of seizure due to taper locking. Taper locking is caused by an imbalance of forces acting on the plug due to line pressure finding its way into the large end of the plug chamber. As shown in the arrows in Fig.1, the resultant force tends to push the plug upwards, jamming it in its tapered bore. The plug can remain locked even when line pressure is subsequently reduced.

In an attempt to combat taper locking, conventional valves utilize the pressure of the plug sealant, acting on the upper face of the plug, to react against the upwards force. This reduced, but does not eliminate, the possibility of taper locking - and requires regular sealant injection to maintain valve freedom.

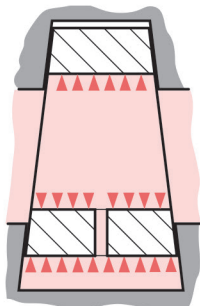

Figure 1

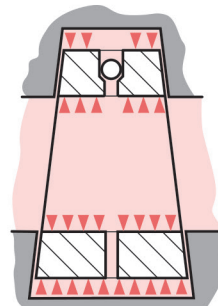

Figure 2

### Pressure Balancing

Pressure balanced plug valves incorporate pressure balanced plugs, as shown in Fig. 2. The drilling and check valve in the top section of the plug allow the line pressure itself to counteract the upwards force, preventing any possibility of taper locking - without the need for frequent sealant injection.

### Emission Control

Industry standards are tightening the requirements on emission levels permitted from pressurized equipment. DIPV valves are ahead and are designed and tested to meet the most stringent fugitive emission requirements. Our adjustable gland design, combined with high performance graphite stem packing materials, ensures low emissions over extensive temperature and mechanical cycling, even without the use of o-rings or PTFE seals.

# DB5500 Series Double Block & Bleed Plug Valve

## DIMENSIONS

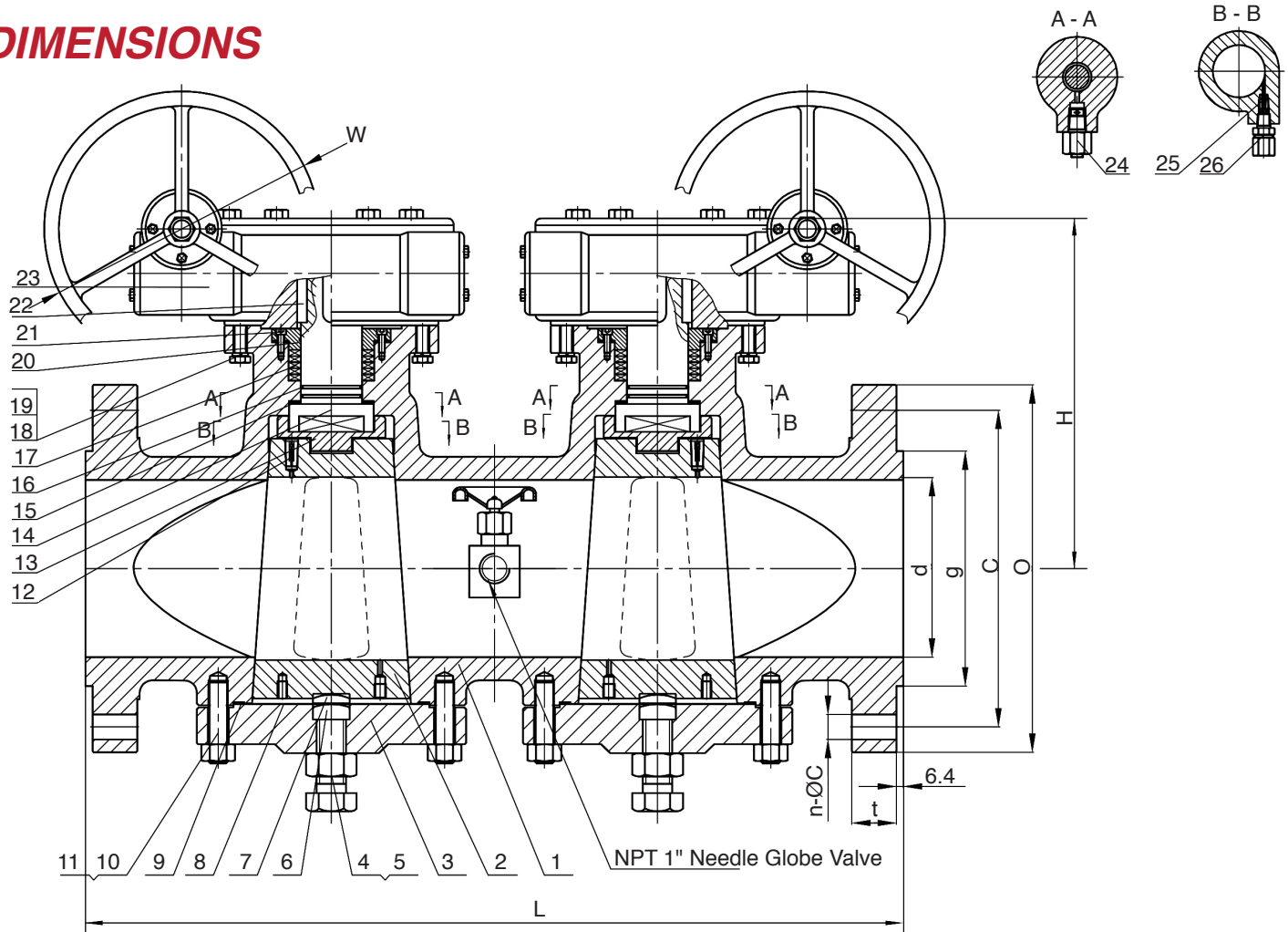

Size	d	L	O	C	g	t	n-ØC	H	W
16	375	1480	686	603	470	77	20 - 41	620	550
20	464	1700	813	724	584	89	24 - 44	650	600

Item	Part Name	Materials	Item	Part Name	Material
1	Body	A1216 WCC	14	Stem	4140
2	Plug	A105+N	15	Gasket	PTFE
3	Cover	A216 WCC	16	O-Ring	Viton
4	Nut	A194 2H	17	Packing	Graphite
5	Bolt	A193 B7	18	Blot	AISI 1035
6	Adjustable Block	A276 410	19	Spring Washer	AISI 1566
7	Adjustable Block	A276 410	20	Gland	A216 WCB
8	Metal Diaphragm	SS304	21	Blot	A193 B7
9	Gasket	SS304+Graphite	22	Key	AISI 1045
10	Nut	A194 2H	23	Gear Operator	Assembly
11	Blot	A193 B7	24	Emergency Device	
12	Check Valve	Assembly	25	Check Valve	
13	Coupler	A276 410	26	Grease Fitting	

**J Flow® Controls**  
 4665 Interstate Drive  
 Cincinnati, OH 45246  
 513-330-6354  
 jflowcontrols.com

While the information and specifications contained in this literature are believed to be accurate, they are supplied for informative purposes only and should not be considered certified or a guarantee of satisfactory results. Nothing contained herein is to be construed as a warranty or guarantee, express or implied, regarding any matter with respect to this product. Because J Flow Controls is continually improving and upgrading its product design, the specifications, dimensions and information contained herein are subject to change without notice.