

KB Series Low Pressure Gate Valve

200WOG
SIZE: 1/2"-3"



SPECIFICATION

- * Body & end caps quality investment casting
- * 200 WOG working pressure
- * Size range: 1/2" to 3"
- * Non-rising stem, non-rising handwheel

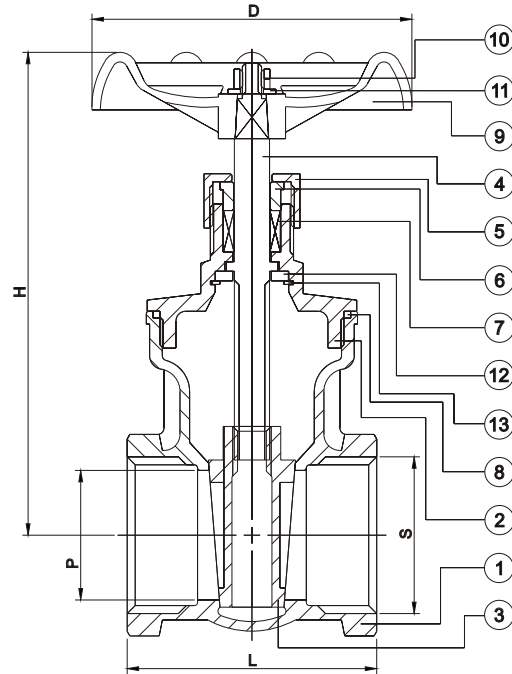

DIMENSIONS (inch)

SIZE	P	L	H	D	S+0.5
1/2"	0.63	2.24	3.98	2.44	0.86
3/4"	0.80	2.38	4.25	2.44	1.07
1"	1.02	2.64	4.65	2.91	1.33
1-1/4"	1.25	2.99	5.08	2.91	1.68
1-1/2"	1.50	3.43	6.81	3.74	1.92
2"	1.90	3.70	7.32	3.94	2.41
2-1/2"	2.44	4.57	10.24	4.76	-
3"	2.99	5.16	11.61	4.76	-

MATERIALS LIST

ITEM	PART NAME	MATERIALS
1	BODY	CF8M
2	BONNET	CF8M
3	DISC	CF8M
4	STEM	SS 316
5	GLAND NUT	CF8M
6	GLAND	CF8M
7	PACKING	PTFE
8	GASKET	PTFE
9	HANDWHEEL	FC 20
10	NUT	SS 304
11	WASHER	SS 304
12	WASHER	SS 304
13	C-SNAP RING	SS 301

PRESSURE/ TEMPERATURE (BODY)

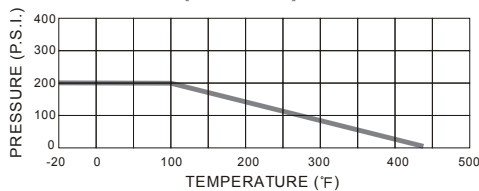

ORDERING SCHEMATIC

Series	Body / Plug	Port	Packing	Seat	Ends
KB	33 316 SS	F Full	T PTFE Teflon	M Metal	S Threaded



The Right Valve • The Right Application • Right now!

J Flow Controls, LLC
14 De Camp • Cincinnati, OH 45216
Phone: 513-731-2900 • Fax 513-731-6939
www.jflowcontrols.com