



## **STANDARDS**

- API Standard: API 600, API 6D
  - Flange Dimension: ASME B16.5, ASME B16.47
  - Face-to-Face Dimension: ASME B16.10, API 6D
  - Test & Inspect: API 598, API 6D
- DIN Standard: DIN 3352
  - Flange Dimension: DIN 2543, 2544, 2546
  - Face-to-Face Dimension: DIN 3202 F4/F5
  - Test & Inspect: DIN 3230

# **KO Series Gate Valves**

## **FEATURES & BENEFITS**

- Can be designed and manufactured either to API standard dimensions or DIN dimensions
- Special requirements by the customer can be accommodated
- Wall thickness: ANSI B16.34
- Flanged finish: MSS SP-6

## **APPLICATIONS & INDUSTRIES**

- Cryogenics
- Pulp & Paper
- Petrochemical Plants
- Petroleum Refining
- Fossil Power Plants
- Nuclear Power Plants

## KO Series Gate Valves

### PARTS IDENTIFICATION

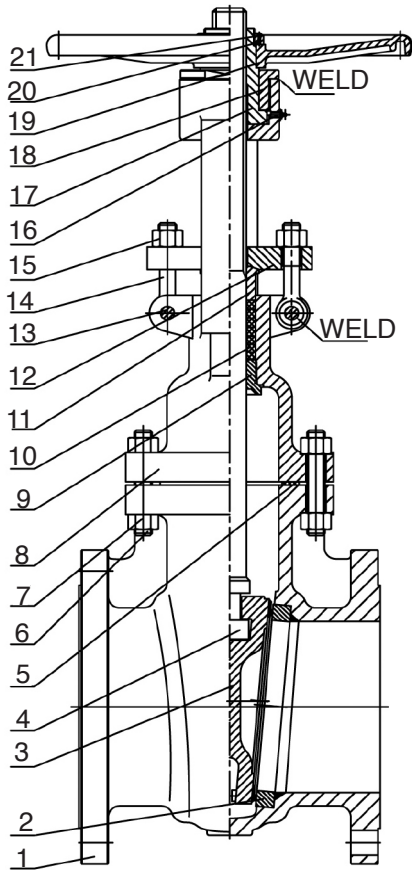

No	Part Name	Material
1	Body	ASTM A216 WCB
2	Seat	ASTM A105 + Steel
3	Wedge	ASTM A216
4	Stem	WCB + Steel
5	Gasket	ASTM A182 F6a
6	Bolt	Graphite + 304
7	Nut	ASTM A103 B7
8	Bonnet	ASTM A194 2H
9	Back Seat	ASTM A216 WCB
10	Packing	ASTM A182 F6a
11	Gland	Graphite
12	Gland Flange	ASTM A276 410
13	Pin	ASTM A216 WCB
14	Eyelet Bolt	ASTM 1035
15	Nut	ASTM A193 B7
16	Oil Cup	ASTM A194 2H
17	Stem Nut	Brass
18	Gland	ASTM C95200
19	Handwheel	ASTM 1025
20	Screw	ASTM 32510
21	Handwheel Nut	ASTM A1025

### ENGINEERING

Nominal Pressure	Shell Test		Waster Seal Test		Air Seal Test	
	Mpa	LBf/in <sub>2</sub>	Mpa	LBf/in <sub>2</sub>	Mpa	LBf/in <sub>2</sub>
150	3.0	430	2.2	315	0.4 - 0.7	60 -100
300	7.7	1110	5.7	815		
600	15.3	2220	11.3	1630		

## KO Series Gate Valves

### API STANDARD DIMENSIONS

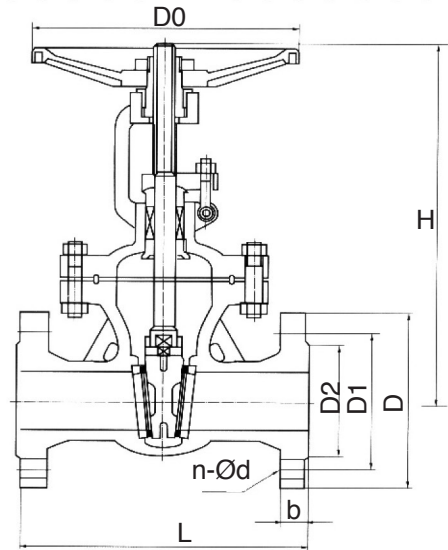

Size	300 LB RF							
Inches	L	D	D1	D2	b	n-ØD	H	D0
1/2	4.29	3.53	2.40	1.39	0.40	0.16-0.64	6.71	3.97
3/4	4.64	3.89	2.78	1.71	0.42	0.16-0.64	7.62	3.97
1	5.04	4.29	3.14	2.02	0.46	0.16-0.64	9.13	4.76
1-1/4	5.56	4.64	3.53	2.54	0.52	0.16-0.64	9.77	4.76
1-1/2	6.55	5.04	3.91	2.90	0.58	0.16-0.64	11.2	5.95
2	7.07	6.03	4.79	3.65	0.64	0.16-0.75	12.8	7.94
2-1/2	7.54	7.07	5.55	4.17	0.71	0.16-0.75	13.8	7.94
3	8.06	7.54	6.05	5.04	0.77	0.16-0.75	15.2	9.92
4	9.09	9.09	7.56	6.23	0.95	0.32-0.75	18.1	11.1
5	10.1	10.1	8.58	7.38	0.95	0.32-0.89	25.1	11.1
6	10.6	11.1	9.58	8.58	1.01	0.32-0.89	25.2	11.9
8	11.6	13.6	11.9	10.7	1.13	0.32-0.89	30.3	13.9
10	13.1	16.1	14.4	12.9	1.20	0.48-1.01	35.4	15.9
12	15.1	19.2	17.1	15.1	1.27	0.48-1.01	42.9	17.9
14	16.1	21.2	18.9	16.4	1.39	0.48-1.15	51.4	19.9
16	17.2	23.7	21.4	18.7	1.45	0.64-1.15	57.0	19.9
18	18.2	25.2	22.9	21.2	1.57	0.79-1.27	64.6	19.9
20	20.2	27.8	25.2	23.2	1.71	0.79-1.39	64.7	23.8
24	22.2	32.3	29.8	27.5	1.94	0.79-1.39	86.4	23.8
26	24.2	31.2	29.6	27.8	2.03	1.43-0.89	88.7	25.8
28	24.2	33.2	31.6	30.3	1.77	1.59-0.89	91.7	27.8
30	27.8	35.2	33.6	32.3	1.77	1.75-0.89	107	27.8
32	28.2	37.4	35.7	34.3	1.83	1.91-0.89	147	--
36	30.6	42.0	40.1	38.6	2.08	1.59-1.01	156	--
40	32.2	46.7	44.5	42.9	2.21	1.75-1.01	171	--

## KO Series Gate Valves

### API STANDARD DIMENSIONS

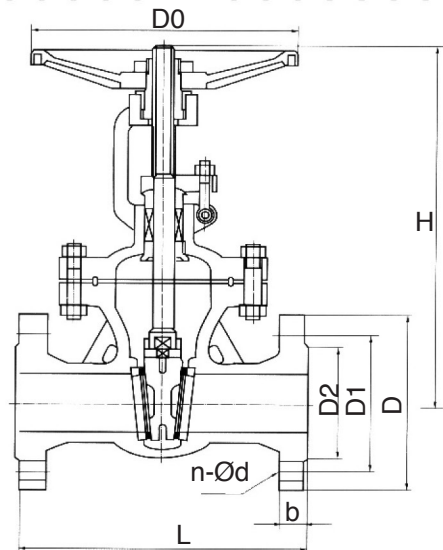
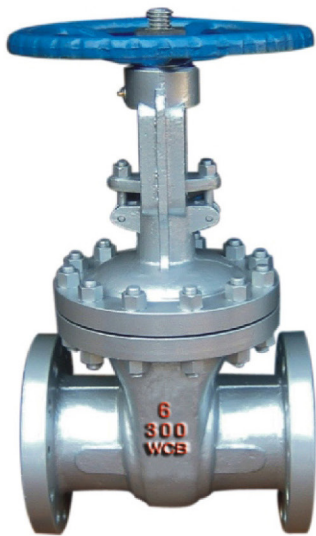

Size	300 LB RF							
Inches	L	D	D1	D2	b	n-ØD	H	D0
1/2	5.56	3.77	2.64	1.39	0.56	0.16-0.64	6.71	4.76
3/4	6.03	4.64	3.28	1.71	0.64	0.16-0.75	7.66	5.95
1	6.55	4.88	3.53	2.02	0.69	0.16-0.75	9.13	5.95
1-1/4	7.07	5.28	3.91	2.50	0.75	0.16-0.75	9.77	6.35
1-1/2	7.54	6.15	4.54	3.02	0.82	0.16-0.89	11.2	7.15
2	8.58	6.55	5.04	3.65	0.89	0.32-0.75	13.1	7.94
2-1/2	9.57	7.54	5.93	4.17	1.01	0.32-0.89	14.6	7.94
3	11.2	8.34	6.67	5.04	1.13	0.32-0.89	15.6	9.92
4	12.1	10.1	7.95	6.23	1.26	0.32-0.89	18.8	11.1
5	15.1	11.1	9.33	7.38	1.39	0.32-0.89	26.2	11.9
6	16.0	12.6	10.7	8.58	1.45	0.48-0.89	28.2	13.9
8	16.6	15.1	13.1	10.7	1.64	0.48-1.01	32.3	15.9
10	18.1	17.6	15.4	12.9	1.90	0.64-1.13	39.8	17.9
12	19.9	20.7	17.9	15.1	2.02	0.64-1.27	45.1	19.9
14	30.3	23.2	20.4	16.4	2.14	0.79-1.27	59.1	23.8
16	33.3	25.7	22.7	18.7	2.27	0.79-1.39	63.1	25.8
18	36.3	28.2	25.0	21.2	2.40	0.95-1.39	80.1	27.8
20	39.3	30.8	27.2	23.2	2.52	0.95-1.39	88.5	27.8
24	45.4	36.3	32.3	27.5	2.78	0.95-1.63	105	29.8
26	49.4	34.4	31.9	29.2	3.57	1.27-1.39	127	29.8
28	53.4	36.6	34.0	31.3	3.57	1.43-1.39	134	--
30	55.5	39.3	35.8	33.5	3.72	1.43-1.51	140	--

## KO Series Gate Valves

### DIN STANDARD DIMENSIONS

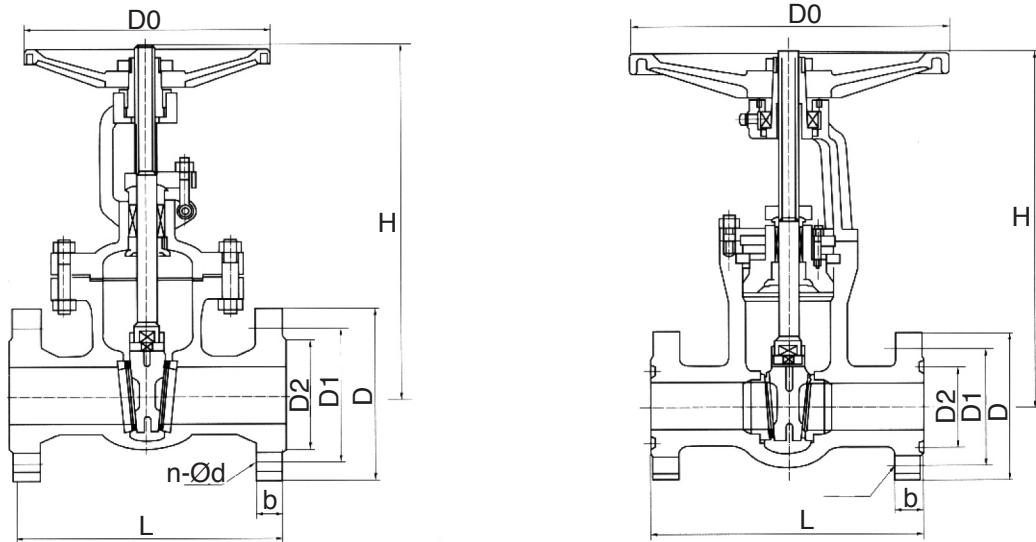

Size	600 LB RF							
Inches	L	D	D1	D2	b	n-ØD	H	D0
1/2	6.55	3.77	2.64	1.39	0.83	0.16-0.64	6.71	6.35
3/4	7.54	4.64	3.28	1.71	0.89	0.16-0.75	7.66	7.40
1	8.58	4.92	3.53	2.02	0.95	0.16-0.75	9.13	7.94
1-1/4	9.09	5.28	3.91	2.50	1.09	0.16-0.75	9.77	7.94
1-1/2	9.57	6.19	4.54	2.90	1.15	0.16-0.89	11.2	9.53
2	11.6	6.55	5.04	3.65	1.27	0.32-0.75	16.9	7.94
2-1/2	13.1	7.54	5.93	4.17	1.39	0.32-0.89	19.3	9.92
3	14.1	8.34	6.67	5.04	1.53	0.32-0.89	20.3	11.1
4	17.2	10.8	8.58	6.23	1.77	0.32-1.01	24.2	11.9
5	20.2	13.1	10.6	7.38	2.02	0.32-1.13	27.8	13.9
6	22.2	14.1	11.6	8.58	2.16	0.48-1.13	32.6	17.9
8	26.2	16.6	13.9	10.7	2.46	0.48-1.27	36.5	19.9
10	31.2	20.2	18.3	12.9	2.78	0.64-1.39	42.9	25.8
12	33.3	22.2	19.4	15.1	2.90	0.79-1.39	48.4	29.8
14	35.3	23.9	20.9	16.4	3.04	0.79-1.51	58.5	31.8
16	39.3	27.2	24.0	18.7	3.28	0.79-1.63	65.5	35.7
18	43.4	29.5	26.0	21.2	3.53	0.79-1.77	68.6	--
20	47.4	32.3	28.7	23.2	3.79	0.95-1.77	80.2	--
24	55.5	37.3	33.3	27.5	4.29	0.95-2.02	85.6	--

## KO Series Gate Valves

### DIN STANDARD DIMENSIONS

Size		L		D	D1	D2	b	f	z-Ød	H/H1	W
PN	Inches	F4	F5								
16	2	5.91	9.84	6.50	4.92	4.02	0.79	0.12	0.16-0.71	12.2	9.45
	2-1/2	6.69	10.6	7.28	5.71	4.80	0.71	0.12	0.16-0.71	14.4	9.45
	3	7.09	11.0	7.87	6.30	5.43	0.79	0.12	0.31-0.71	15.6	11.0
	4	7.48	11.8	8.66	7.09	6.22	0.79	0.12	0.31-0.71	16.7	12.6
	5	7.87	12.8	9.84	8.27	7.40	0.87	0.12	0.31-0.71	18.9	14.2
	6	8.27	13.8	11.2	9.45	8.35	0.87	0.12	0.47-0.87	20.5	14.2
	8	9.06	15.8	13.4	11.6	10.6	0.94	0.12	0.47-1.02	24.4	15.8
	10	9.84	17.7	15.9	14.0	12.6	1.02	0.16	0.47-1.02	28.0	17.7
	12	10.6	19.7	18.1	16.1	14.9	1.10	0.16	0.47-1.02	29.9	22.1
	14	11.4	21.7	20.5	18.5	17.2	1.18	0.16	0.63-1.02	35.4	25.2
	16	12.2	23.6	22.8	20.7	19.3	1.26	0.16	0.63-1.18	39.4	25.2
	20	13.8	27.6	28.2	25.6	24.0	1.42	0.16	1.18-1.30	48.2	27.6
24	15.4	31.5	33.1	30.3	28.5	1.57	0.20	0.79-1.42	53.5	27.6	
25	2	5.91	9.84	6.5	4.92	4.02	0.79	0.12	0.16-0.71	12.2	9.45
	2-1/2	6.69	10.6	7.28	5.71	4.80	0.87	0.12	0.31-0.71	14.4	9.45
	3	7.09	11.0	7.87	6.30	5.43	0.94	0.12	0.31-0.71	15.6	11.0
	4	7.48	11.8	9.25	7.48	6.38	0.94	0.12	0.31-0.87	16.7	12.6
	5	7.87	12.8	10.6	8.66	7.40	1.02	0.12	0.31-1.02	18.9	14.2
	6	8.27	13.8	11.8	9.84	8.58	1.10	0.12	0.31-1.02	20.5	14.2
	8	9.06	15.8	14.2	12.2	10.9	1.18	0.12	0.47-1.02	24.4	15.8
	10	9.84	17.7	16.7	14.6	13.2	1.26	0.12	0.47-1.18	28.0	17.7
	12	10.6	19.7	19.1	16.9	15.6	1.34	0.16	0.63-1.18	29.9	22.1
	14	11.4	21.7	21.9	19.3	17.7	1.50	0.16	0.63-1.30	35.4	25.2
	16	12.2	23.6	24.4	21.7	19.9	1.57	0.16	0.63-1.42	39.4	25.2
	20	13.8	27.6	28.7	26.0	24.2	1.73	0.16	0.79-1.42	48.2	27.6
24	15.4	31.5	33.3	30.3	28.4	1.81	0.20	0.79-1.54	53.5	27.6	
40	2	5.91	9.84	6.5	4.92	4.02	0.79	0.12	0.16-0.71	12.2	9.45
	2-1/2	6.69	10.6	7.28	5.71	4.80	0.87	0.12	0.31-0.71	14.4	9.45
	3	7.09	11.0	7.87	6.30	5.53	0.94	0.12	0.31-0.71	15.6	11.0
	4	7.48	11.8	9.25	7.09	6.38	0.94	0.12	0.31-0.87	16.7	12.6
	5	7.87	12.8	10.6	8.66	7.40	1.02	0.12	0.31-1.02	18.9	14.2
	6	8.27	13.8	11.8	9.84	8.58	1.10	0.12	0.31-1.02	20.5	14.2
	8	9.06	15.8	14.8	12.6	11.2	1.34	0.12	0.47-1.18	24.4	15.8
	10	9.84	17.7	17.7	15.2	13.6	1.50	0.12	0.47-1.30	28.0	17.7
	12	10.6	19.7	20.3	17.7	16.1	1.65	0.16	0.63-1.30	29.9	22.1
	14	11.4	21.7	22.8	20.1	18.3	1.81	0.16	0.63-1.42	35.4	25.2
	16	12.2	23.6	23.6	23.0	21.1	1.97	0.16	0.63-1.54	39.4	25.2
	20	13.8	27.6	29.7	26.4	24.2	2.05	0.16	0.79 - 1.65	48.2	27.6
24	15.4	31.5	35.0	31.3	28.9	2.36	0.20	0.79-1.89	53.5	27.6	

## KO Series Gate Valves

### DIN STANDARD DIMENSIONS (Con't)

Size		L		D	D1	D2	b	f	z-Ød	H/H1	W
PN	Inches	F4	F5								
<b>60</b>	<b>2</b>	5.91	9.84	7.09	5.31	4.02	1.02	0.12	0.16-0.87	12.2	9.45
	<b>2-1/2</b>	6.69	10.6	8.07	6.30	4.80	1.02	0.12	0.31-0.87	14.4	9.45
	<b>3</b>	7.09	11.0	8.46	6.69	5.43	1.10	0.12	0.31-0.87	15.6	11.0
	<b>4</b>	7.48	11.8	9.84	7.87	6.38	1.18	0.12	0.31-1.02	16.7	12.6
	<b>5</b>	7.87	12.8	11.6	9.45	7.40	1.34	0.12	0.31-1.18	18.9	14.2
	<b>6</b>	8.27	13.8	13.6	11.0	8.58	1.42	0.12	0.31-1.30	20.5	14.2
	<b>8</b>	9.06	15.8	16.3	13.6	11.2	1.65	0.12	0.47-1.02	24.4	15.8
	<b>10</b>	9.84	17.7	18.5	15.8	13.6	1.81	0.12	0.47-1.02	28.0	17.7
	<b>12</b>	10.6	19.7	20.9	18.1	16.1	2.05	0.16	0.47-1.02	29.9	22.1
	<b>14</b>	11.4	21.7	23.6	20.7	18.3	2.20	0.16	0.63-1.02	35.4	25.2

### HOW TO ORDER

Series	Body Material	Trim Material	Flanged End Connections
<b>KO</b>	<b>2CS</b> Carbon Steel	<b>SS</b> Stainless Steel	<b>F150</b> ANSI 150
	<b>3SS</b> 316 Stainless Steel	<b>22</b> Chrome Trim	<b>F300</b> ANSI 300
	<b>3SS</b> 304 Stainless Steel	<b>#1</b> 410 trim	<b>F600</b> ANSI 600
	<b>0LF2</b> LF2 Low Temp Carbon	<b>#4</b> Hard 410	
	<b>0LCC</b> LCC Low Temp Carbon	<b>#8</b> 410 Hard faced	
	<b>2WCC</b> Alloy Steel		
	<b>2WC6</b> Alloy Steel		



4665 Interstate Drive  
Cincinnati, OH 45246  
513-330-6354  
[jflowcontrols.com](http://jflowcontrols.com)

While the information and specifications contained in this literature are believed to be accurate, they are supplied for informative purposes only and should not be considered certified or a guarantee of satisfactory results. Nothing contained herein is to be construed as a warranty or guarantee, express or implied, regarding any matter with respect to this product. Because J Flow Controls® is continually improving and upgrading its product design, the specifications, dimensions and information contained herein are subject to change without notice.