

STANDARDS

- ISO 5211 Direct Mount Design
- ANSI Class 150, 300, 600 and 900
- Standard ISA 75.04 face-to-face;
Option: ANSI B16.10 short pattern

DM9900 Series

Segmented V-Port Control Valve

FEATURES & BENEFITS

- Size range 1-1/2" - 30"
- Flanged and flangeless versions available
- Live loaded packing
- Protected bearings, top & bottom
- Easy installation and versatility
- Extremely low actuator torque
- Reduced trim option
- WCB, 316SS, 317SS and other alloy materials
- Soft seated and metal seated
- Patents pending

APPLICATIONS & INDUSTRIES

- Fibers
- Chemical fluids with suspended solids
- Dirty, clean, viscous and corrosive fluids
- Gas
- Steam
- Pulp and paper
- High temperature

DESCRIPTION

The segmented V-port ball control valve provides excellent modulating control with obstruction-free design.

The uni-body construction provides increased structural integrity and minimized leaks through body joints.

The specially designed compound V opening provides precise equal percentage flow control with small incremental opening in the lower end of the valve rotation and high flow capacity in the upper end. The nearly wide open at full open, along with recessed bearings, virtually eliminates plugging/clogging of the valve



OPERATION

The valve can be direct mounted (no mounting bracket or coupling) to:

- J-Flow's JFD spring & diaphragm actuators
- J-Flow's JFC rack & pinion actuators, or
- J-Flow's JFE electric actuators

They can be controlled with a variety of J-Flow positioners:

- Pneumatic
- Electro-pneumatic
- Digital smart

There are two actuator mounting options

- The standard connection is direct mount a compatible with any ISO 5211 standard actuator.
- Optional splined connection for the installation of diaphragm actuators with DSY-DSZ conversions

DESIGN & CONSTRUCTION

The valve's design allows control of the most fluids used in many industries. The valve is suitable for fibers, particles in suspension, dirty, clean viscous and corrosive fluids, gas, steam and especially pulp and paper applications.

The valve can be supplied with a variety of actuators, positioners, limit switches/transmitters or other topworks accessories



STANDARD SEATS

TFM, suitable to temperatures of 500°F for general services where ANSI Class VI shutoff is required to comply with ANSI / FCI 70-2 (see graph below)

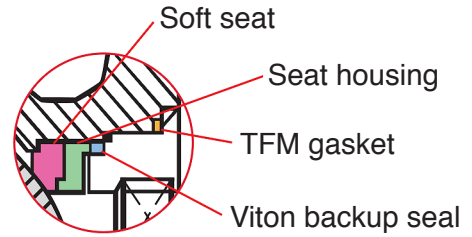

METAL-TO-METAL CONTACT SEATS

Suitable for erosive services, fiber, chemical fluids with suspended solids, and high temperature applications.

Metal seat with hardened stellite contact surface and 316 stainless steel segmented ball with tungsten carbide coating ANSI Class IV shutoff

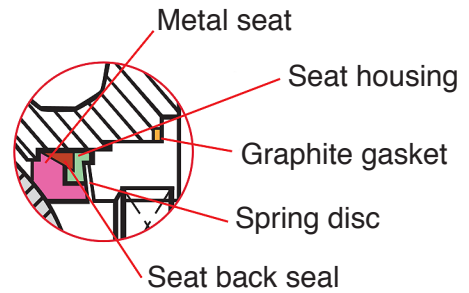

PRESSURE TEMPERATURE CHARTS

ANSI 150 Soft Seat

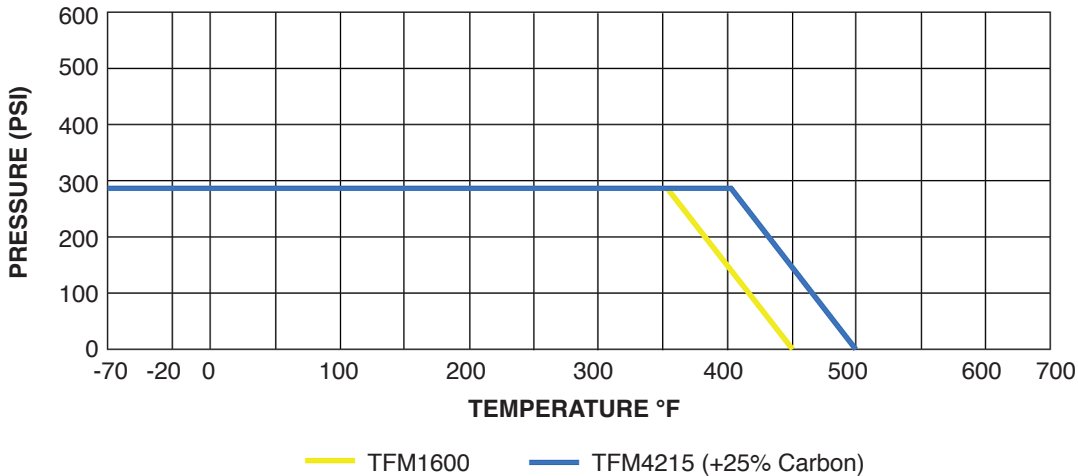

ANSI 150 Metal Seat

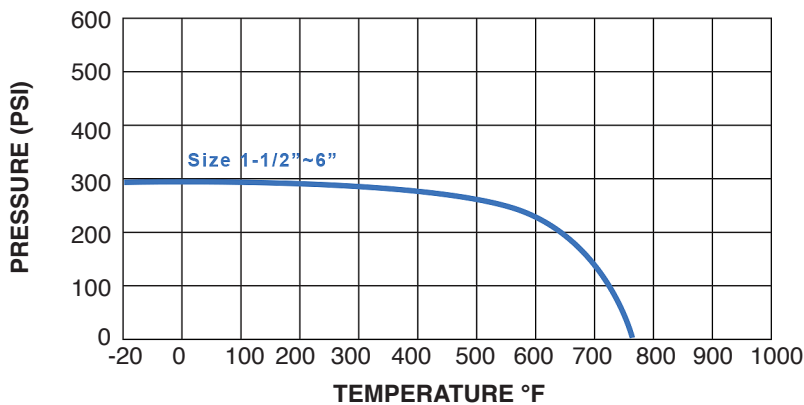

DM9900 Series Segmented V-Port Control Valve

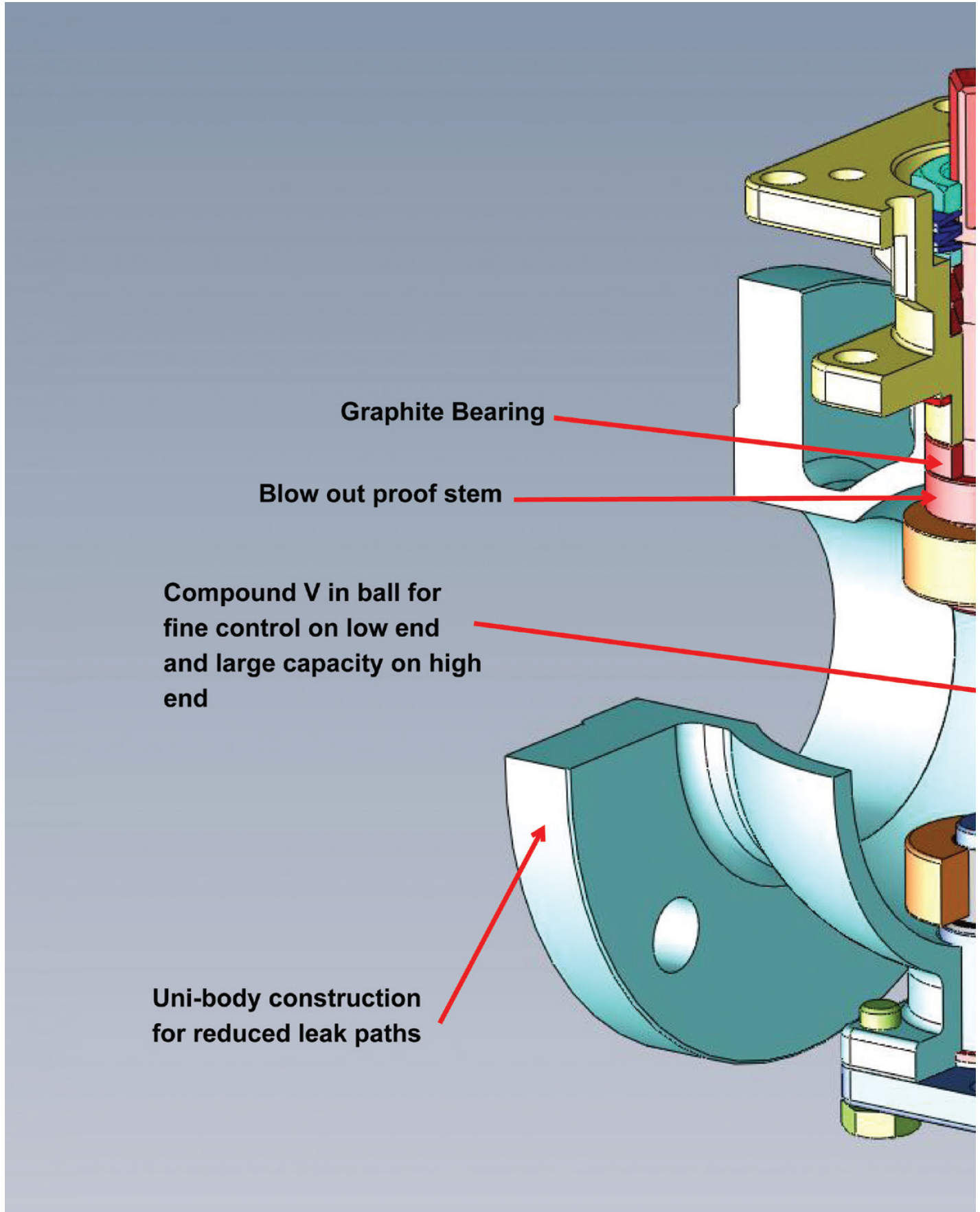

DM9900 Series Segmented V-Port Control Valve

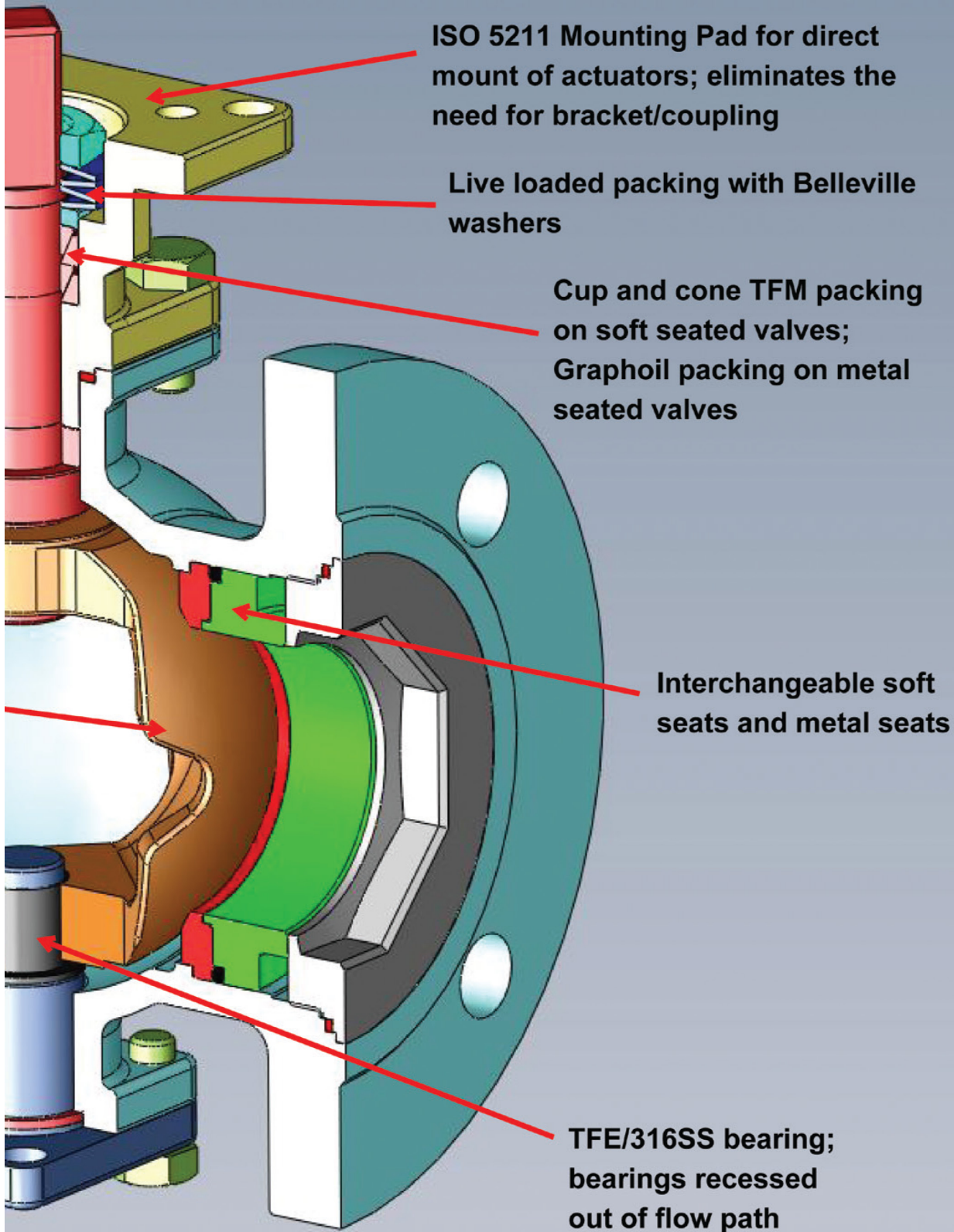

DM9900 Series Segmented V-Port Control Valve

DM9900F SERIES - SIZE AND CLASS (1-1/2" - 12")

Nominal Diameter		DM9900 Series Flanged	9900 Series Wafer		Cv Max
inches	mm		Class 150	Class 300	
1-1/2	40				80
2	50				102
3	80				340
4	100				650
6	150				845
8	200				1690
10	250				2690
12	300				4440

The segmented V-port ball valve can be used in modulating control services or "on-off" services

ACTUATOR SIZING TORQUE

DM9900 Soft Seats

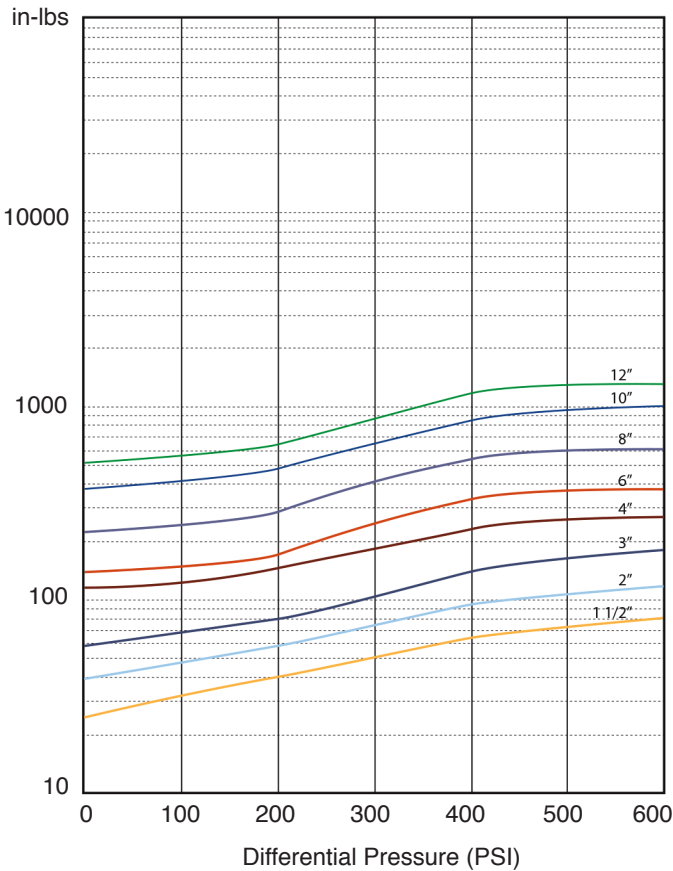

DM9900 Soft Seats

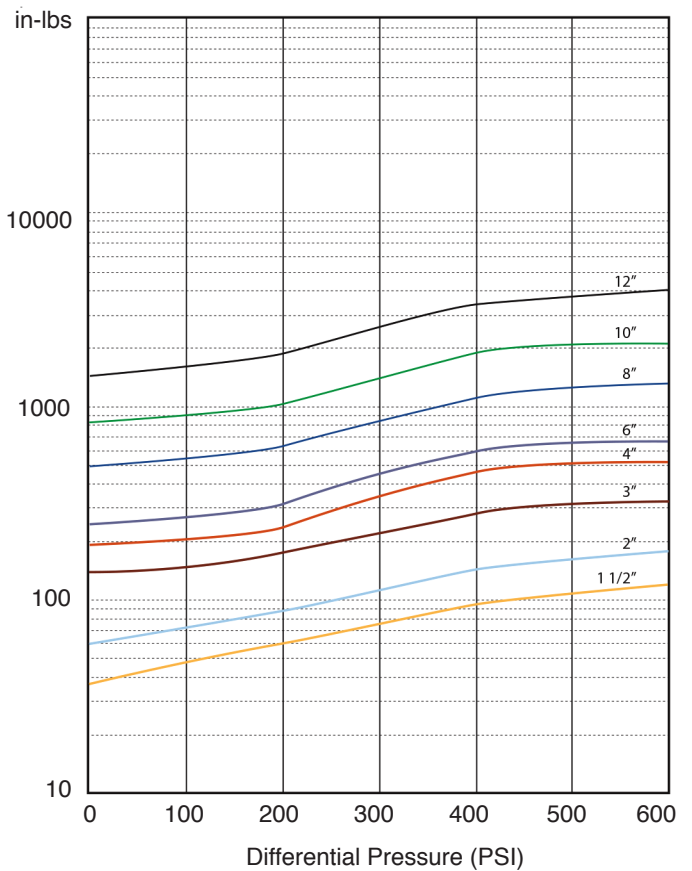

Torque is based on clean, clear liquid

DM9900 Series Segmented V-Port Control Valve

DIMENSIONS: 1-1/2" - 6" ANSI 150 FLANGED

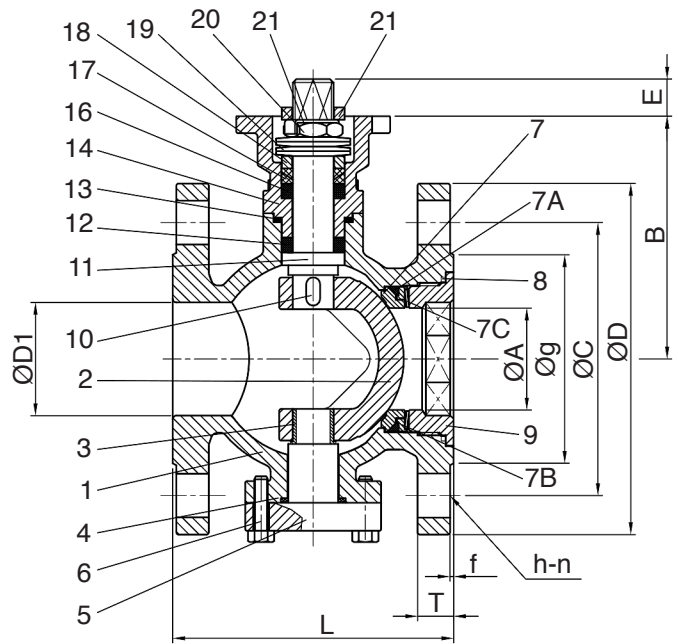
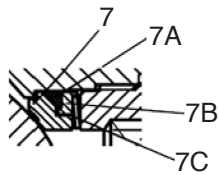
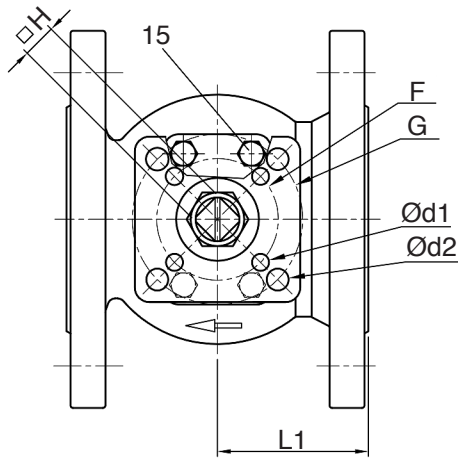

Metal Seat Detail

Part No.	Name of Parts	Materials
1	Body	A351 Gr. CF8M
2	Ball Segment	CF8M (Hardened - N)
3	Bearing	17-4PH
4	Gasket	Graphite
5	Trunnion Cap	A351 Gr. CF8M
6	Trunnion Cap Bolts	SS 304
7	Seat	SS316 + Stellite
7A	Seat Back Seal	Graphite
7B	Seat Housing	SS 316
7C	Spring Disk	SS 301
8	Insert Gasket	Graphite
9	Insert Cap	A351 Gr. CF8M
10	Key	SS 316
11	Stem	SS 316
12	Bearing	Graphite
13	Bonnet Gasket	Graphite
14	Bonnet	A351 Gr. CF8M
15	Bonnet Bolts	SS 304
16	Bearing	Graphite
17	Stem Packing	Graphite
18	Gland	SS 304
19	Belleville Washer	SS 301
20	Stem Nut	SS 304
21	Nut Stop	SS 304
22	Space Washer	SS 304

Soft Seat

Part No.	Name of Parts	Materials
1	Body	A351 Gr. CF8M
2	Ball Segment	A351 Gr. CF8M
3	Bearing	PTFE + 50% SS
4	Gasket	TFM 1600
5	Trunnion Cap	A351 Gr. CF8M
6	Trunnion Cap Bolts	SS 304
7	Seat	TFM 1600
7A	Seat Housing	SS 316
7B	Back-up seal	Viton (O-ring)
8	Insert Gasket	TFM 1600
9	Insert Cap	A351 Gr. CF8M
10	Key	SS 316
11	Stem	SS 316
12	Bearing	TFM 4215
13	Bonnet Gasket	TFM 1600
14	Bonnet	A351 Gr. CF8M
15	Bonnet Bolts	SS 304
16	Bearing	TFM 4215
17	Stem Packing	TFM 1600
18	Gland	SS 304
19	Belleville Washer	SS 301
20	Stem Nut	SS 304
21	Nut Stop	SS 304
22	Space Washer	SS 304

DM9900 Series Segmented V-Port Control Valve

DIMENSIONS: 1-1/2" - 6" ANSI 150 FLANGED

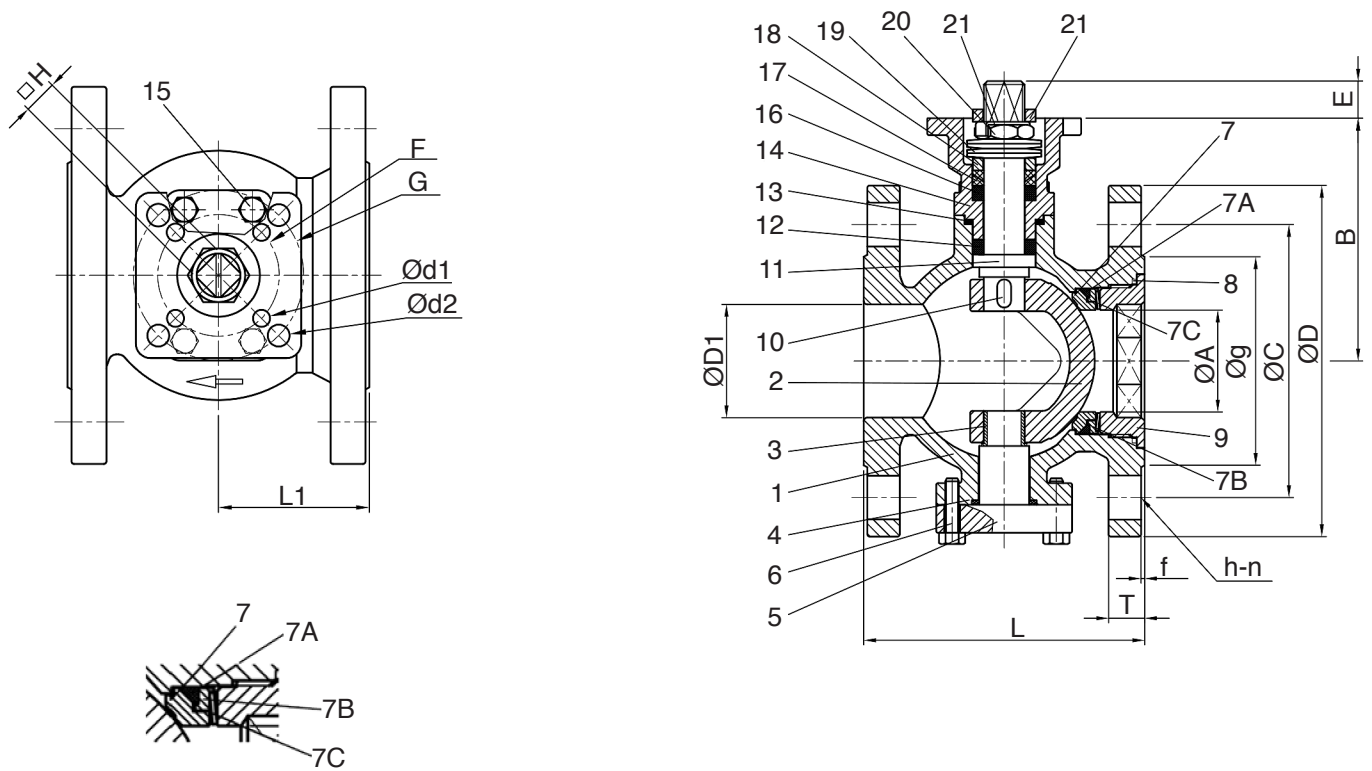

Metal Seat Detail

Valve Size	A	B	E	L		L1	H	D1	F	G	d1	d2
				ISA	Class 150							
1-1/2"	1.378	4.213	0.55	4.50	6.50	2.244	0.551	1.496	1.969	2.756	0.276	0.362
2"	1.772	4.213	0.55	4.88	7.00	2.441	0.551	1.969	1.969	2.756	0.276	0.362
3"	2.598	5.520	0.94	6.50	8.00	3.425	0.669	3.248	2.756	4.016	0.362	0.449
4"	3.157	6.087	0.94	7.62	9.00	4.047	0.669	3.839	2.756	4.016	0.362	0.449
6"	4.488	7.559	1.02	9.00	10.50	4.881	0.866	6.024	4.016	4.921	0.449	0.531

Valve Size	Flange Dimensions (Class 150)						
	D	Bolt Hole			t	g	f
		C	h	n			
1-1/2"	5.0	3.88	0.625	4	0.56	2.88	0.06
2"	6.0	4.75	0.750	4	9.62	3.62	0.06
3"	7.5	6.0	0.750	4	0.75	5.00	0.06
4"	9.0	7.5	0.750	8	0.94	6.19	0.06
6"	11.0	9.5	0.875	8	1.00	8.50	0.06

DM9900 Series Segmented V-Port Control Valve

DIMENSIONS: 8" - 12" ANSI 150 FLANGED (SOFT SEAT)

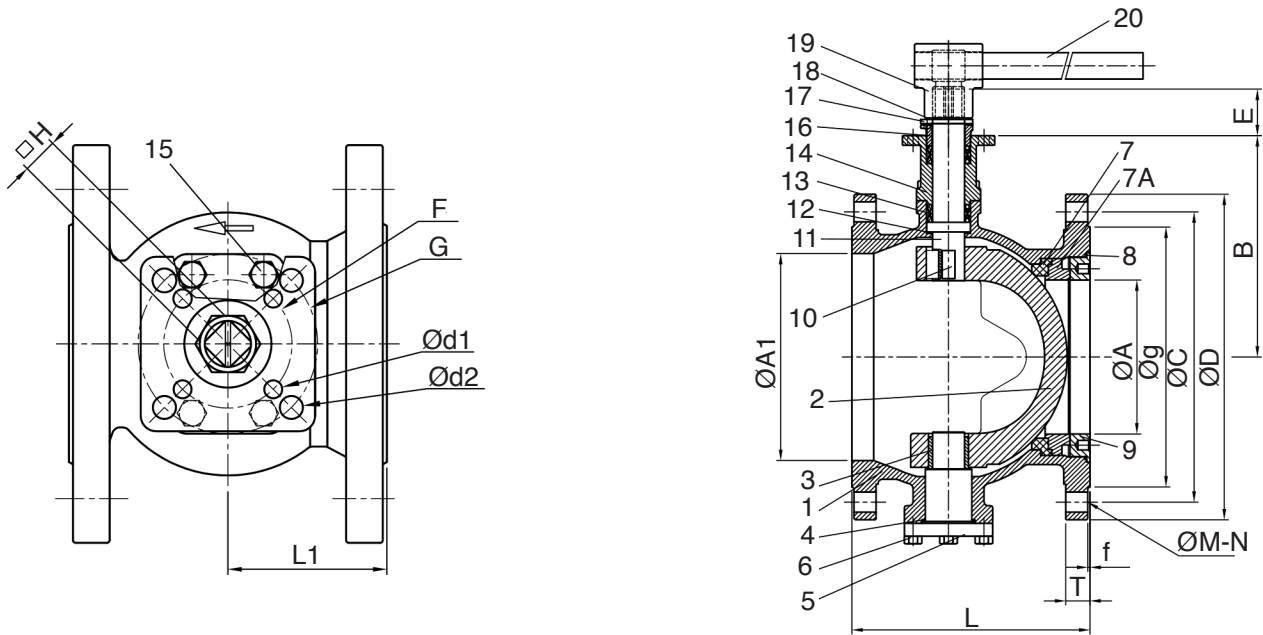

Part No.	Name of Parts	Material Options	
1	Body	A351 Gr. CF8M	A216 Gr. WCB
2	Ball Segment	A351 Gr. CF8M	---
3	Bearing	PTFE + 50% SS	---
4	Gasket	TFM 1600	---
5	Trunnion Cap	A351 Gr. CF8M	A216 Gr. WCB
6	Trunnion Cap Bolts	SS 304	---
7	Seat	TFM 1600	---
7A	Seat Housing	SS 316	A216 Gr. WCB
8	Insert Gasket	TFM 1600	---
9	Insert Cap	A351 Gr. CF8M	A216 Gr. WCB
10	Key	SS 316	---
11	Stem	SS 316	---
12	Thrust Washer	TFM 1600	---
13	Bearing	TFM 4215	---
14	Bonnet	A351 Gr. CF8M	A216 Gr. WCB
15	Bonnet Bolts	SS 304	---
16	Gland	A351 Gr. CF8M	---
17	Stop	SS 304	---
18	Stop Ring	SS 304	---
19	Handle Head	FCD45	---
20	Handle Tube	Carbon Steel	---

DM9900 Series Segmented V-Port Control Valve

DIMENSIONS: 8" - 12" ANSI 150 FLANGED (SOFT SEAT)

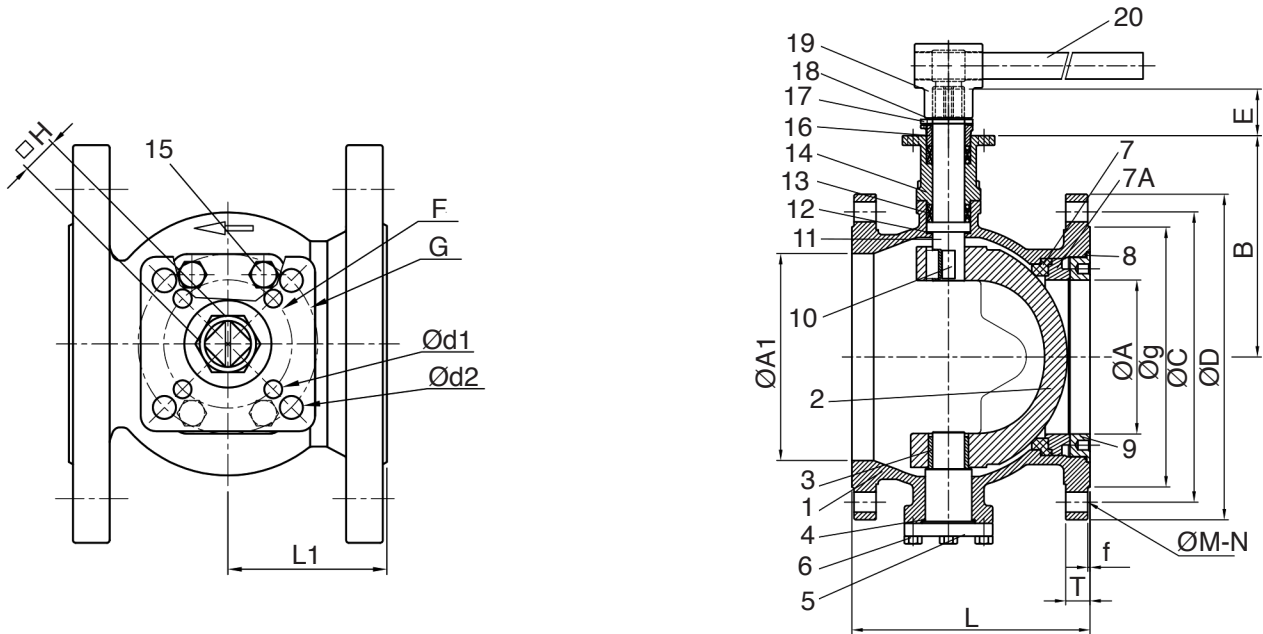

Valve Size	A	A1	B	E	L	L1	H	F	d1
8"	5.98	8.07	9.45	2.28	9.56	5.51	1.102	4.92	M12
10"	7.56	10.20	10.87	2.28	11.69	6.93	1.102	4.92	M12
12"	8.66	11.81	//11.89	2.52	13.31	8.15	1.417	5.51	M16

Valve Size	Flange Dimensions (Class 150)						
	D	Bolt Hole			t	g	f
		C	h	n			
8"	13.5	11.75	0.875	8	1.14	10.63	0.06
10"	16.0	14.25	1.000	12	1.20	12.75	0.06
12"	19.0	17.00	1.000	12	1.26	15.00	0.06

DM9900 Series Segmented V-Port Control Valve

HOW TO ORDER

Series	Body	Trim	Port	Packing	Seat	End Connections
DM99	2 WCB	3 316SS	F Full	G Graphoil	M Metal	F1 ANSI 150 (ISA 75.04 f to f)*
	3 316SS	4 Alloy 20	R Reduced	TM TFM 1600	TM TFM 1600	F3 ANSI 300 (ISA 75.04 f to f)*
	4 Alloy 20	6 317SS		TC TFM 4215	TC TFM 4215	F6 ANSI 600 (ISA 75.04 f to f)*
	6 317SS	7 Hastelloy C				F9 ANSI 900 (ISA 75.04 f to f)*
	7 Hastelloy C	9 Duplex				
	9 Duplex					

* Option ANSI B16.10 short pattern f to f



4665 Interstate Drive
Cincinnati, OH 45246
513-330-6354
jflowcontrols.com

While the information and specifications contained in this literature are believed to be accurate, they are supplied for informative purposes only and should not be considered certified or a guarantee of satisfactory results. Nothing contained herein is to be construed as a warranty or guarantee, express or implied, regarding any matter with respect to this product. Because J Flow Controls® is continually improving and upgrading its product design, the specifications, dimensions and information contained herein are subject to change without notice.