

STANDARDS

- API 6D certified
- API 6FA
- Fire Safe to API 607, 4th Edition
- Designed in accordance with API-6D, ASME B16.34, NACE, and BS5351 specifications
- Double block and bleed

9700 Series Trunnion Ball Valve

FEATURES & BENEFITS

- Sizes 2" to 60"
- Bolted forged body
- Trunnion mounted
- Wide seat-sealing contact area
- Fire safe
- Piston-action SR (self-relieving) seats
- Spring-energized seats for sealing at low line pressure
- O-ring stem seals - double barrier
- Secondary stem sealant injection (2" and above)
- Secondary soft-seat sealant injection (6" and above)
- Double block-and-bleed
- NACE MR0175S

APPLICATIONS & INDUSTRIES

- Oil & gas pipeline including high H₂ S/CO₂ content
- Produced water/brine
- Suction and discharge isolation
- Station isolation
- Meter isolation
- Emergency shutdown (ESD)
- Coke cutting water
- Blowdown
- Offshore riser valves
- Launcher/receiver valves
- Low-and high-temperature service
- Fluid and gas well injection
- Double isolation (twin ball designs)
- Slurry service

FEATURES & BENEFITS

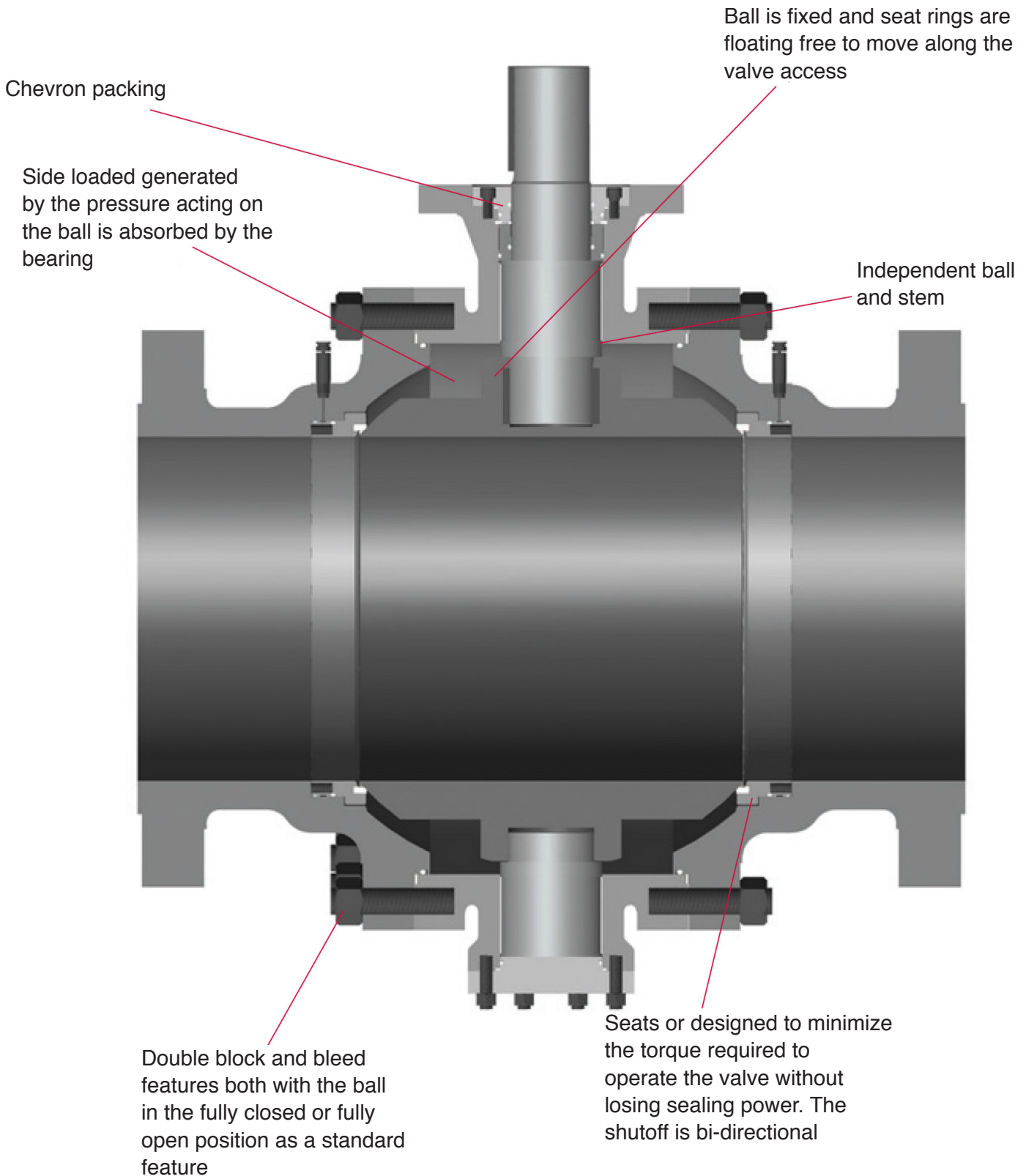

FEATURES

STEM PACKING DESIGN

- The stem is guided by graphite bearing preventing wobbling or radial stem thrust on the packing rings
- Two piece gland bushing
- Stem thrust washer prevents galling, reduces torque, and provides a secondary stem seal
- O-rings provide a secondary stem seal as well

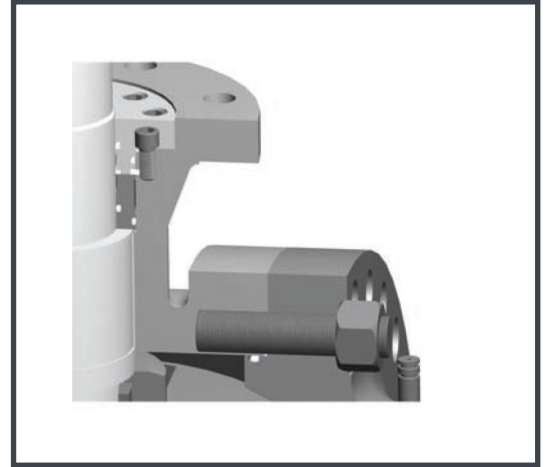

SOFT SEATED VALVES

- The valve is designed for standard service
- Resilient material is inserted into the metal seat holder to provide a soft seated action in addition to the metal-to-metal seating between the ball and seat ring

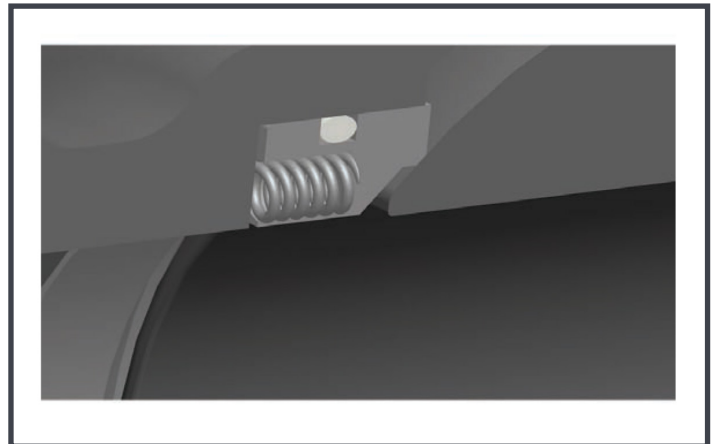
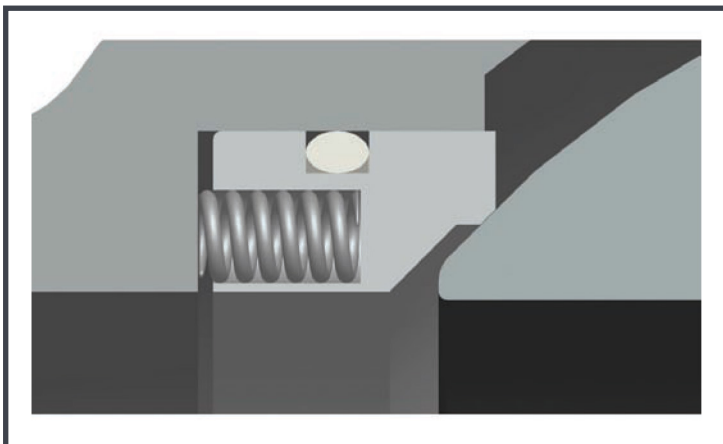
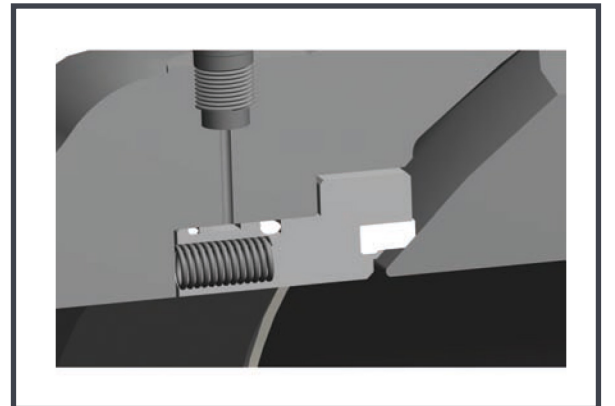

PARTS IDENTIFICATION

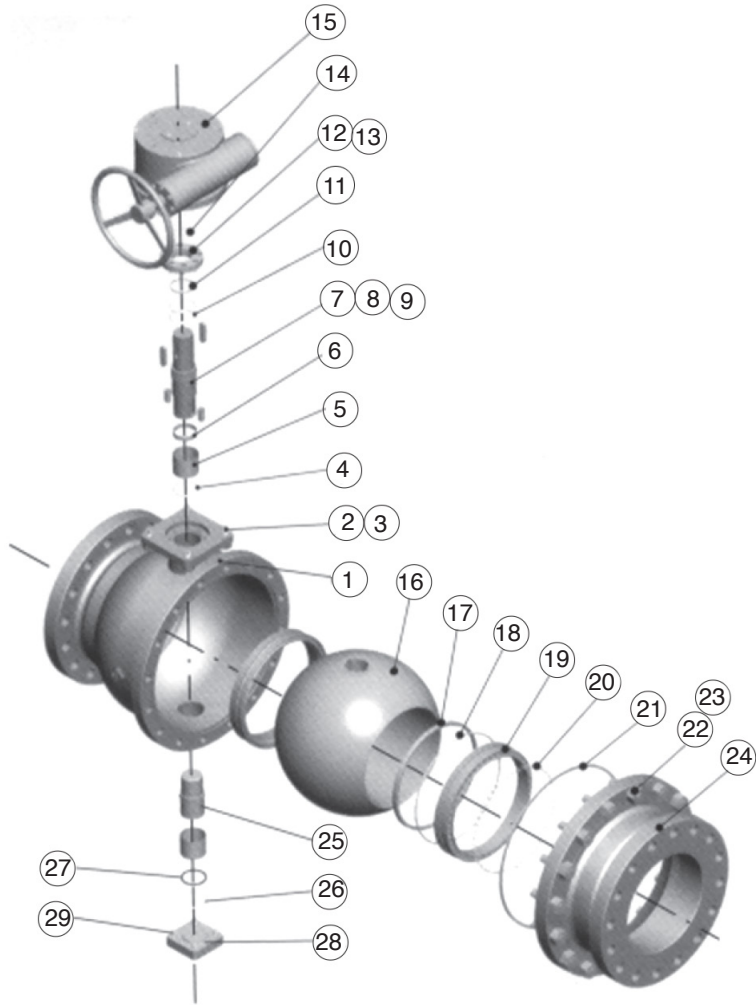

9700 Series Trunnion Valves

PARTS IDENTIFICATION

Part. No.	Name	ASTM A182 F6a	WCB / 304	WCB / 316	CF8	CF8M
1	Body	ASTM A216 WCB	ASTM A216 WCB	ASTM A216 WCB	ASTM A351 CF8	ASTM A351 CF8
2	Nut	ASTM A194 2H	ASTM A194 2H	ASTM A194 2H	ASTM A194 2H	ASTM A194 2H
3	Bolting	ASTM A193 B7	ASTM A193 B7	ASTM A193 B7	ASTM A193 B7	ASTM A193 B7
4	O-ring	Viton	Viton	Viton	Viton	Viton
5	Stem Bearing	Metal Backed PTFE	Metal Backed PTFE	Metal Backed PTFE	Metal Backed PTFE	Metal Backed PTFE
6	Gasket	ASTM A182 F6a	ASTM A182 F304	ASTM A182 F316	ASTM A182 F304	ASTM A182 F316
7	Stem	ASTM A182 F6a	ASTM A182 F304	ASTM A182 F316	ASTM A182 F304	ASTM A182 F316
8	Key	Carbon Steel	Carbon Steel	Carbon Steel	Stainless Steel	Stainless Steel
9	Key	Carbon Steel	Carbon Steel	Carbon Steel	Stainless Steel	Stainless Steel
10	O-ring	Viton	Viton	Viton	Viton	Viton
11	Gasket	PTFE	PTFE	PTFE	PTFE	PTFE
12	Cover	ASTM A105	ASTM A105	ASTM A105	ASTM A182 F304	ASTM A182 F316
13	Capscrew	ASTM A193 B7	ASTM A193 B7	ASTM A193 B7	ASTM A193 B8	ASTM A193 B8M
14	O-ring	Viton	Viton	Viton	Viton	Viton
15	Gear	Carbon Steel	Carbon Steel	Carbon Steel	Carbon Steel	Carbon Steel
16	Ball	ASTM A182 F6a	ASTM A193 B7	ASTM A182 F316	ASTM A182 F304	ASTM A182 F316
17	Seat	Reinforced PTFE	Reinforced PTFE	Reinforced PTFE	Reinforced PTFE	Reinforced PTFE
18	O-ring	Viton	Viton	Viton	Viton	Viton
19	Seat Retainer	ASTM A105	ASTM A105	ASTM A105	ASTM A182 F304	ASTM A182 F316
20	Spring	SS304 or Inconel 750	SS304 or Inconel 750	SS304 or Inconel 750	SS304 or Inconel 750	SS304 or Inconel 750
21	Gasket	Viton, PTFE, or Graphite	Viton, PTFE, or Graphite	Viton, PTFE, or Graphite	Viton, PTFE, or Graphite	Viton, PTFE, or Graphite
22	Body Bolting	ASTM A193 B7	ASTM A193 B7	ASTM A193 B7	ASTM A193 B8	ASTM A193 B8
23	Body Nut	ASTM A194 2H	ASTM A194 2H	ASTM A194 2H	ASTM A194 B8	ASTM A194 8M
24	Closure	ASTM A216 WCB	ASTM A216 WCB	ASTM A216 WCB	ASTM A351 CF8	ASTM A351 CF8M
25	Lower Trunnion	ASTM A182 F6a	ASTM A182 F304	ASTM A182 F316	ASTM A182 F304	ASTM A182 F316
26	O-ring	Viton	Viton	Viton	Viton	Viton
27	Gasket	ASTM A182 F6a	ASTM A182 F304	ASTM A182 F316	ASTM A182 F304	ASTM A182 F316
28	Lower Cover	ASTM A105	ASTM A105	ASTM A105	ASTM A182 F304	ASTM A182 F316
29	Capscrew	ASTM A193 B7	ASTM A193 B7	ASTM A193 B7	ASTM A193 B8	ASTM A193 B8M

Note: The chart above only lists some common composition of steel ball valve parts. We may provide different parts material composition according to the customer's request or the actual valve working condition.

9700 Series Trunnion Valves

DIMENSIONS - ASME CLASS 150 FULL BORE (IN)

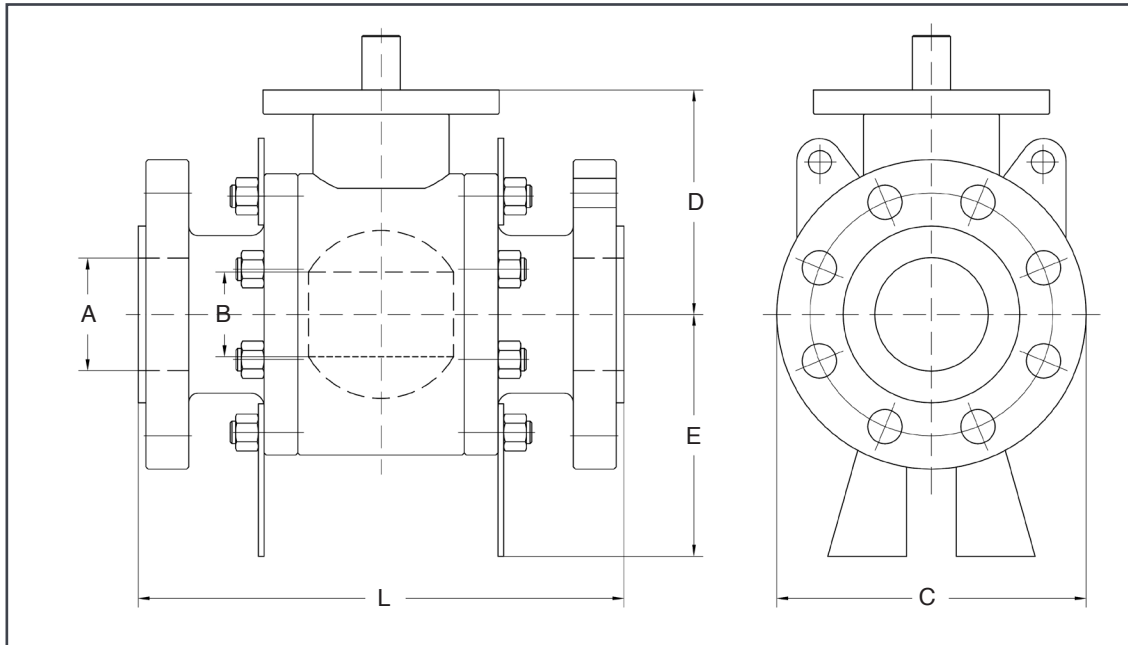

Size (in)	A	B	L-RF	L-WE	C	D	E	Weight
2	1.93	1.93	7	8.50	6.02	4.17	4.02	59
3	2.91	2.91	8	11.13	7.52	6.18	4.96	119
4	3.94	3.94	9	12	9.13	7.80	6.42	196
6	5.91	5.91	15.5	18	12.1	9.72	7.36	352
8	7.91	7.91	18	20.5	15.4	11.0	8.82	557
10	9.92	9.92	21	22	18.3	12.6	10.9	857
12	11.9	11.9	24	25	21.4	13.3	12.1	1230
14	13.2	13.2	27	30	23.9	14.7	13.2	1672
16	15.2	15.2	30	33	26.6	16.1	14.1	2244
18	17.2	17.2	34	36	25.0	17.3	15.4	2673
20	19.2	19.2	36	39	33.4	19.4	17.1	3945
22	21.2	21.2	40	43	36.8	20.8	18.8	5190
24	23.2	23.2	42	45	39.6	23.2	20.6	6818
26	24.9	24.9	45	49	42.0	24.7	22.2	8107
28	26.9	26.9	49	53	44.7	25.4	25.9	9878
30	28.9	28.9	51	55	38.8	27.2	27.7	11473
32	30.7	30.7	54	60	51.2	29.2	29.4	14960
34	32.7	32.7	58	64	53.9	30	30.4	17160
36	34.4	34.4	60	68	56.3	32	31.8	19360
40	38.4	38.4	69	77	62.8	35.4	35.4	27632
42	40.2	40.2	70	82	65.0	37	36.9	31416
48	45.9	45.9	78	94	75.6	43	42.0	48180
56	53.5	53.5	98	98	90.9	51	49.3	70520

9700 Series Trunnion Valves

DIMENSIONS - ASME CLASS 150 REDUCED BORE (IN)

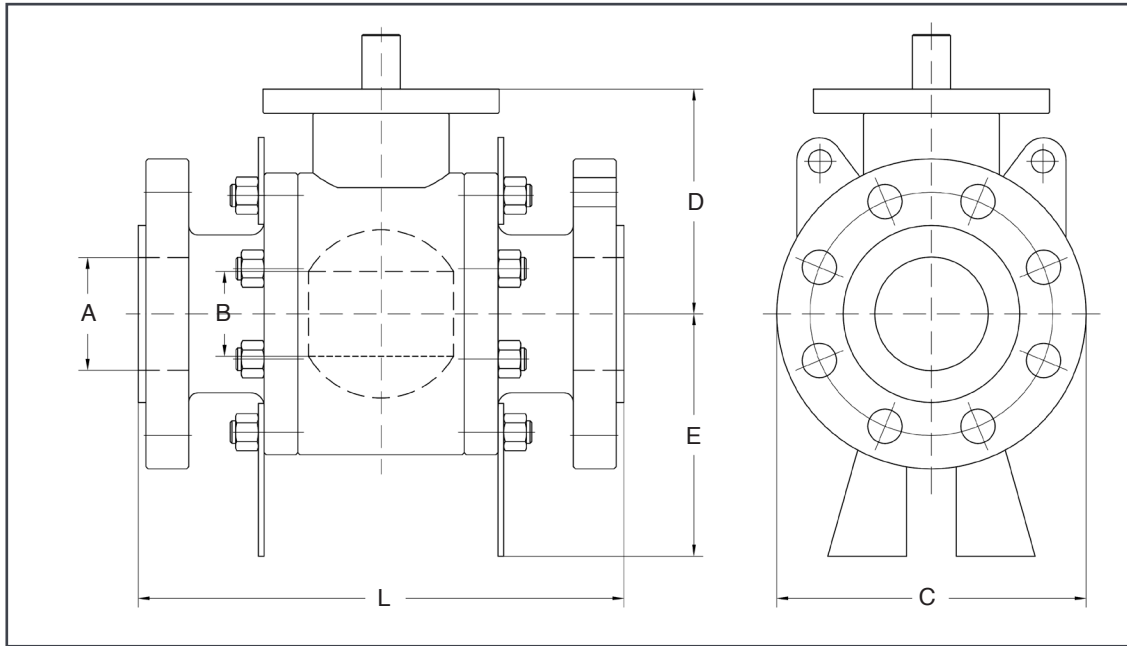

Size (in)	A	B	L-RF	L-WE	C	D	E	Weight
2x1-1/2	1.93	1.50	7	8.5	5.98	3.70	3.86	55
3 x 2	2.91	1.93	11.13	11.1	7.52	4.17	3.94	66
4 x 3	3.94	2.91	12	12	9.02	6.06	5.00	132
6 x 4	5.91	3.94	15.5	18	10.98	7.80	6.42	220
8 x 6	7.91	5.91	18	20.5	13.50	9.92	7.36	407
10 x 8	9.92	7.91	21	22	15.98	11.02	8.74	640
12 x 10	11.93	9.92	24	25	19.02	12.72	11.02	1016
14 x 10	13.15	9.92	27	30	21.06	12.76	10.83	1140
14 x 12	13.15	11.93	27	30	21.06	13.46	11.81	1342
16 x 12	15.16	11.93	30	33	23.43	13.62	11.93	1536
16 x 14	15.16	13.15	30	33	23.43	14.57	13.19	1804
18 x 16	17.17	15.16	34	36	25.00	16.34	13.70	2332
20 x 16	19.17	15.16	36	39	27.56	16.34	13.78	2420
20 x 18	19.17	17.17	36	39	27.56	17.28	15.35	2618
24 x 20	23.19	19.17	42	45	32.09	19.29	17.13	4334
30 x 24	28.94	23.19	51	55	38.78	23.15	20.28	7150
36 x 30	34.41	28.94	60	68	46.06	27.17	27.56	13891

9700 Series Trunnion Valves

DIMENSIONS - ASME CLASS 300 FULL BORE (IN)

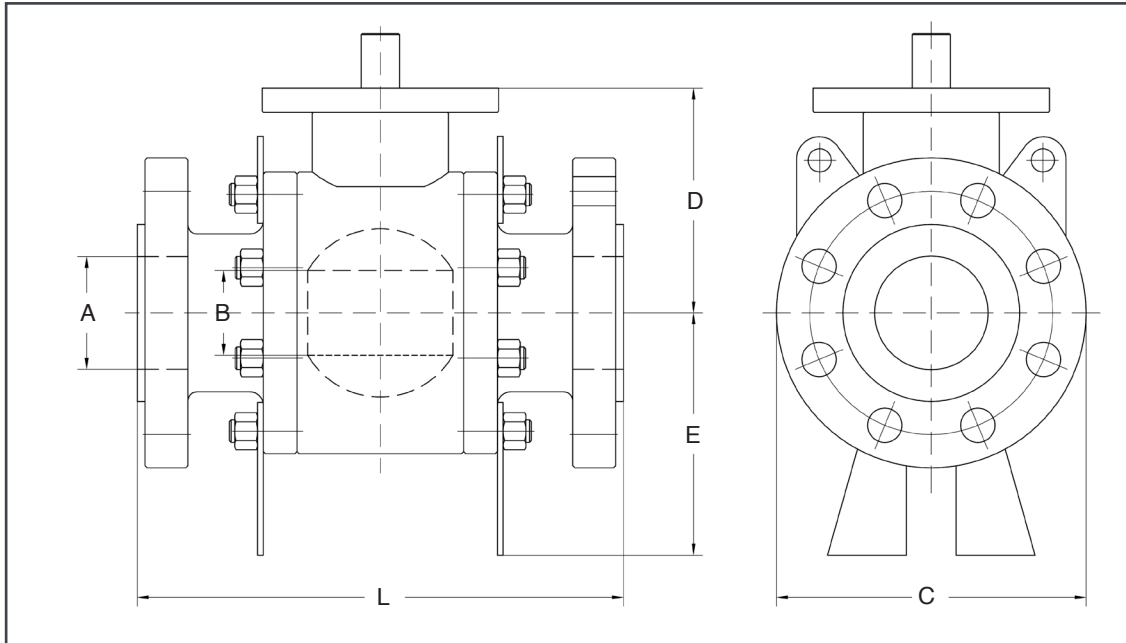

Size (in)	A	B	L-RF	L-WE	C	D	E	Weight
2	1.93	1.93	8.5	8.5	6.5	3.9	3.7	59
3	2.91	2.91	11.1	11.1	8.3	5.9	4.7	121
4	3.94	3.94	12.0	12.0	10	7.9	6.3	202
6	5.91	5.91	15.19	15.19	12.5	9.6	7.9	400
8	7.91	7.91	19.8	19.8	15.2	10.8	9.1	612
10	9.92	9.92	22.4	22.4	18.5	13.0	11.6	1100
12	11.9	11.9	25.5	25.5	21.3	14.0	13.0	1613
14	13.2	13.2	30	30	24.8	15.4	13.6	2264
16	15.2	15.2	33	33	27.3	16.9	15.4	3120
18	17.2	17.2	36	36	30.3	17.9	16.1	3502
20	19.2	19.2	39	39	33.5	19.7	18.3	4829
22	21.2	21.2	43	43	37	20.7	18.9	6134
24	23.2	23.2	45	45	40.2	23.2	21.5	7612
26	24.9	24.9	49	49	42.5	24.8	22.8	10252
28	26.9	26.9	53	53	45.3	25.2	26.2	12694
30	28.9	28.9	55	55	48.6	27.6	28.7	14498
32	30.7	30.7	60	60	52	29.3	30.1	17450
34	32.7	32.7	64	64	54.7	29.9	31.5	19888
36	34.4	34.4	68	68	56.9	31.7	32.5	22205
40	38.4	38.4	77	77	63.8	35.4	36.2	30305
42	40.2	40.2	82	82	66.3	38.1	37.4	35431
48	45.9	45.9	85	85	57.5	43.3	43.3	52932
56	53.5	53.5	108	108	89.6	50.6	50.0	83941

9700 Series Trunnion Valves

DIMENSIONS - ASME CLASS 300 REDUCED BORE (IN)

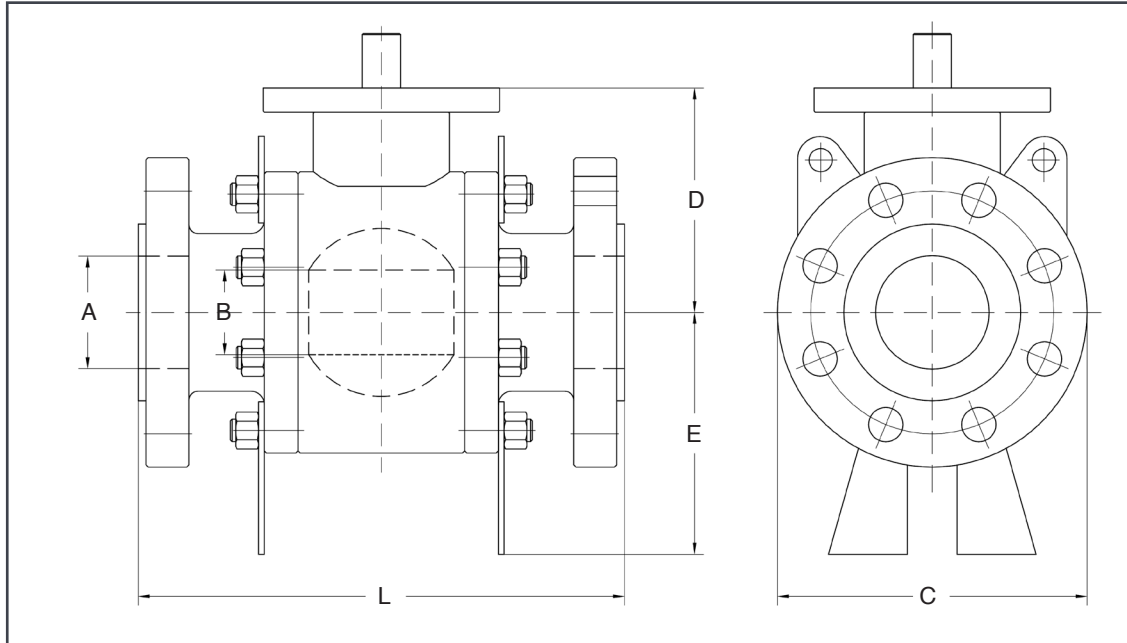

Size (in)	A	B	L-RF	L-WE	C	D	E	Weight
2x1-1/2	1.93	1.50	8.5	8.5	6.5	3.7	3.9	55
3 x 2	2.91	1.93	11.1	11.1	8.3	3.9	3.7	70
4 x 3	3.94	2.91	12.0	12.0	10.0	5.9	4.7	136
6 x 4	5.91	3.94	15.9	15.9	12.5	7.9	6.3	253
8 x 6	7.91	5.91	19.8	19.8	15.0	9.6	7.9	482
10 x 8	9.92	7.91	22.4	22.4	17.5	10.8	9.1	642
12 x 10	11.93	9.92	25.5	25.5	20.5	13	11.6	1307
14 x 10	13.15	9.92	30	30	23	13	11.6	1415
14 x 12	13.15	11.93	30	30	23	14	13	1795
16 x 12	15.16	11.93	33	33	25.6	14	13	2123
16 x 14	15.16	13.15	33	33	25.6	15.4	13.6	2475
18 x 16	17.17	15.16	36	36	28	16.9	15.4	3505
20 x 16	19.17	15.16	39	39	30.5	16.9	15.4	3659
20 x 18	19.17	17.17	39	39	30.5	17.9	16.1	3942
24 x 20	23.19	19.17	45	45	36	19.7	18.3	5854
30 x 24	28.94	23.19	55	55	42.9	23.2	21.5	9565
36 x 30	34.41	28.94	68	68	50	27.6	28.7	18003

9700 Series Trunnion Valves

DIMENSIONS - ASME CLASS 600 FULL BORE (IN)

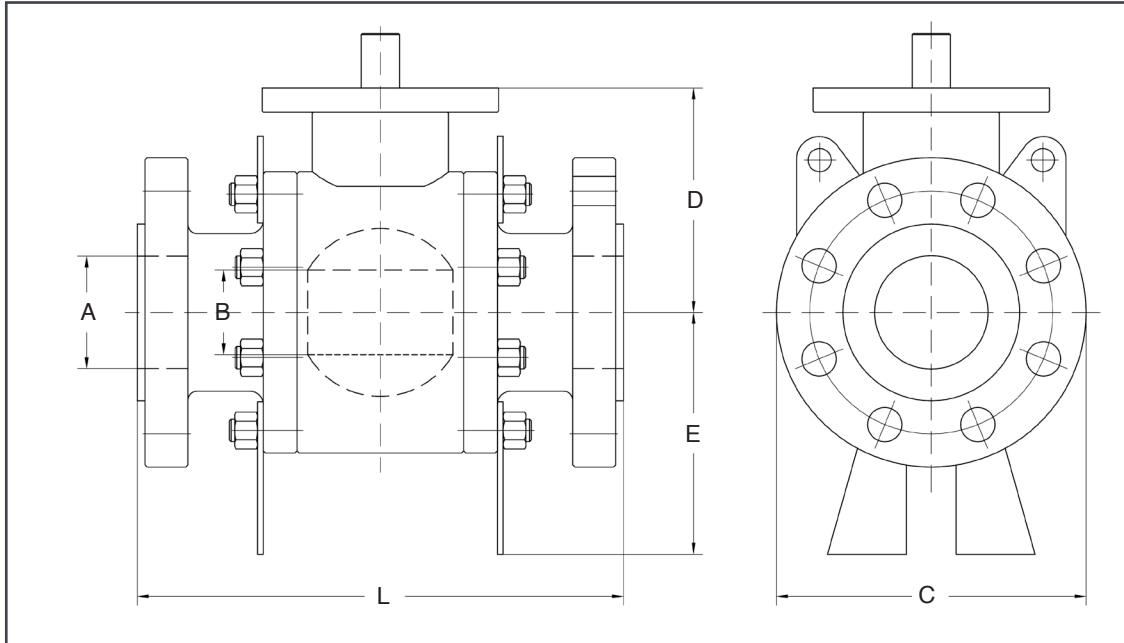

Size (in)	A	B	L-RF	L-RTJ	L-WE	C	D	E	Weight
2	1.93	11.5	11.5	11.63	11.5	6.5	4.0	3.9	68
3	2.91	14	14	14.13	14	8.3	6.5	5.0	136
4	3.94	17	17	17.13	17	10	8.3	6.3	249
6	5.91	22	22	22.13	22	14	9.8	7.9	557
8	7.91	26	26	26.13	26	16.5	11.3	10.0	1037
10	9.92	31	31	31.13	31	20.1	13.0	12.1	1668
12	11.93	33	33	33.13	33	22.6	14.9	13.7	2347
14	13.15	35	35	35.13	35	24.7	15.5	14.2	2383
16	15.16	39	39	39.13	39	27.6	16.9	16.1	3355
18	17.17	43	43	43.13	43	30.5	18.4	16.9	4609
20	19.17	47	47	47.3	47	34.1	19.7	19.4	5804
22	21.18	51	51	51.4	51	37.4	37.4	19.9	8331
24	23.19	55	55	55.4	55	40.5	23.4	22.4	10419
26	24.92	57	57	57.5	57	40.0	24.8	24.3	12423
28	26.93	61	61	61.5	61	46.1	26.2	27.2	14868
30	28.94	66	66	65.5	66	50.8	29.2	31.5	18429
32	30.67	70	70	70.7	70	52.4	29.8	31.7	21424
34	32.68	76	76	76.5	76	55.1	30.8	32.2	24939
36	34.41	82	82	80.6	82	60.9	34.2	37.2	29256
40	38.43	82	82	85.6	85	64.8	36.1	38.6	40337
42	40.16	86	86	85.6	86	70.7	39.2	43.7	46983
48	45.91	96	96	98.6	96	81.5	44.6	49.8	68629
56	53.54	107	107	107	107	94.1	50.8	57.1	104463

9700 Series Trunnion Valves

DIMENSIONS - ASME CLASS 600 REDUCED BORE (IN)

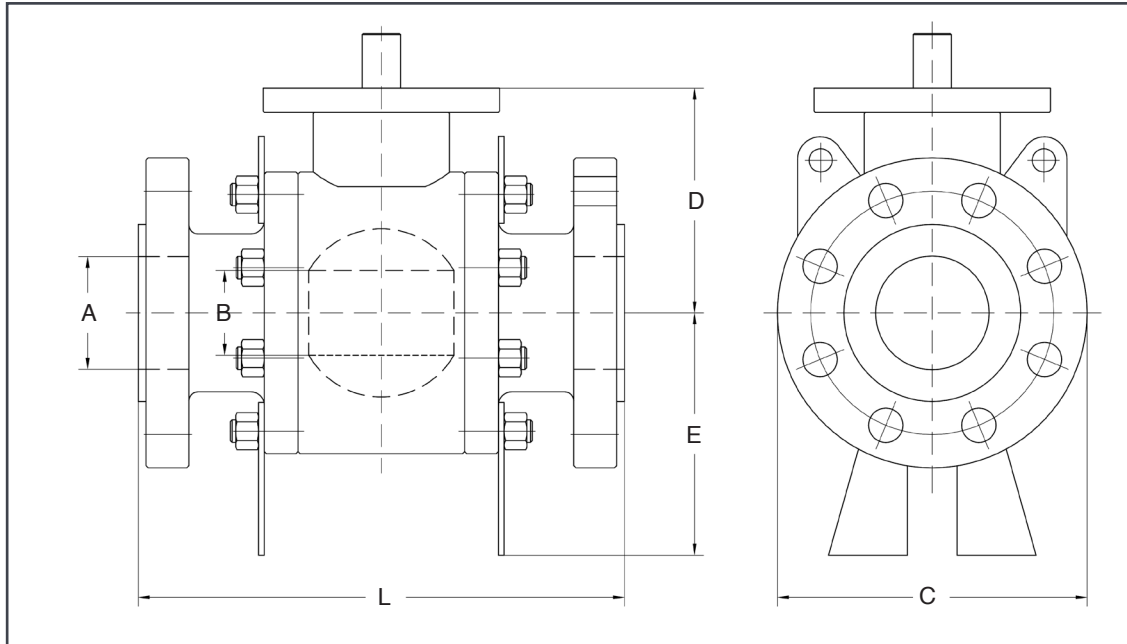

Size (in)	A	B	L-RF	L-RTJ	L-WE	C	D	E	Weight
2x1-1/2	1.93	1.50	11.5	11.63	11.5	3.7	3.7	4.0	68
3 x 2	2.91	1.93	14	14.13	14	3.9	4.0	3.9	86
4 x 3	3.94	2.91	17	17.13	17	5.9	6.5	5.0	172
6 x 4	5.91	3.94	22	22.13	14	7.9	8.3	6.3	330
8 x 6	7.91	5.91	26	26.13	16.5	9.6	9.8	7.9	642
10 x 8	9.92	7.91	31	31.13	20.1	10.8	11.3	10.0	1210
12 x 10	11.93	9.92	33	33.13	22	13	13	12.1	1784
14 x 10	13.15	9.92	35	35.13	23.8	13	13	12.1	2006
14 x 12	13.15	11.93	35	35.13	23.8	14	14.9	13.7	2519
16 x 12	15.16	11.93	39	39.13	27	14	14.9	13.7	2966
16 x 14	15.16	13.15	40	39.13	24.7	15.4	15.5	14.2	2383
18 x 16	17.17	15.16	43	43.13	29.3	16.9	16.9	16.1	3696
20 x 16	19.17	15.16	47	47.25	32.1	16.9	16.9	16.1	4587
20 x 18	19.17	17.17	47	47.25	32.1	17.9	18.4	16.9	5225
24 x 20	23.19	19.17	55	55.38	37	19.7	19.7	19.4	7146
30 x 24	28.94	23.19	66	65.5	44.5	23.2	23.4	22.4	12690
36 x 30	34.41	28.94	82	82.63	51.8	27.6	27.9	29.6	22827

9700 Series Trunnion Valves

DIMENSIONS - ASME CLASS 900 FULL BORE (IN)

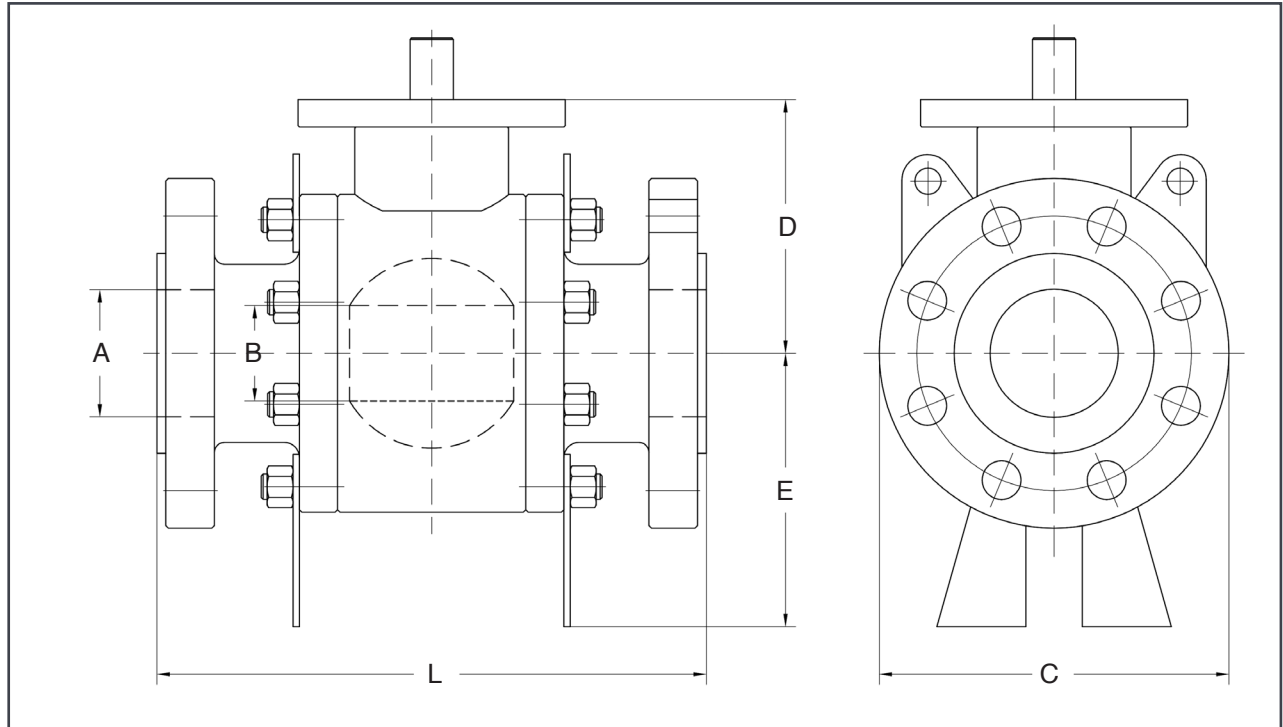

Size (in)	A	B	L-RF	L-RTJ	L-WE	C	D	E	Weight
2	1.93	1.93	14.5	14.61	14.5	8.50	4.09	4.06	106
3	2.91	2.91	15	15.12	15	9.49	6.42	5.20	121
4	3.94	3.94	18	18.11	18	11.5	8.31	6.65	319
6	5.91	5.91	24	24.13	24	15	10.20	8.39	792
8	7.91	7.91	29	29.13	29	18.5	11.69	10.39	1276
10	9.92	9.92	33	33.11	33	21.5	13.46	13.11	2222
12	11.9	11.9	38	38.11	38	24	15.12	14.92	3322
14	12.7	12.7	40.5	40.87	40.5	25.2	15.67	14.49	3190
16	14.7	14.7	44.5	44.88	44.5	27.95	17.17	17.20	4730
18	16.7	16.7	48	48.50	48	31.5	19.06	19.47	6204
20	18.5	18.5	52	52.84	52	35.0	20.94	19.80	9240
24	22.4	22.4	61	61.73	61	41.7	24.29	24.92	14960
28	26.2	26.2	69	69.88	69	48.58	26.54	27.80	21780
30	28.0	28.0	74	74.88	74	51.18	28.46	30.59	26796
32	29.9	29.9	80	80.87	80	53.43	30.87	31.85	26004
34	31.8	31.8	85	86.14	85	57.8	31.77	33.54	37840
36	33.7	33.7	90	91.14	90	60.3	33.39	35.35	41580

9700 Series Trunnion Valves

DIMENSIONS - ASME CLASS 900 REDUCED BORE (IN)

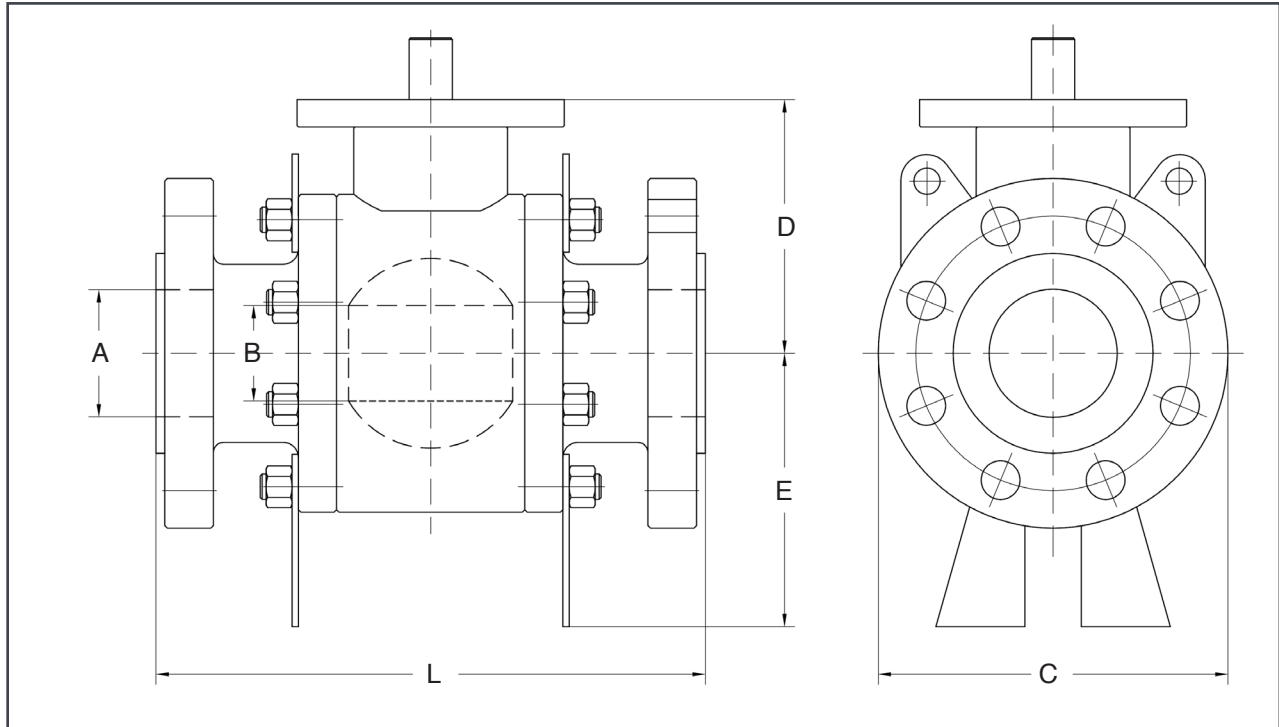

Size (in)	A	B	L-RF	L-RTJ	L-WE	C	D	E	Weight
2x1-1/2	1.93	1.50	14.5	14.6	14.5	8.50	4.06	4.02	90
3 x 2	2.91	1.93	15	15.1	15	9.49	4.06	4.02	114
4 x 3	3.94	2.91	18	18.1	18	11.5	6.54	5.00	209
6 x 4	5.91	3.94	24	24.1	24	15.0	8.19	6.42	451
8 x 6	7.91	5.91	29	29.1	29	18.5	10.4	8.39	968
10 x 8	9.92	7.91	33	33.1	33	21.5	11.8	10.6	1518
12 x 10	11.9	9.92	38	38.1	38	24.0	13.7	12.9	2541
14 x 10	12.7	9.92	40.5	40.9	40.5	25.2	13.7	12.9	2728
14 x 12	12.7	11.93	40.5	40.9	40.5	25.2	15.8	15.0	3597
16 x 12	14.7	11.93	44.5	44.9	44.5	27.8	15.8	15.0	3806
16 x 14	14.7	12.68	44.5	44.9	44.5	27.6	15.8	17.3	3740
18 x 16	16.7	14.69	48	48.5	48	31.1	17.3	17.4	5368
20 x 16	18.5	14.69	52	52.5	52	31.1	17.3	17.4	6325
20 x 18	18.5	16.65	52	52.5	52	33.7	18.9	19.1	7150
24 x 20	22.4	18.54	61	61.7	61	40.9	21.0	19.7	11880
30 x 24	28.0	22.44	74	74.9	74	48.4	23.9	24.9	19140
36 x 30	33.7	28.03	90	90.0	90	57.5	28.7	30.9	33770

9700 Series Trunnion Valves

DIMENSIONS - ASME CLASS 1500 FULL BORE (IN)

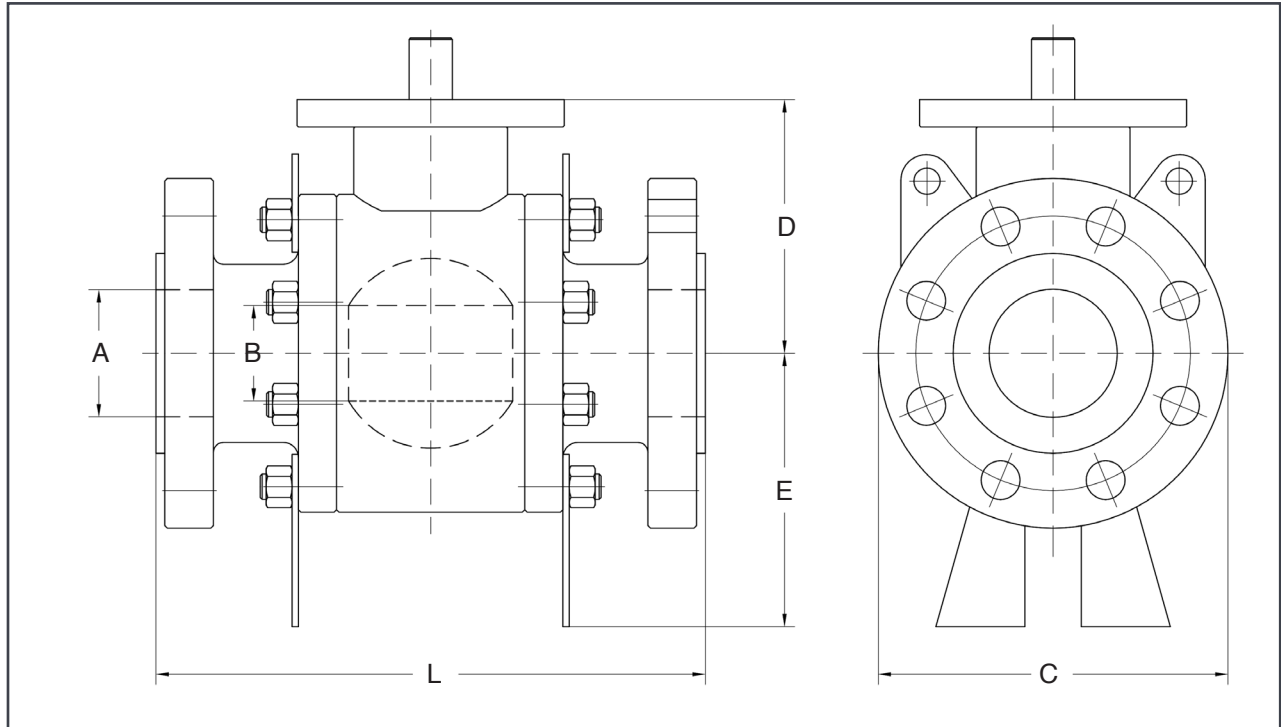

Size (in)	A	B	L-RF	L-RTJ	L-WE	C	D	E	Weight
2	1.93	1.93	14.5	14.6	14.5	8.50	4.17	4.02	110
3	2.91	2.91	18.5	18.6	18.5	10.5	6.57	5.04	213
4	3.94	3.94	21.5	21.6	21.5	12.2	7.05	6.69	436
6	5.67	5.67	27.8	278.0	27.8	15.5	10.2	9.17	1056
8	7.56	7.56	32.8	33.1	32.8	19.0	12.0	11.4	1804
10	9.41	9.41	39.0	39.4	39.0	23.0	14.3	13.9	3300
12	11.3	11.3	44.5	45.1	44.5	27.9	16.4	16.7	4950
14	12.4	12.4	49.5	50.2	49.5	30.1	17.2	16.8	6270
16	14.2	14.2	54.5	55.4	54.5	33.4	18.7	19.4	8954
18	15.9	15.9	58.2	59.0	60.5	38.6	22.1	23.9	13629
20	17.9	17.9	65.5	66.4	65.5	40.0	24.3	25.4	19965
24	20.9	20.9	70.2	71.3	80.4	50.9	27.5	28.5	31416

9700 Series Trunnion Valves

DIMENSIONS - ASME CLASS 2500 FULL BORE (IN)

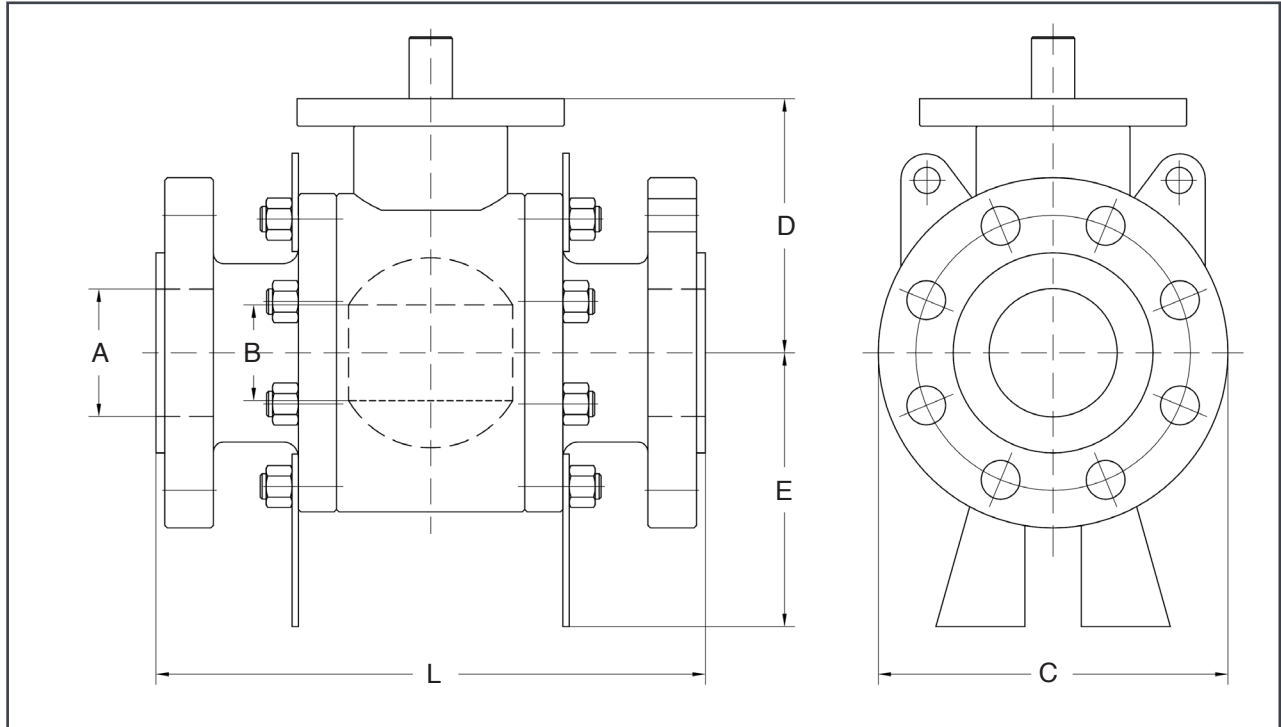

Size (in)	A	B	L-RF	L-RTJ	L-WE	C	D	E	Weight
2	1.65	1.65	17.76	17.9	17.8	9.25	472	5.00	194
3	2.44	2.44	22.76	23.0	22.8	12.0	6.97	7.80	411
4	3.43	3.43	26.50	26.9	26.5	14.0	8.94	9.17	836
6	5.16	5.16	35.98	36.5	36.0	19.0	10.4	9.92	1694
8	7.05	7.05	40.24	40.9	40.2	24.4	15.1	13.4	2985
10	8.78	8.78	50.0	50.9	50.0	29.3	17.8	16.6	4620
12	10.43	10.43	56.0	56.9	56.0	34.3	20.5	19.0	7062

9700 Series Trunnion Valves

HOW TO ORDER

Series	Body	Ball & Stem	Port	Stem Packing	Seat	End Connection
97	0 LF2	3 316	F Full	T PTFE	C Carbon PEEK	B Butt Weld
	2 WCB	4 Alloy 20		G Graphoil	K Kel-F	S Socket Weld
	3 316	5 Monel			P PEEK	F Flanged
	4 Alloy 20	7 Hastelloy			T PTFE	FF Flat Face
	5 Monel	A 304			R Reinforced	F1 ANSI 150
	7 Hastelloy				D Devon/Delrin	F3 ANSI 300
					N Nylon	F6 ANSI 600
					F15 ANSI 1500	
					F25 ANSI 2500	

J Flow Controls®
 4665 Interstate Drive
 Cincinnati, OH 45246
 513-330-6354
jflowcontrols.com

While the information and specifications contained in this literature are believed to be accurate, they are supplied for informative purposes only and should not be considered certified or a guarantee of satisfactory results. Nothing contained herein is to be construed as a warranty or guarantee, express or implied, regarding any matter with respect to this product. Because J Flow Controls® is continually improving and upgrading its product design, the specifications, dimensions and information contained herein are subject to change without notice.