



DESCRIPTION

- 3 - Piece High Performance Ball Valve
- Full Port
- 1/4" - 2"
- 7500 PSI (WOG)

600 Series

CERTIFICATIONS

- Valve Test: API 598
- Anti-Static: API 608
- Steel Casting: MSS SP-55
- Valve Marking: MSS SP-25
- Valve Design: ASME B16.34
- Face to Face: ASME B16.10
- Class (Pressure Rating): Class 2500 / 3000
- Material Certification: EN10204-3.1 MTR
- Sulfide Stress Cracking: NACE MR-01-75
- Quality Assurance: ISO 9001:2008 Certified
- End Connection: ASME B1.20.1, ASME B16.11, ASME B16.25

OPTIONS

- Fire-Safe Design
- Spring Return (Dead-Man) Handle
- Oval Handle
- Locking Device
- Automation Application
- Cryogenic Type
- PTFE / PFA Coating (40-70 um)

- DELRIN
- PEEK
- DEVLON
- Carbon PEEK

FEATURES AND BENEFITS

- Body and End Caps Are Machined by Bar Stock
- In-Line Repairable Design
- With 4 Holes for Mounting Bracket
- Adjustable Stem Packing
- Standard in Stainless Steel
- Blow-Out Proof Stem Design
- 100% Air Tested Under Water at 80-100 psi
- Working Pressure of 7500 (1/4" - 1") / 6000 (1-1/2" - 2") psi
- Temperature Range from -320°F to 625°F
- End Connection: Butt Weld, Socket Weld, and Threaded

PRESSURE/TEMPERATURE CHART

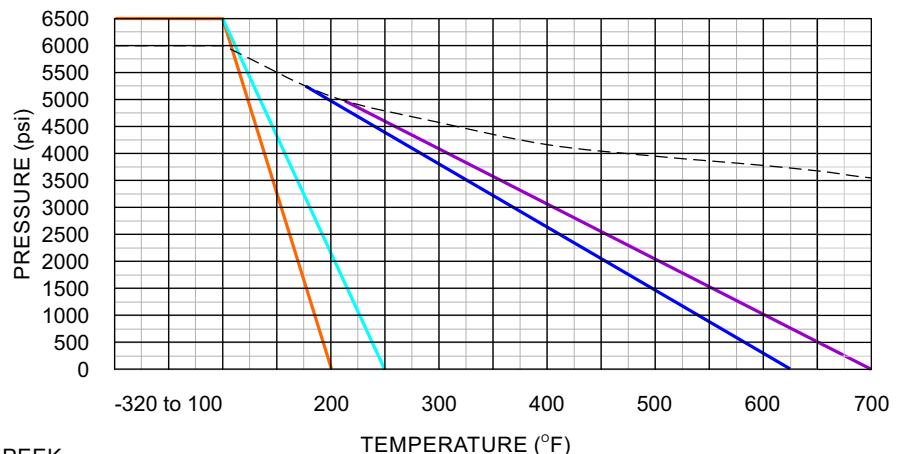

While the information and specifications contained in this literature are believed to be accurate, they are supplied for informative purposes only and should not be considered certified or a guarantee of satisfactory results. Nothing contained herein is to be construed as a warranty or guarantee, express or implied, regarding any matter with respect to this product. Because J Flow Controls is continually improving and upgrading its product design, the specifications, dimensions and information contained herein are subject to change without notice.

600 Series Valves

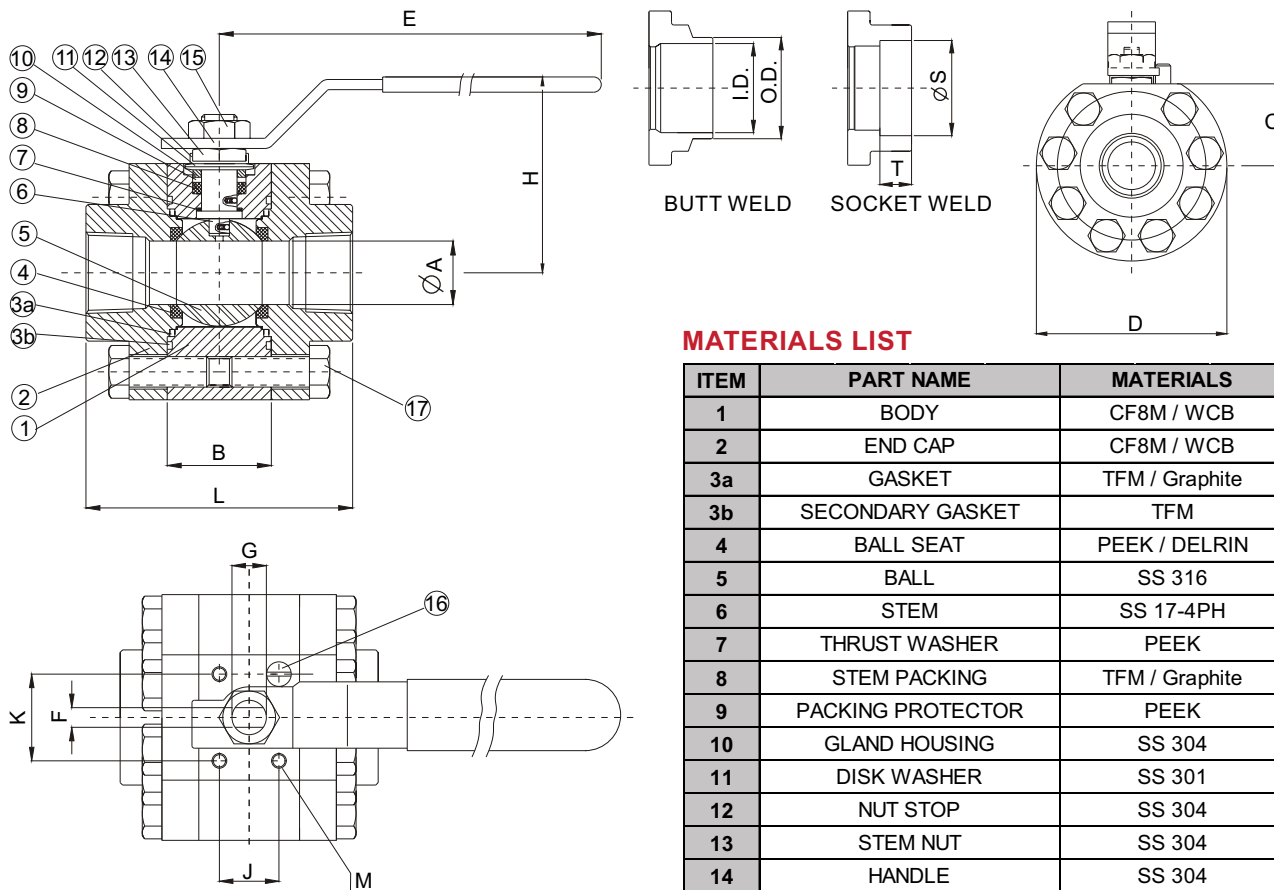

MATERIALS LIST

ITEM	PART NAME	MATERIALS
1	BODY	CF8M / WCB
2	END CAP	CF8M / WCB
3a	GASKET	TFM / Graphite
3b	SECONDARY GASKET	TFM
4	BALL SEAT	PEEK / DELRIN
5	BALL	SS 316
6	STEM	SS 17-4PH
7	THRUST WASHER	PEEK
8	STEM PACKING	TFM / Graphite
9	PACKING PROTECTOR	PEEK
10	GLAND HOUSING	SS 304
11	DISK WASHER	SS 301
12	NUT STOP	SS 304
13	STEM NUT	SS 304
14	HANDLE	SS 304
15	HANDLE NUT	SS 304
16	STOP PIN	SS 304
17	BODY BOLTS	B8 / B7

DIMENSIONS (in)

SIZE	A	B	C	D	E	F	G	H	L	OPTION			SW		BW (80#)	
										J	K	M	S	T	OD	ID
1/4"	0.43	0.81	1.06	2.91	6.89	0.25	3/8	1.77	2.60	-	-	M5	0.56	0.44	0.54	0.31
3/8"	0.49	0.81	1.06	2.91	6.89	0.25	3/8	1.77	2.60	-	-	M5	0.69	0.44	0.68	0.40
1/2"	0.59	1.01	1.26	3.11	6.89	0.25	3/8	1.89	2.80	0.51	1.06	M5	0.86	0.50	0.84	0.54
3/4"	0.79	1.26	1.50	3.70	7.87	0.31	M12	2.48	3.62	0.75	1.18	M5	1.07	0.51	1.05	0.74
1"	0.98	1.61	1.69	3.90	9.84	0.38	M14	2.72	4.17	0.91	1.65	M5	1.33	0.51	1.31	0.96
1-1/2"	1.50	2.20	2.17	5.71	11.42	0.38	M18	3.23	5.51	1.57	2.28	M6	1.91	0.63	1.91	1.50
2"	1.97	2.83	2.99	7.44	13.78	0.47	M20	5.71	6.50	1.97	3.54	M10	2.41	0.63	2.38	1.93

HOW TO ORDER

Example: 075-633FPGGPKFPTNANA

VALVE SIZE	PRODUCT SERIES	BODY MATERIAL	BALL/STEM MATERIAL	PORT	PACKING / BODY SEAL MATERIAL
025 1/4"	100 1"	2 WCB	3 CF8M	FP Full Port	GG Graphite
038 3/8"	150 1-1/2"	3 CF8M			
050 1/2"	200 2"				
075 3/4"					

* Consult factory for delivery.

SEAT MATERIAL	END CONNECTIONS	MATERIAL OPTIONS	DESIGN OPTIONS
DE DELRIN	SCW Socket Weld	NA Standard (Graphite)	NA Standard
DV DEVLON	FPT Female NPT		
PK *PEEK	W80 Butt Weld sch 80		
PC *Carbon PEEK	FMT Female Metric THD		